

# GB2

## 2-WAY HIGH PRESSURE BALL VALVES

### CARBON STEEL

- Type: ball valve GB 2 way
- Body: round
- Ball seats: from DN32 up to DN50
- Operating pressure: 350 Bar  
depending on valve size and seal materials selected
- Temp range: -20°C to +100°C  
depending on seal material selected

### STAINLESS STEEL

- Type: ball valve GB 2 way
- Body: round
- Ball seats: from DN32 up to DN50
- Operating pressure: 350 Bar  
depending on valve size and seal materials selected
- Temp range: -30°C to +100°C  
depending on seal material selected

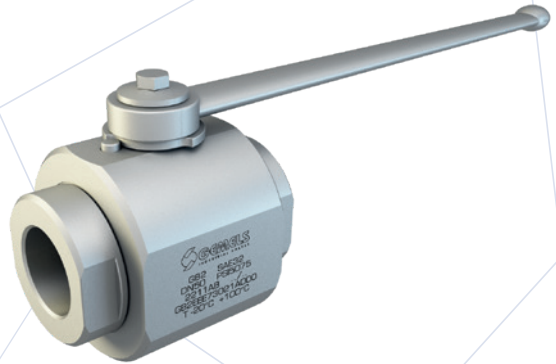

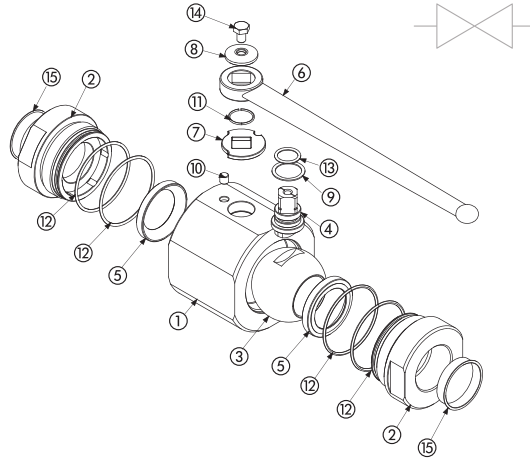

CARBON STEEL			
POS	DESCRIPTION	MATERIAL	Q.TY
1	Body	1,0570	1
2	Adapter	1,0570	2
3	Ball	1,0737	1
4	Stem	1,0737	1
5	Ball seat	POM	2
6	Handle	1,0116	1
7	Washer	1,0116	1
8	Washer	1,0737	1
9	Stem ring	POM	1
10	Spine	1,0737	1
11	Seeger	1,4301	1
12	Adapter o-ring	NBR	4
13	Stem o-ring	NBR	1
14	Screw	ISO4017 8.8	1
15	Caps	PVC	2

CARBON STEEL												
GB2		G1½		DN32		2	2	1	1	A	B	
TYPE AND WAY OF VALVE	GAS DIN/ ISO 228 BSP	NPT ANSI/ ASME B1.20.1	SAE J1926-1	DIN 2353 HEAVY SERIES	DIN 2353 LIGHT SERIES	NOMINAL DIMENSION	BODY MATERIAL	ADAPTER MATERIAL	STEM MATERIAL	BALL MATERIAL	BALL SEAT MATERIAL	ADAPTER AND STEM SEAL MATERIAL
GB2 2-way	G 1 ¼	N 1 ¼	SAE20	38S	35L	DN32	2 1,0570	2 1,0570	1 1,0737	1 1,0737	A POM	B NBR
	G 1 ½	N 1 ½	SAE24		42L	DN40			4 1,4404*	4 1,4404*	D PEEK*	E FKM*
	G 2R	N 2R	SAE32			DN50					G PA612*	F EPDM*
	G 2	N 2									K GEMPTFE*	L MVQ*
											C PTFE*	

STAINLESS STEEL			
POS	DESCRIPTION	MATERIAL	Q.TY
1	Body	1,4044	1
2	Adapter	1,4044	2
3	Ball	1,4044	1
4	Stem	1,4301	1
5	Ball seat	POM	2
6	Handle	1,4031	1
7	Washer	1,4031	1
8	Washer	1,4031	1
9	Stem ring	POM	1
10	Spine	1,4301	1
11	Seeger	1,4301	1
12	Adapter o-ring	NBR	4
13	Stem o-ring	NBR	1
14	Screw	ISO4017 A2	1
15	Caps	PVC	2

STAINLESS STEEL												
GB2		G1½		DN32		4	4	4	4	A	B	
TYPE AND WAY OF VALVE	GAS DIN/ ISO 228 BSP	NPT ANSI/ ASME B1.20.1	SAE J1926-1	DIN 2353 HEAVY SERIES	DIN 2353 LIGHT SERIES	NOMINAL DIMENSION	BODY MATERIAL	ADAPTER MATERIAL	STEM MATERIAL	BALL MATERIAL	BALL SEAT MATERIAL	ADAPTER AND STEM SEAL MATERIAL
GB2 2-way	G 1 ¼	N 1 ¼	SAE20	38S	35L	DN32	4 1,4404	4 1,4404	4 1,4404	4 1,4404	A POM	B NBR
	G 1 ½	N 1 ½	SAE24		42L	DN40					D PEEK*	E FKM*
	G 2R	N 2R	SAE32			DN50					G PA612*	F EPDM*
	G 2	N 2									K GEMPTFE*	L MVQ*
											C PTFE*	

\*On request:

- Reduced bore
- Special threads

- Pressure class up to PN35 MPa
- Pneumatic and electrical actuator

- Security block
- Locking device

For further special requests please consult our technical/commercial service

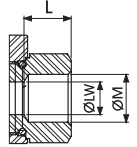
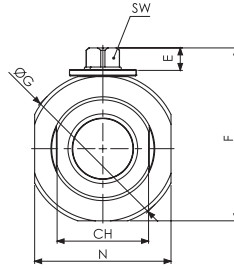
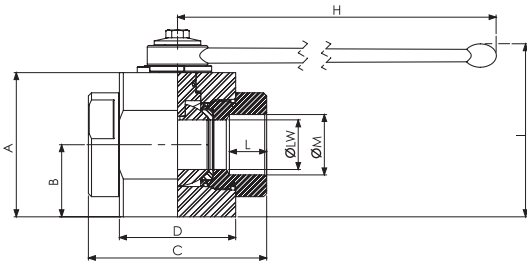

## GB2 DIN/ISO 228 BSP

Standard

TYPE	PN	DN	A	B	C	D	E	F	ØG	H	I	L	ØM	N	CH	SW	ØLW	KG	CARBON STEEL	STAINLESS STEEL
																			ITEM CODE	ITEM CODE
GB2 G 1 1/4	35 MPa	32	93	46,5	115	75	13,5	111,5	98	300	120,5	24	G 1 1/4	88	60	17	32	6,975	GB2GGT63021A000	GB2GGT63044A000
GB2 G 1 1/2	35 MPa	40	107	53,5	131	85	13,5	125,5	113	300	134,5	25	G 1 1/2	102	75	17	40	7,393	GB2GGT73021A000	GB2GGT73044A000
GB2 G 2R	35 MPa	40	107	53,5	131	85	13,5	125,5	113	300	134,5	25	G 2	102	75	17	40	6,975	GB2GGR83021A000	GB2GGR83044A000
GB2 G 2	35 MPa	50	114	57	140	98	13,5	132,5	123	300	141,5	27	G 2	118	85	17	50	9,046	GB2GGT83021A000	GB2GGT83044A000

## GB2 ANSI/ASME B1.20.1 NPT

Standard

TYPE	PN	DN	A	B	C	D	E	F	ØG	H	I	L	ØM	N	CH	SW	ØLW	KG	CARBON STEEL	STAINLESS STEEL
																			ITEM CODE	ITEM CODE
GB2 N 1 1/4	35 MPa	32	93	46,5	115	75	13,5	111,5	98	300	120,5	24	N 1 1/4	88	60	17	32	6,975	GB2NNT63021A000	GB2NNT63044A000
GB2 N 1 1/2	35 MPa	40	107	53,5	131	85	13,5	125,5	113	300	134,5	25	N 1 1/2	102	75	17	40	7,393	GB2NNT73021A000	GB2NNT73044A000
GB2 N 2R	35 MPa	40	107	53,5	131	85	13,5	125,5	113	300	134,5	25	N 2	102	75	17	40	6,975	GB2NNR83021A000	GB2NNR83044A000
GB2 N 2	35 MPa	50	114	57	140	98	13,5	132,5	123	300	141,5	27	N 2	118	85	17	50	9,046	GB2NNT83021A000	GB2NNT83044A000

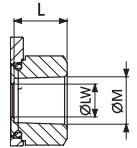

## GB2 SAE J1926-1

Standard

TYPE	PN	DN	A	B	C	D	E	F	ØG	H	I	L	ØM	N	CH	SW	ØLW	KG	CARBON STEEL	STAINLESS STEEL
																			ITEM CODE	ITEM CODE
GB2 SAE20	35 MPa	32	93	46,5	115	75	13,5	111,5	98	300	120,5	24	1 5/8 UNF	88	60	17	32	6,975	GB2EEE53021A000	GB2EEE53044A000
GB2 SAE24	35 MPa	40	107	53,5	131	85	13,5	125,5	113	300	134,5	25	1 7/8 UNF	102	75	17	40	7,393	GB2EEE63021A000	GB2EEE63044A000
GB2 SAE32	35 MPa	50	114	57	140	98	13,5	132,5	123	300	141,5	27	2 1/2 UNF	118	85	17	50	9,046	GB2EEE73021A000	GB2EEE73044A000

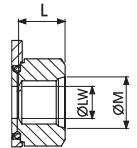

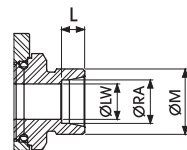
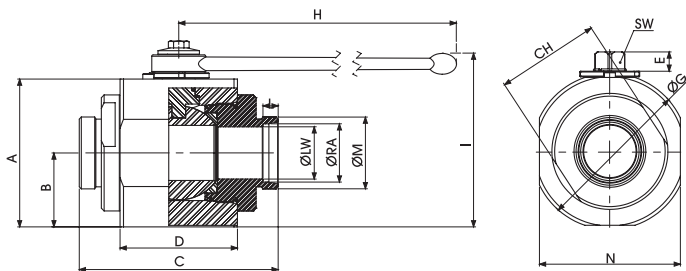

### GB2 DIN 2353 HEAVY SERIES

Standard

TYPE	PN	DN	A	B	C	D	E	F	ØG	H	I	L	ØM	N	CH	SW	ØLW	ØRA	KG	CARBON STEEL	STAINLESS STEEL
																				ITEM CODE	ITEM CODE
GB2 38S	35 MPa	32	93	46,5	146	75	13,5	111,5	98	300	120,5	16	M52x2	88	60	17	32	38,3	5,229	GB2DDS93021A000	GB2DDS93044A000

### GB2 DIN 2353 LIGHT SERIES

Standard

TYPE	PN	DN	A	B	C	D	E	F	ØG	H	I	L	ØM	N	CH	SW	ØLW	ØRA	KG	CARBON STEEL	STAINLESS STEEL
																				ITEM CODE	ITEM CODE
GB2 35L	35 MPa	32	93	46,5	135	75	13,5	111,5	98	300	120,5	10,5	M45x2	88	60	17	32	35,3	5,079	GB2DDLA3021A000	GB2DDLA3044A000
GB2 42L	35 MPa	40	107	53,5	144	85	13,5	125,5	113	300	134,5	11	M52x2	102	75	17	40	42,3	7,144	GB2DDL3021A000	GB2DLB3044A000

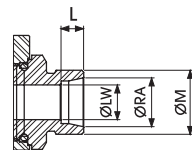

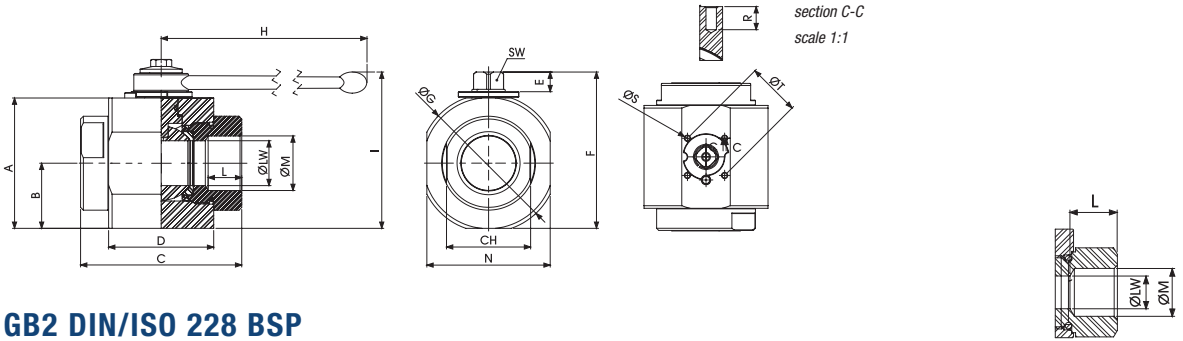

## GB2 DIN/ISO 228 BSP

Fixing holes DIN/ISO5211

TYPE	PN	DN	A	B	C	D	E	F	ØG	I	L	ØM	N	CH	R	ØS	ØT	SW	ØLW	KG	CARBON STEEL	STAINLESS STEEL
																					ITEM CODE	ITEM CODE
GB2 G 1 1/4	35 MPa	32	93	46,5	115	75	13,5	111,5	98	120,5	24	G 1 1/4	88	60	11	M6	50	17	32	6,975	GB2GGT63021AF50	GB2GGT63044AF50
GB2 G 1 1/2	35 MPa	40	107	53,5	131	85	13,5	125,5	113	134,5	25	G 1 1/2	102	75	11	M6	50	17	40	7,393	GB2GGT73021AF50	GB2GGT73044AF50
GB2 G 2R	35 MPa	40	107	53,5	131	85	13,5	125,5	113	134,5	25	G 2	102	75	11	M6	50	17	40	6,975	GB2GGR83021AF50	GB2GGR83044AF50
GB2 G 2	35 MPa	50	114	57	140	98	13,5	132,5	123	141,5	27	G 2	118	85	11	M6	50	17	50	9,046	GB2GGT83021AF50	GB2GGT83044AF50

## GB2 ANSI/ASME B1.20.1 NPT

Fixing holes DIN/ISO5211

TYPE	PN	DN	A	B	C	D	E	F	ØG	I	L	ØM	N	CH	R	ØS	ØT	SW	ØLW	KG	CARBON STEEL	STAINLESS STEEL
																					ITEM CODE	ITEM CODE
GB2 N 1 1/4	35 MPa	32	93	46,5	115	75	13,5	111,5	98	120,5	24	N 1 1/4	88	60	11	M6	50	17	32	6,975	GB2NNT63021AF50	GB2NNT63044AF50
GB2 N 1 1/2	35 MPa	40	107	53,5	131	85	13,5	125,5	113	134,5	25	N 1 1/2	102	75	11	M6	50	17	40	7,393	GB2NNT73021AF50	GB2NNT73044AF50
GB2 N 2R	35 MPa	40	107	53,5	131	85	13,5	125,5	113	134,5	25	N 2	102	75	11	M6	50	17	40	6,975	GB2NNR83021AF50	GB2NNR83044AF50
GB2 N 2	35 MPa	50	114	57	140	98	13,5	132,5	123	141,5	27	N 2	118	85	11	M6	50	17	50	9,046	GB2NNT83021AF50	GB2NNT83044AF50

## GB2 SAE J1926-1

Fixing holes DIN/ISO5211

TYPE	PN	DN	A	B	C	D	E	F	ØG	I	L	ØM	N	CH	R	ØS	ØT	SW	ØLW	KG	CARBON STEEL	STAINLESS STEEL
																					ITEM CODE	ITEM CODE
GB2 SAE20	35 MPa	32	93	46,5	115	75	13,5	111,5	98	120,5	24	1 5/8 UNF	88	60	11	M6	50	17	32	6,975	GB2EEE53021AF50	GB2EEE53044AF50
GB2 SAE24	35 MPa	40	107	53,5	131	85	13,5	125,5	113	134,5	25	1 7/8 UNF	102	75	11	M6	50	17	40	7,393	GB2EEE63021AF50	GB2EEE63044AF50
GB2 SAE32	35 MPa	50	114	57	140	98	13,5	132,5	123	300	141,5	2 1/2 UNF	118	85	11	M6	50	17	50	9,046	GB2EEE73021AF50	GB2EEE73044AF50

