

EuroSnodi

S.R.L.



Agricultural Division



**Catalogo
Tecnico**

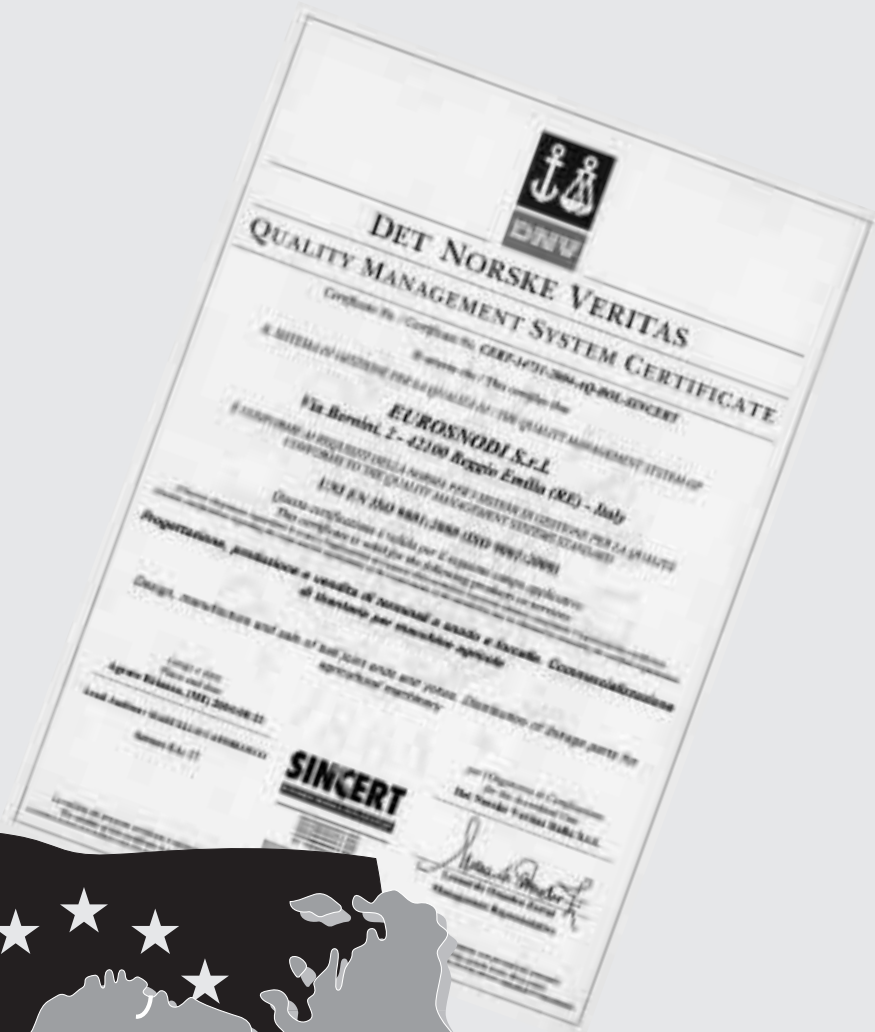

Reggio Emilia (Italy)

EuroSnodi
S.R.L.



AGRICULTURAL DIVISION



SERIE R

SUPPORTO CON ROTULA SFERICA
LOWER LINK WELD ON DENDS
UNTERLENKER-ANSCHWESSEISSAUGEN
SUPPORT AVEC ROUTULE SPHERIQUE

pag. 4-9



SERIE FF

FORCELLE FILETTATE
THREADED FORKS
GEWINDEGABELN
FOURCHES FILETEES

pag. 10



SERIE FS

FORCELLE A SALDARE
WELDING YOKES
SCHWEISSGABELN
CHAPES À SOUDER

pag. 10



SERIE 4FPC

FORCELLE
YOKES
GABELKÖPFE
CHAPES

pag. 11



SERIE 4FP

FORCELLE CON FORO FILETTATO
YOKES WITH THREADED HOLE
GABELKÖPFE MIT GEWINDEBOHRUNG
CHAPES AVEC TROU FILETÉ

pag. 11



SERIE PFC

PERNI PER FORCELLE
CLEVIS PINS
BOLZEN
TOURILLONS

pag. 12



SERIE PFT

PERNI CON TESTA
CLEVIS PINS
SPLINT BOLZEN
TOURILLONS

pag. 12



SERIE CF

CLIP PER FORCELLE
LOCKABLE PINS
ES-BOLZEN
TOURILLONS À RESSORT

pag. 12



SERIE 3TB

BRACCIO 3 PUNTO SERIE STANDARD
STANDARD TOP LINKS ZINK PLATED
OBERLENKER STANDARD VERZINKT
BARRE DE POUSSE STANDARD

» 13-14



SERIE 3TBR

BRACCIO 3 PUNTO CON GANCIO RAPIDO
TOP LINKS WITH RAPID HOOK
OBERLENKER MIT FANGHAKEN
BARRE DE POUSSEE AVEC CROCHET AUTOMATIQUE

» 15



SERIE FA

FORCELLA ARTICOLATA
ARTICULATED YOKE
GELENKGABEL
ARTICULÉ JOUG

» 16



SERIE TBM

BRACCIO CON BLOCCAGGIO A MOLLA
ARM WITH STOP SPRING
ARM MIT SPERRFEDER
BRAS AVEC RESSORT D'ARRET

» 16



SERIE IC

CATENA IMBRIGLIAENTO
CHECK CHAIN STABILIZERS
STABILISATORKETTEN
STABILISATEURS À CHAÎNE

» 17-18



SERIE SRA

STABILIZZATORE RIGIDO
RIGID STABILIZER
STABILISATOR SCHWEER
STABILISATEUR RIGIDE

» 19



SERIE CS

CLIP PER STABILIZZATORI
LEVELLING ARMS
SEITLICHER STABILISATOR MIT GABEL UND KUEGEL
CLIP POUR STABILISATEUR

» 20



SERIE SRF

STABILIZZATORE RIGIDO LATERALE FIAT
RIGID LTERAL STABILIZER FOR FIAT
STARRE UNTERLENKER STABILISATOR FIAT
ABILISATEUR RIGIDES POUR FIAT

» 20



SERIE ST

STABILIZZATORE
STABILIZER
STABILISATOR
STABILISATEUR

» 21



SERIE TCM

MANICOTTI CON TENDITORI PER CATENE
ADJUSTER FOR STABILIZERS
SPANNSCHLÖSSER
TUBE AVEC TENDEURS POUR STABILISATEURS

» 22



SERIE TM

MANICOTTI CON TENDITORI
TURNBUCKLE ASSEMBLIES
STANNSCHLÖSSER
TUBE AVEC TENDEURS

» 22



SERIE TM/L

MANICOTTI CON TENDITORI
TURNBUCKLE ASSEMBLIES
STANNSCHLÖSSER
TUBE AVEC TENDEURS

» 22



SERIE FT

TIRANTI FILETTATI CON ROTULA
TOP LINK ENDS
GEWINDESTANGEN
ROTULES A TIGESFILETEES























» 23



SERIE OP

PERNO AD OCCHIO PER CATENE
AEBOLT FOR STABILIZERS
AUGENBOLZEN
PIVOT A OEIL POUR CHAÎNES

» 23

	SERIE PTT PERNI ATTACCO ATTREZZI LOWER LINK PINS UNTERLENKERBOLZEN AXE ATTAQUE OUTILLAGE	24		SERIE SPS PERNO A SALDARE TOP LINK PINS DOPPELTE ANSCHWEISS-GERÄTEBOLZEN AXE A SOUDER	29
	SERIE GZ GRILLI ZINCATI CON PERNO A COPPIGLIA SMACKLE WITH PIN SCHÄKELN MIT BOLZEN DISPOSITIF D'ACCROCHAGE AVEC LA BISCHE	24		SERIE P2S PERNO DOPPIO A SALDARE WELD ON IMPLEMENT MOUNTING PIN DOPPELTE ANSCHWEISS-GERÄTEBOLZEN AXE DOUBLE A SOUDER	29
	SERIE PN PERNO PIN BOLZEN AXE	24		SERIE PP PERNO PIEGATO TOP LINK PINS UNTERLENKERBOLZEN AXE PLOYÉE	29
	SERIE PC CAVALLOTTO CON PERNO FORK BUGEL MIT BOLZEN ETRIER AVEC PIVOT	25		SERIE SMZ SPINOTTO MOTO ZAPPA SHAFT LOCKING PIN ROHRKLAPPSTECKER GOUPILLES A ARCEAU	30
	SERIE PDA PERNI DOPPIO ATTACCO ATTREZZI LOWER LINK PINS UNTERLENKERBOLZEN AXE DOUBLE ATTAQUE OUTILLAGE	25		SERIE FM MOLLE FERMA GANCI STOP SPRING FEERSTECLER RESSORT D'ARRET	30
	SERIE PM PERNI CON MANIGLIA TOP AND LOWER LINK PINS SICHERUNGSBOLZEN AXE AVEC POIGNÉE	25		SERIE CFG MOLLE FERMA GANCI STOP SPRING FEERSTECLER RESSORT D'ARRET	30
	SERIE PMC PERNI CON MANIGLIA SPINA E CATENA TOP AND LOWER PINS WITH CHAIN SICHERUNGSBOLZEN MIT KETTE AXE AVEC CHAINE ET GOUPILLE	26		SERIE CTR CONTRODADI PER BRACCIO 3 PUNTO LOCKING KONTERMUTTERN COLLIERS DE BLOCAGE POUR BARRES DE POUSSEE	31
	SERIE SMC SPINOTTO CON MANIGLIA E CATENA LINK PINS SICHERUNGSBOLZEN MIT HANDGRIFF BROCHES AVEC CHAINE ET POIGNEE	26		SERIE TB BARRE DI TRAINO DRAWBARS ACKERSCHIENEN BARRES A TROUS	31
	SERIE P3P PERNO 3 PUNTO TOP LINK PINS OBERLENKER-BOLZEN AXE D'ATTELAGE 3 ^{ème} POINT	27		SERIE MC MAGLIA PER CATENA QUICK LINKS RAPID GLIEDER MAILLON	32
	SERIE P3PC PERNO 3 PUNTO CON CATENA E SPINA TOP LINK PINS SICHERUNGSBOLZEN AXE D'ATTELAGE 3 ^{ème} POINT AVEC CHAINE ET GOUPILLE	27		SERIE CM COPPIGLIA A MOLLA GRIP CLIPS FEDERSTECKE GOUPILLES A RESSOT	32
	SERIE SP PERNO A SALDARE TOP LINK PINS DOPPELTE ANSCHWEISS-GERÄTEBOLZEN AXE A SOUDER	28		SERIE STO SPINE A SCATTO LINCH PINS KRAPPSPLINTE GOUPILLES CLIPS	32

SERIE R

SUPPORTO CON ROTULA SFERICA LOWER LINK WELD ON DENDS UNTERLENKER-ANSCHWEISSAUGEN SUPPORT AVEC ROUTLE SPHERIQUE

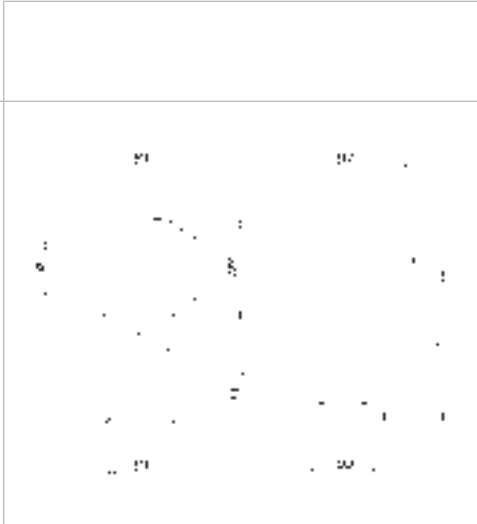

	Cod.	Cat.	D3	d	S1	D2	D1	I	F	LF
	* R 1900	-	29	16	20	27	44	45	M16x1.5	20
	R 1910	-	29	20	20	27	44	45	M18x1.5	20
	* R 1920	-	45	25	30	35	61	60	M20x1.5	25
	R 1930	-	45	30	30	35	61	60	M22x1.5	25
	* R 1940	-	59	35	40	45	80	80	M27x2	35
	R 1950	-	59	40	40	45	80	80	M30x2	35
	R 1693	-	38	14,2	44	25	53	50	-	-
	* R 1694	1	38	19,3	30	25	53	50	-	-
	R 1695	1	38	19,3	44	25	53	50	-	-
	R 1696	-	38	20,3	44	25	53	50	-	-
	* R 1700	1	38	19,3	44	30x14	58	34	-	-
	R 1702	-	38	20,3	44	30x14	58	34	-	-
	R 1704	-	38	22,2	44	30x14	58	34	-	-
	R 1707	-	38	22,2	44	34	62	58	-	-
	* R 1708	1	38	19,3	44	34	62	58	-	-
	R 1709	1	38	20,3	44	34	62	58	-	-
	* R 1710	1	38	19,3	44	34	62	60	-	-
	R 1712	1	38	22,2	44	34	62	60	-	-
	R 1720	1	38	20,3	44	34	62	60	-	-
	R 1724	1	44	19,3	35	26	62	50	-	-
	* R 1725	-	44	22,2	35	26	62	50	-	-
	R 1730	-	50	22,2	51	38	75	65	-	-
	R 1735	2	50	25,4	40	38	75	65	-	-
	R 1737	1	50	19,3	51	38	75	65	-	-
	R 1739	-	50	30,2	51	38	75	65	-	-
	* R 1740	2	50	25,4	51	38	75	65	-	-

CON FORO PER SPINA DI CENTRAGGIO
WITH HOLE FOR CENTER THOR
MIT LOCH FÜR DORN VON ZENTRIERE ICH
AVEC TROU POUR ÉPINE DE JE CENTRE

MAT.
ST. 52.3

EuroShodi

SERIE R

SUPPORTO CON ROTULA SFERICA
 LOWER LINK WELD ON DENDS
 UNTERLENKER-ANSCHWEISSAUGEN
 SUPPORT AVEC ROUTLE SPHERIQUE

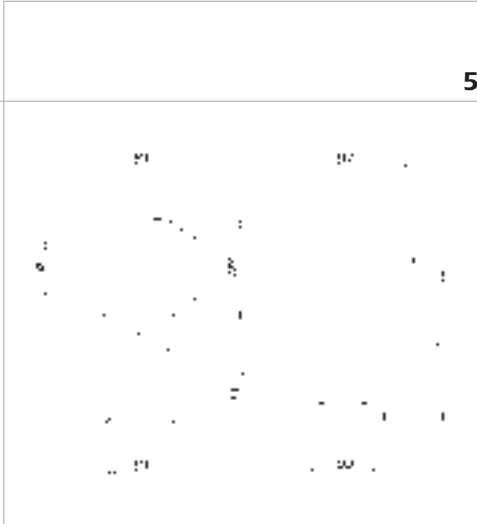

	Cod.	Cat.	D3	d	S1	D2	D1	I	F	LF
	* R 1731	1	50	19	51	35	75	55	-	-
	R 1732	-	50	22,1	51	35	75	55	-	-
	R 1736	2	50	25,4	51	35	75	55	-	-
	R 1733	-	50	28,4	51	35	75	55	-	-
	R 1738	-	50	30	51	35	75	55	-	-
	* R 1741	2	50	25,4	51	30	75	70	-	-
	* R 1742	2	50	25,4	51	45	70	70	-	-
	R 1744	1	50	19,3	51	45	70	70	-	-
	R 1746	-	50	22,2	51	45	70	70	-	-
	R 1748	-	50	30,2	51	45	70	70	-	-
	R 1756	-	50	22,2	51	50	85	70	-	-
	R 1759	1	50	19,3	51	50	85	70	-	-
	* R 1760	2	50	25,4	51	50	85	70	-	-
	R 1768	-	50	22,2	51	50	85	70	M27x2	27
	R 1769	1	50	19,3	51	50	85	70	M27x2	27
	R 1770	2	50	25,4	51	50	85	70	M27x2	27
	R 1780	-	50	30,2	51	50	85	70	-	-
	R 1790	-	50	30,2	51	50	85	70	M27x2	27
	* R 1791	2	54	25,4	51	38	90	85	-	-
	R 1792	-	54	30,2	51	38	90	85	-	-
	R 1793	3	54	32,2	51	38	90	85	-	-
	R 1794	3	54	32,2	51	38	90	85	M27x2	-
	R 1795	-	54	35,2	55	38	90	85	-	-
	R 1796	1/2	54	19,3/25,4	51	38	90	85	M27x2	-
	R 1750	2	50	25,4	51	50	83	65	-	-
	R 1800	-	54	29,2	55	50	83	65	-	-
	R 1805	-	54	30,2	42	50	83	65	-	-
	R 1807	3	54	32,2	51	50	83	65	-	-
	* R 1810	-	54	30,2	55	50	83	65	-	-
	R 1812	-	54	35,2	35	50	83	65	-	-
	R 1815	-	54	35,2	55	50	83	65	-	-

CON FORO PER SPINA DI CENTRAGGIO
 WITH HOLE FOR CENTER THOR
 MIT LOCH FÜR DORN VON ZENTRIERE ICH
 AVEC TROU POUR ÉPINE DE JE CENTRE

MAT.
 ST. 52.3

EuroShodi

SERIE R

SUPPORTO CON ROTULA SFERICA
LOWER LINK WELD ON DENDS
UNTERLENKER-ANSCHWEISSAUGEN
SUPPORT AVEC ROTULE SPHERIQUE



Cod.	Cat.	D3	d	S1	D2	D1	I	F	LF
* R 1808	-	54	30	55	45	83	65	-	-
R 1811	3	54	32	51	45	83	65	-	-
R 1814	-	54	35	55	45	83	65	-	-



R 1816	-	54	29,2	55	50	92	65	-	-
* R 1817	-	54	30,2	55	50	92	65	-	-
R 1818	-	54	30,2	42	50	92	65	-	-
R 1825	3	54	32,2	51	50	92	65	-	-
R 1819	-	54	35,2	35	50	92	65	-	-



* R 1820	-	78	40,2	75	60	108	85	-	-
R 1830	-	78	40,2	75	60	108	85	M38x2	28
R 1840	-	78	45,2	75	60	108	85	-	-
R 1850	-	78	45,2	75	60	108	85	M38x2	28
R 1860	-	78	50,2	75	60	108	85	-	-
R 1870	-	78	50,2	75	60	108	85	M38x2	28

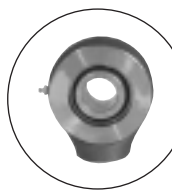

* R 1871*	-	78	40,2	75	65	128	85	-	-
R 1872*	-	78	45,2	75	65	128	85	-	-
R 1873*	-	78	50,2	75	65	128	85	-	-
R 1874*	-	78	40,2	75	65	128	85	M38x2	28
R 1875*	-	78	45,2	75	65	128	85	M38x2	28
R 1876*	-	78	50,2	75	65	128	85	M38x2	28



* R 1880*	-	98	60 (H7)	100	75	140	87	-	-
-----------	---	----	---------	-----	----	-----	----	---	---

* ROTURA RETTIFICATA

CON FORO PER SPINA DI CENTRAGGIO
WITH HOLE FOR CENTER THOR
MIT LOCH FÜR DORN VON ZENTRIERE ICH
AVEC TROU POUR ÉPINE DE JE CENTRE

MAT.
ST. 52.3

EuroSnodi

SERIE R

SUPPORTO CON ROTULA SFERICA
 LOWER LINK WELD ON DENDS
 UNTERLENKER-ANSCHWEISSAUGEN
 SUPPORT AVEC ROTULE SPHERIQUE

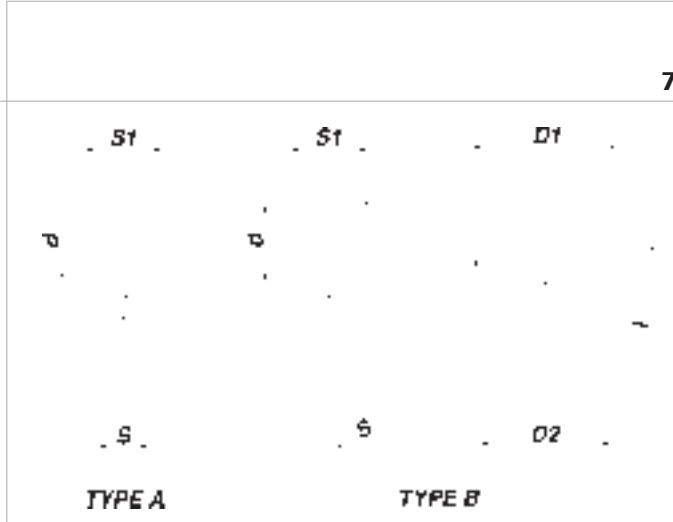

	Cod.	Cat.	D3	d	S1	D2	S	D1	I	T
	* R 1490	-	28	14,2	32	30	11	46	60	A
	R 1495	-	28	16,2	20	30	11	46	60	A
	* R 1496	-	38	19,3	44	50	17	50	50	A
	R 1497	-	44	19,3	35	50	15	65	45	A
	* R 1498	1	44	22,4	35	50	15	65	45	A
	* R 1501	1	44	22,4	35	50	15	68	90	A
	* R 1503	1	44	22,4	35	55	15	66	70	A
	* R 1508	1	44	22,4	35	60	15	65	90	B
	* R 1510	1	48	22,4	35	70	18	76	50	A
	R 1515	-	48	25,4	35	70	18	76	50	A
	R 1520	-	48	26,4	35	70	18	76	50	A
	R 1530	2	48	28,8	35	70	18	76	50	A





MAT.
ST. 52.3

EuroShodi

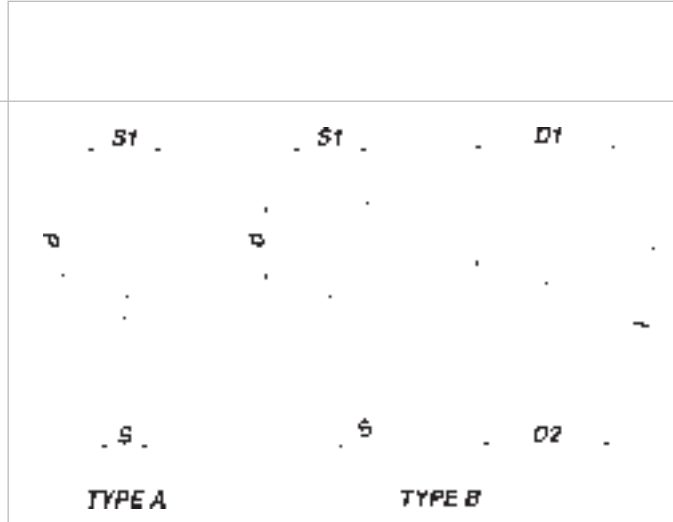
SERIE R

**SUPPORTO CON ROTULA SFERICA
LOWER LINK WELD ON DENDS
UNTERLENKER-ANSCHWEISSAUGEN
SUPPORT AVEC ROTULE SPHERIQUE**

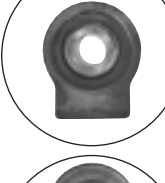
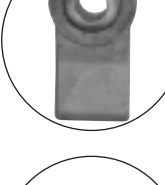
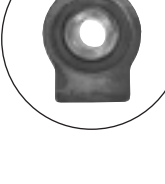

	Cod.	Cat.	D3	d	S1	D2	S	D1	I	T
	* R 1540	1	56	22,4	35	70	18	83	55	A
	R 1550	-	56	25,4	35	70	18	83	55	A
	R 1560	2	56	28,8	35	70	18	83	55	A
	R 1562	2	56	28,8	45	70	18	83	55	A
	R 1566	-	58	25,6	38	70	22	80	80	A
	R 1568	2	58	28,8	38	70	22	80	80	A
	* R 1575	2	58	28,8	45	70	22	80	80	A
	* R 1570	2	58	28,8	45	70	22	80	65	A
	R 1590	1/2	58	22,4/28,8	45	70	22	80	65	A
	* R 1579	2	56	28,8	45	76	17	90	82	A
	* R 1585	2	58	28,8	45	70	20	83	110	B
	* R 1580	2	62	28,8	45	70	22	96	65	A
	R 1597	-	62	32,2	45	70	22	96	65	A
	R 1600	-	62	34,4	45	70	22	96	65	A
	R 1602	-	62	35,3	45	70	22	96	65	A
	R 1604	3	62	37,3	45	70	22	96	65	A
	* R 1610	-	64	38,4	45	80	24	108	65	A
	R 1612	-	64	34,4	45	80	24	108	65	A
	R 1614	3	64	37,4	45	80	24	108	65	A
	R 1615	2	64	28,8	45	80	24	108	65	A
	R 1616	-	64	35,4	45	80	24	108	65	A
	R 1617	1/2	64	42,4	45	80	24	108	65	A

**MAT.
ST. 52.3**

EuroShodi

SERIE R

**SUPPORTO CON ROTULA SFERICA
LOWER LINK WELD ON DENDS
UNTERLENKER-ANSCHWEISSAUGEN
SUPPORT AVEC ROUTLE SPHERIQUE**

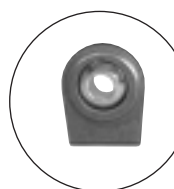
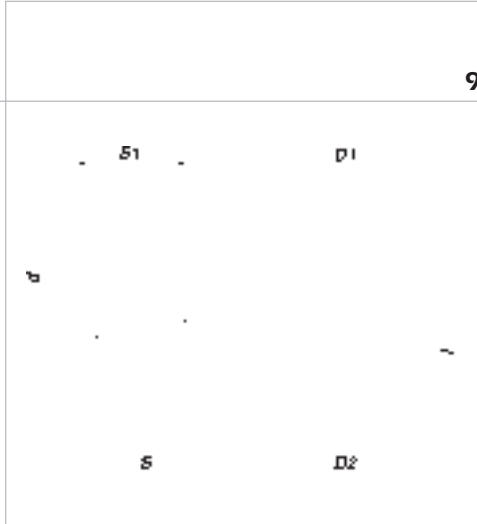

Cod.	Cat.	D3	d	S1	D2	S	D1	I
R 1499	-	44	19,3	35	56	18	67	50
* R 1500	1	44	22,4	35	56	18	67	50



* R 1505	1	44	22,4	35	56	18	67	75
-----------------	---	----	------	----	----	----	----	----



* R 1576	2	56	28,8	45	70	18	80	80
R 1577	1/2	56	22,4/28,8	45	70	18	80	80
R 1578	2	56	28,8	35	70	18	80	80

**SUPPORTO
CON ROTULA SFERICA
LOWER LINK WELD
ON DENDS
UNTERLENKER-ANSCHWEISSAUGEN
SUPPORT
AVEC ROUTLE SPHERIQUE**

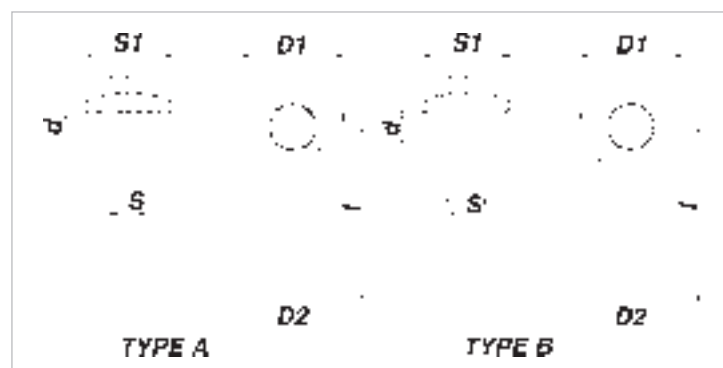

Cod.	Cat.	d	S1	D2	S	D1	I	Type	Rif. orig. FIAT
* R 1620	2	28,8	45	83	20	70	110	A	01930293

R 1621	2	28,8	45	100	34	100	125	B	-
R 1622	-	35,3	45	100	34	100	125	B	4997106
R 1624	3	37,4	45	100	34	100	125	B	-

**MAT.
ST. 52.3**

EuroShodi

SERIE FF



**FORCELLE FILETTATE
THREADED FORKS
GEWINDEGABELN
FOURCHES FILETEES**

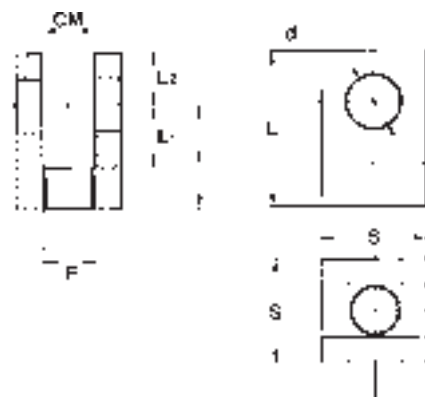

Cod.	F	CM	S	d	L	I	L1	L2
FF 0016	M 16x1,5	16	35	16,20	55	39	24	16
FF 0020	M 20x1,5	20	40	20,25	65	45	30	20
FF 0025	M 24x2	25	50	25,25	70	50	30	20
FF 0030	M 30x2	30	60	30,25	90	65	35	25
FF 0035	M 33x2	35	70	35,25	105	75	40	30

SERIE FS



**FORCELLE A SALDARE
WELDING YOKES
SCHWEISSGABELN
CHAPES À SOUDER**

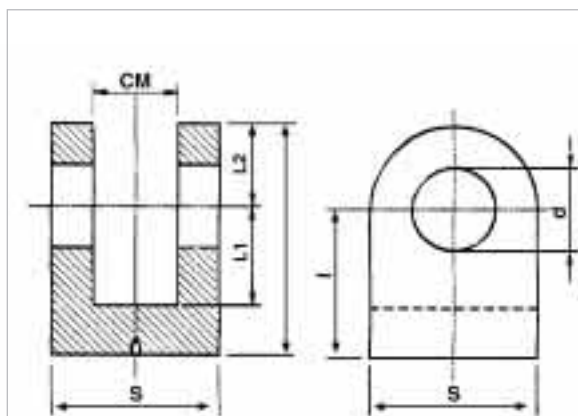

Cod.	CM	S	d	L	I	L1	L2
FS 0016*	16,2	35	16,20	50	34	24	16
FS 0020*	20,2	40	20,25	60	40	30	20
FS 0025*	25,2	50	25,25	67	45	30	22
FS 0030*	30,2	60	30,25	80	50	35	30
FS 0035*	35,2	70	35,25	90	55	40	35

* I PARTICOLARI HANNO FORO DI CENTRAGGIO PER SPINA DI 4 MM, QUESTO PERMETTE DI AGEVOLARE L'OPERAZIONE DI CENTRAGGIO PER LA SALDATURA

* THE PARTS HAVE A CENTRING HOLE FOR 4 MM. PLUG: THIS FACILITATES CENTRING FOR SOLDERING

* DIE TEILE HABEN EINE ZENTRIERUNGSBOHRUNG FÜR EINEN ZAPFEN VON 4 MM, DIE ZENTRIERUNG FÜR DAS SCHWEISSEN ERLEICHTERT

* LES PIÈCES SPÉCIALES ONT UN TROU DE CENTRAGE POUR GOUPILLE DE 4 MM. CECI PERMET DE FACILITER L'OPÉRATION DE CENTRAGE POUR LE SOUDAGE

EuroSnodi

SERIE 4FP C

DIN 71752
ISO 8140 (CETOP)

FORCELLE
YOKES
GABELKÖPFE
CHAPES

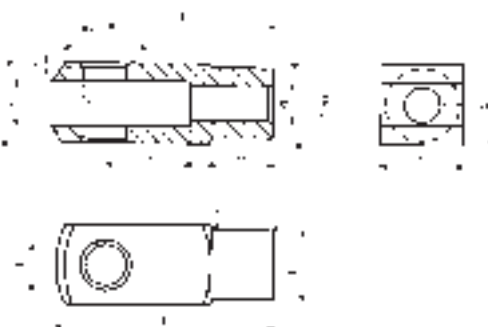

Cod.	Passo del filetto Thread lead Gewindegang Pas du filet	a	Valori tolleranza Tolerance values Toleranzwerte Valeurs de tolérance a [B12]	b	d1	Valori tolleranza Tolerance values Toleranzwerte Valeurs de tolérance d1 (H8)	d2	e	f	L	L1	n	r
4FP 10x20C	10x1,25	10	+0,150 +0,300	20	10	+0,022 0	18	15	0,5	52	40	20	0,5
4FP 12x24C	12x1,25	12	+0,150 +0,330	24	12	+0,027 0	20	18	0,5	62	48	24	0,5
4FP 16x32C	16x1,5	16	+0,150 +0,330	32	16	+0,027 0	26	24	1	83	64	32	1
4FP 20x40C	20x1,5	20	+0,160 +0,370	40	20	+0,033 0	34	30	1	105	80	40	1
4FP 25x50C	24x2	25	+0,160 +0,370	50	25	+0,033 0	42	36	1	132	100	50	1
4FP 30x54C	27x2	30	+0,160 +0,370	55	30	+0,033 0	48	38	1	148	110	54	1
4FP 35x72C	36x2	35	+0,170 +0,420	70	35	+0,039 0	60	40	1	188	144	72	1

SERIE 4FP

UNI 1676
DIN 71752

FORCELLE CON FORO FILETTATO
YOKES WITH THREADED HOLE
GABELKÖPFE MIT GEWINDEBOHRUNG
CHAPES AVEC TROU FILETÉ

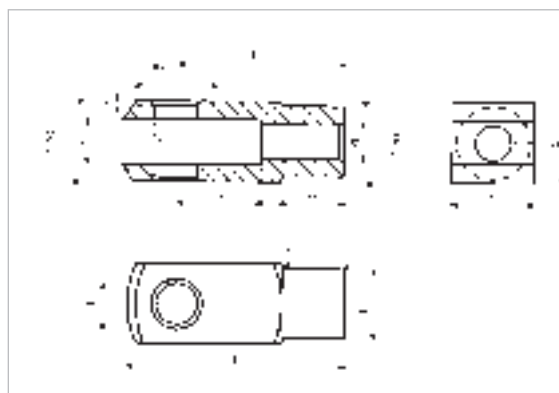

Cod.	Passo del filetto Thread lead Gewindegang Pas du filet	a	Valori tolleranza Tolerance values Toleranzwerte Valeurs de tolérance a [B12]	b	d1	Valori tolleranza Tolerance values Toleranzwerte Valeurs de tolérance d1 (H8)	d2	e	f	L	L1	n	r
4FP 4x8	4x0,7	4	+0,140 +0,260	8	4	-0 +0,018	8	6	0,5	21	16	8	-
4FP 5x10	5x0,8	5	+0,140 +0,260	10	5	-0 +0,018	9	7,5	0,5	26	20	10	-
4FP 6x12	6x1	6	+0,140 +0,260	12	6	-0 +0,018	10	9	0,5	31	24	12	-
4FP 8x16	8x1,25	8	+0,150 +0,300	16	8	-0 +0,022	14	12	0,5	42	32	16	-
4FP 10x20	10x1,5	10	+0,150 +0,300	20	10	-0 +0,022	18	15	0,5	52	40	20	-
4FP 12x24	12x1,75	12	+0,150 +0,330	24	12	-0 +0,027	20	18	0,5	62	48	24	-
4FP 14x28	14x2	14	+0,150 +0,330	27	14	-0 +0,027	24	22,5	1	72	56	28	-
4FP 16x32	16x2	16	+0,150 +0,330	32	16	-0 +0,027	26	24	1	83	64	32	-
4FP 20x40	20x2,5	20	+0,160 +0,370	40	20	-0 +0,033	34	30	1	105	80	40	-
4FP 25x50	24x3	25	+0,160 +0,370	50	25	+0,033 0	42	36	1	132	100	50	-

H8 dopo zincatura. FeZn7 UNI 4721. A richiesta superficie grezza oliata • H8 AFTER ZINC PLATING TREATMENT. FeZn7 UNI 4721. UNFINISHED AND OILED SURFACE ON REQUEST
H8 NACH VERZINKUNG. FeZn7 UNI 4721. AUF WUNSCH BLANKE UND GEOLTE OBERFLÄCHE • H8 APRÈS TRAITEMENT DE ZINGAGE. FeZn7 UNI 4721. SURFACE BRUTE HUILÉE SUR DEMANDE

EuroSnodi

SERIE PFC

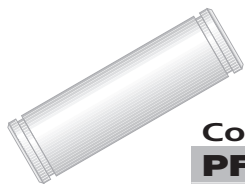

NORMA ISO
(CETOP)

PERNI PER FORCELLE
CLEVIS PINS
BOLZEN
TOURILLONS

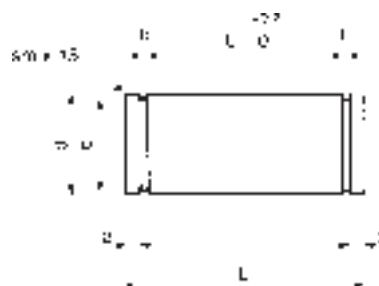

Cod.	d	L	d1	L1	a	b
PF10C	10	25	9,6	20	1,5	1,1
PF12C	12	30	11,5	24	2	1,1
PF16C	16	39	15,2	32	2,4	1,1
PF20C	20	48	19	40	2,9	1,3
PF25C	25	60	23,9	50	3,7	1,3
PF30C	30	65	28,6	55	3,4	1,6
PF35C	35	84	33,4	70	5,4	1,6

SERIE PFT



UNI 1710
DIN 1434

PERNI CON TESTA
CLEVIS PINS
SPLINT BOLZEN
TOURILLONS

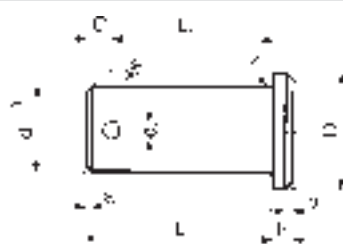

Cod.	d	L	h	a	b	D	r	d1	c	L1
PFT5	5	14	1,5	1	0,5	8	0,5	1,5	3	11
PFT6	6	16	1,5	1	0,5	9	0,5	2	3	13
PFT8	8	20	2	1	0,5	12	0,5	2	3	17
PFT10	10	25	2	1,5	0,5	14	0,5	3	3,5	21,5
PFT12	12	30	3	1,5	1	16	0,5	3	3,5	26,5
PFT14	14	35	3	1,5	1	19	1	4	4	31
PFT16	16	40	3	1,5	1	20	1	4	4	36

SERIE CF



CLIP PER FORCELLE
LOCKABLE PINS
ES-BOLZEN
TOURILLONS À RESSORT

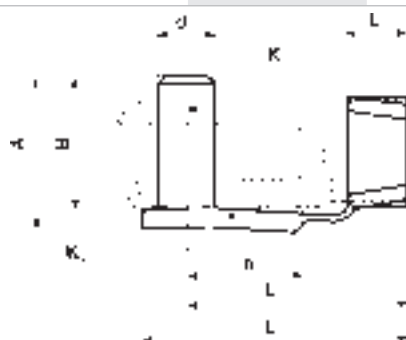

Cod.	d1	n	A	B	L	L1	L2
CF 4x8	4	8	11	9	19	15	5
CF 5x10	5	10	13,5	12	23	19	6
CF 6x12	6	12	16	14	28	23	6
CF 8x16	8	16	22	19	37	31	8
CF 10x20	10	20	26	23	46	39	10
CF 12x24	12	24	32	28	55	47	12
CF 14x28	14	28	35	31	62	52	14
CF 16x32	16	32	40	36	72	62	14
CF 20x40	20	40	48	44	88	72	16

SERIE 3TB

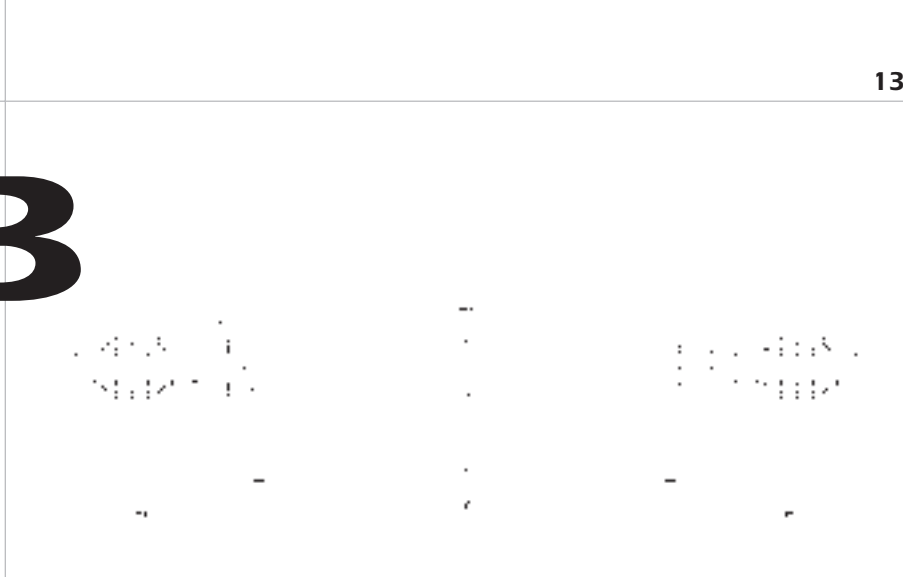

BRACCIO 3 PUNTO SERIE STANDARD
STANDARD TOP LINKS ZINK PLATED
OBERLENKER STANDARD VERZINKT
BARRE DE POUSSER STANDARD

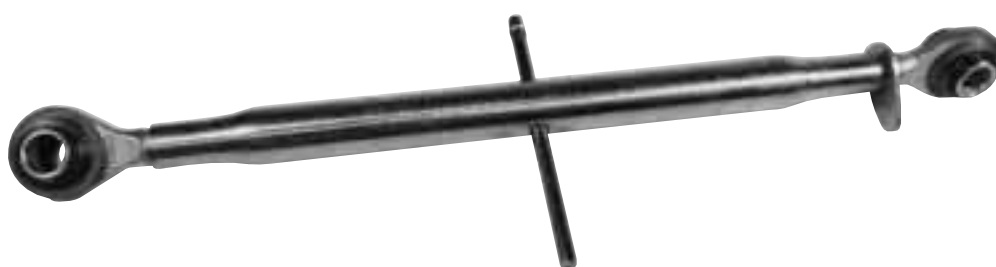

Cod.	Cat.	D	F	E	A min./max
3TB 1801	1	19,3	22x2,5	180	300-380
3TB 2201	1	19,3	22x2,5	220	345-500
3TB 2751	1	19,3	27x3	275	400-500
3TB 2752	2	25,4	27x3	275	410-560
3TB 3201	1	19,3	27x3	320	430-640
3TB 3202	2	25,4	27x3	320	450-680
3TB 320D	1/2	19,3/25,4	27x3	320	445-660
3TB 3501	1	19,3	27x3	350	465-690
3TB 3502	2	25,4	27x3	320	480-700
3TB 3801	1	19,3	27x3	380	500-710
3TB 3802	2	25,4	27x3	380	520-750
3TB 4001	1	19,3	27x3	400	515-720
3TB 4002	2	25,4	27x3	400	540-770
3TB 400D	1/2	19,3/25,4	27x3	400	535-760
3TB 4501	1	19,3	27x3	450	560-780
3TB 4502	2	25,4	27x3	450	595-820
3TB 450D	1/2	19,3/25,4	27x3	450	565-790
3TB 5001	1	19,3	27x3	500	615-830
3TB 5002	2	25,4	27x3	500	620-850
3TB 500D	1/2	19,3/25,4	27x3	500	630-860
3TB 5501	1	19,3	27x3	550	635-850
3TB 5502	2	25,4	27x3	550	650-880
3TB 550D	1/2	19,3/25,4	27x3	550	645-860
3TB 5702	2	25,4	27x3	570	715-940

SERIE 3TB



BRACCIO 3 PUNTO SERIE PESANTE
HEAVY DUTY TOP LINKS ZINK
OBERLENKER SCHWER VERZINKT
BARRE DE POUSSE



Cod.	Cat.	D	F	E	A min./max
3TB 4001P	1	19,3	30x3	400	515-760
3TB 4002P	2	25,4	30x3	400	520-770
3TB 400DP	1/2	19,3/25,4	30x3	400	520-770
3TB 4501P	1	19,3	30x3	450	560-800
3TB 4502P	2	25,4	30x3	450	570-820
3TB 450DP	1/2	19,3/25,4	30x3	450	560-800
3TB 5001P	1	19,3	30x3	500	620-870
3TB 5002P	2	25,4	30x3	500	630-880
3TB 500DP	1/2	19,3/25,4	30x3	500	630-880
3TB 6501P	1	19,3	30x3	650	760-1000
3TB 6502P	2	25,4	30x3	650	770-1010
3TB 7202P	2	25,4	30x3	720	840-1090
3TB 5502P	2	25,4	30x3	550	670-920
3TB 4002S	2	25,4	36x3	400	530-770
3TB 4003S	3	32	36x3	400	560-850
3TB 4602S	2	25,4	36x3	460	680-860
3TB 4603S	3	32	36x3	460	620-900
3TB 5202S	2	25,4	36x3	520	640-860
3TB 5702S	2	25,4	36x3	570	690-910
3TB 4002L	2	25,4	40x3	400	530-770
3TB 5002L	2	25,4	40x3	500	630-870
3TB 6202L	2	25,4	40x3	620	760-990

SERIE 3TBR

BRACCIO 3 PUNTO CON GANCIO RAPIDO
TOP LINKS WITH RAPID HOOK
OBERLENKER MIT FANGHAKEN
BARRE DE POUSSEE AVEC CROCHET
AUTOMATIQUE



Cod.	Cat.	d	h	D	L1	L min./max	Cat. E
3TBR 3202 GC	2	25,4	51	27x3	320	505-745	2
3TBR 3702 GC	2	25,4	51	27x3	370	555-795	2
3TBR 4302 GC	2	25,4	51	27x3	430	615-855	2
3TBR 4702 GC	2	25,4	51	27x3	470	655-895	2
3TBR 5702 GC	2	25,4	51	27x3	570	755-995	2
3TBR 3602 PGC	2	25,4	51	27x3	320	505-745	2
3TBR 4202 PGC	2	25,4	51	30x3	420	605-845	2
3TBR 4602 PGC	2	25,4	51	30x3	460	645-885	2
3TBR 5202 PGC	2	25,4	51	30x3	520	705-945	2
3TBR 4002 SGC	2	25,4	51	36x3	400	620-940	2
3TBR 4602 SGC	2	25,4	51	36x3	460	680-1000	2
3TBR 5202 SGC	2	25,4	51	36x3	520	740-1060	2
3TBR 5802 SGC	2	25,4	51	36x3	580	800-1120	2
3TBR 4003 SGC	3	32	51	36x3	400	620-940	3-2
3TBR 4603 SGC	3	32	51	36x3	460	680-1000	3-2
3TBR 5203 SGC	3	32	51	36x3	520	740-1060	3-2

SERIE FA

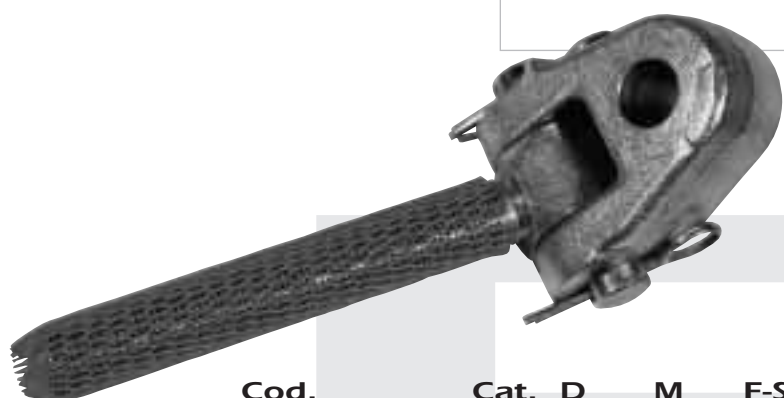

**FORCELLA ARTICOLATA
ARTICULATED YOKE
GELENKGABEL
ARTICULÉ JOUG**

Cod.	Cat.	D	M	F-Sx	L	E	H	D	A	G	V
FA 302525	2	25,4	250	30x3	75	68	64	25	25,2	100	30
FA 302532	2	25,4	220	30x3	100	92	87	25	32,2	120	40
FA 362825	3	32	220	36x3	100	92	87	28	25,2	120	40
FA 362828	3	32	220	36x3	88	80	75	28	28,2	110	40

SERIE TBM

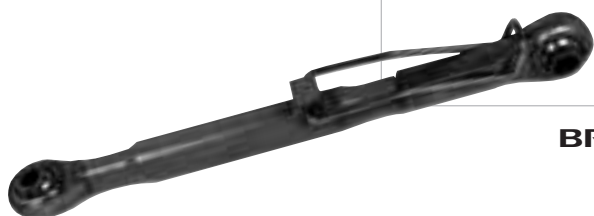

**BRACCIO CON BLOCCAGGIO A MOLLA
ARM WITH STOP SPRING
ARM MIT SPERRFEDER
BRAS AVEC RESSORT D'ARRET**

Cod.	Cat.	D	H	D1	L1	L min.	L max
TBM 318 JD	1/2	19/25,4	44/51	27x3	318	545	790

EuroShodi

SERIE IC

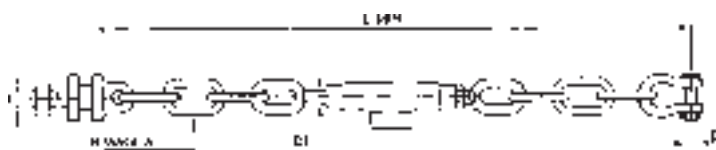

**CATENA IMBRIGLIAMENTO
CHECK CHAIN STABILIZERS
STABILISATORENKETTEN
STABILISATEURS À CHAÎNE**



Cod.	N MANIGLIE	Ø MAGLIA mm	L. MIN. mm	D mm	DF mm	F mm	Adattabile a:
IC440S	1+1	12	440	14	M20x2,5	20	same
IC570S	2+2	12	570	14	M20x2,5	20	same
IC690S	3+3	12	690	14	M20x2,5	20	same
IC620S	3+2	12	620	14	M20x2,5	20	same
IC460S	3+1	10	460	14	M16x2	18	same
IC500S	2+1	14	500	16	M20x2,5	24	same explorer
IC620LP	3+2	12	620	14	M20x2,5	20	landini (con piastra, Fiat, Flack)
IC570LP	2+2	12	570	14	M20x2,5	20	landini (con piastra, Fiat, Flack)

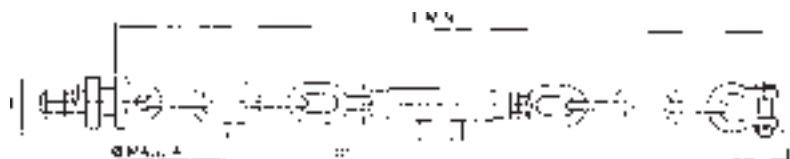

Cod.	N MANIGLIE	Ø MAGLIA mm	L. MIN. mm	D mm	DF mm	F mm	Adattabile a FIAT:
IC430F1	1+1	14	430	14-14	M16x2	22	FIAT 5130634
IC370F	1+1	12	370	14-14	M16x2	22	FIAT 5131390
IC450F	2+1	12	450	14-14	M16x2	22	FIAT 5116366
IC430F	2+2	12	430	12	M16x2	18	FIAT 5002501
IC490F	3+3	12	490	12	M16x2	18	FIAT 5002499
IC570F	4+4	12	570	12	M16x2	18	FIAT 5002545
IC670F	4+3	18	670	16	M22x2,5	20	FIAT805 4988796

EuroShodi

SERIE IC

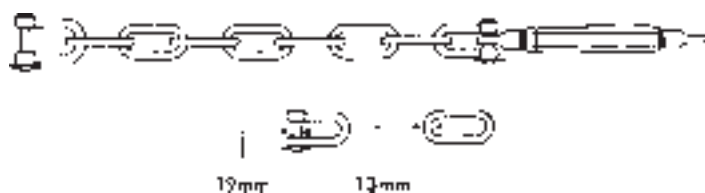

**CATENA IMBRIGLIAMENTO PER TRATTORI
CHECK FOR TRACTORS
STABILISATORENKETTEN FÜR SCHLEPPER
STABILISATEURS À CHAÎNE POUR TRACTEURS**



IC 400 FDR

adattabile a
adaptable to
passend zu
adaptable a

FORD 4000

MIN 511 - MAX 574



IC 500 FDR

adattabile a
adaptable to
passend zu
adaptable a

FORD 5000

MIN 594 - MAX 657



IC 820 ST

MIN 819 - MAX 927

EuroShodi

SERIE SRA



STABILIZZATORE RIGIDO LATERALE
RIGID LATERAL STABILIZER
STABILISATOR SCHWERE
STABILIZATEUR RIGIDE LATERAL



Cod.	d	h	D	D1	D2	L	L1
SRA 005	19	44	24x2,5	20	20x2,5	470-620	355
SRA 006	19	44	27x3	24	24x2	440-600	315
SRA 007	25,4	51	27x3	24	24x2	440-600	315
SRA 008	19	44	27x3	24	24x2	510-670	395
SRA 008	25,4	51	27x3	24	24x2	510-670	395



STABILIZZATORE RIGIDO
RIGID STABILIZER
STABILISATOR SCHWEER
STABILIZATEUR RIGIDE



Cod.	d	h	D	D1	L min.	L1
SRA 010	22,1	35	24x3	18,5	570	465
SRA 011	22,1	35	24x3	18,5	690	585
SRA 012	28,4	45	27x3	18,5	655	525

SERIE CS

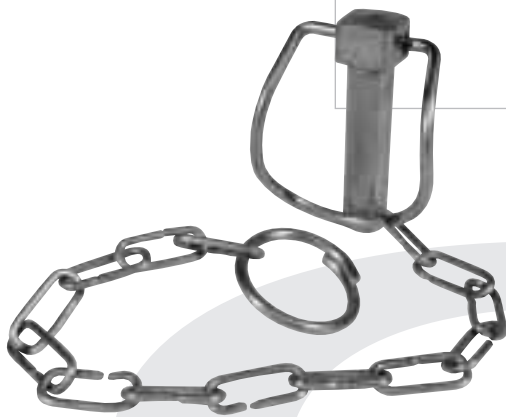

CLIP PER STABILIZZATORI
LEVELLING ARMS
SEITLICHER STABILISATOR MIT GABEL
UND KUEGEL
CLIP POUR STABILIZATEUR

Cod.	F Mn	A mm	B mm	C mm	E mm	G mm	Ø Albero motore
CS 3012	12	64	12	49	18	4	da 30 a 35
CS 3014	14	67	15	50	18	4	da 30 a 35
CS 3016	16	67	13	47	20	4	da 30 a 35
CS 3019	19	88	14	59	25	5	da 30 a 38

SERIE SRF



STABILIZZATORE RIGIDO LATERALE FIAT
RIGID LTERAL STABILIZER FOR FIAT
STARRE UNTERLENKER STABILISATOR FIAT
STABILIZATEUR RIGIDES POUR FIAT

Cod.	L Mn	d1	H	d	Modello Schlepper Tractor Type	Cod. FIAT
SRF 480	480	25,4	51	28	1180-1380-1580-1880-115/90 130/90-140/90-160/90-180/90	5109518
SRF 400/73 SRF 400/70	400	19	44	26	660-680-680H-766-780-880-980 70/66-80/66-70/90-80/90-90/90-100/90	512273 5113070

EuroShodi

SERIE ST



**STABILIZZATORE
STABILIZER
STABILISATOR
STABILIZATEUR**

Cod.	L	Ø	L	L1
ST 3644	45	13	200	360
ST 56725	45	22	400	560



**STABILIZZATORE
STABILIZER
STABILISATOR
STABILIZATEUR**



Cod.	L	Ø	L	L1
ST 6499	45	25	550	645-990

EuroSnodi

SERIE TCM



MANICOTTI CON TENDITORI PER CATENE
ADJUSTER FOR STABILIZERS
SPANNSCHLÖSSER
TUBE AVEC TENDEURS POUR STABILISATEURS

Cod.	A mm	B mm	F	D mm	E mm
TCM 16216	245	120	16x2	35	16
TCM 182515	250	135	18x2,5	39	15
TCM 202514	275	130	20x2,5	38	14
TCM 222514	280	150	22x2,5	38	14

SERIE TM

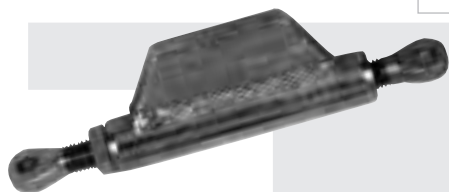

MANICOTTI CON TENDITORI
TURNBUCKLE ASSEMBLIES
STANNSCHLÖSSER
TUBE AVEC TENDEURS

Cod.	A	B	A min./max
TM 273	13	171	273-368
TM 235	13	171	235-330

SERIE TM/L



MANICOTTI CON TENDITORI
TURNBUCKLE ASSEMBLIES
STANNSCHLÖSSER
TUBE AVEC TENDEURS

Cod.	A	B	A min./max
TM/L 254	13	153	254-349

SERIE FT



**TIRANTI FILETTATI CON ROTULA
TOP LINK ENDS
GEWINDESTANGEN
ROTULES A TIGESFILETEES**

Cod.	Cat.	A	F	C	B	E	ADATTABILE A
FT1930DX	1	19,2	30x3	228	170	44	3TB 4001P, 4002P, 400DP
FT1930SX	1	19,2	30x3	228	170	44	4501P, 4502P, 450DP, 5001P,
FT2530DX	2	25,4	30x3	222	165	51	5002P, 500DP, 5502P, 6501P,
FT2530SX	2	25,4	30x3	222	165	51	6502P, 7202P.
FT1930DX35	1	19,2	30x3,5	228	170	44	3TB 3001P35, 3002P35, 300DP35
FT1930SX35	1	19,2	30x3,5	228	170	44	3501P35, 3502P35, 350DP35, 4001P35,
FT2530DX35	2	25,4	30x3,5	222	165	51	4002P35, 400DP35, 4501P35, 4502P35,
FT2530SX35	2	25,4	30x3,5	222	165	51	450DP35, 5001P35, 5002P35, 500DP35.
FT2536DX	2	25,4	36x3	225	170	51	3TB 4002S, 4003S, 4602S
FT2536SX	2	25,4	36x3	225	170	51	4603S, 5202S, 5702S
FT3236DX	3	32,4	36x3	260	195	51	3602S, 3802S, 5003S, 5203S, 5703S.
FT3236SX	3	32,4	36x3	260	195	51	
FT2536SDX	2	25,4	36x3	260	195	51	3TB4002SS, 4602SS,
FT2536SSX	2	25,4	36x3	260	195	51	5002SS, 5202SS, 5702SS.
FT2540DX	2	25,4	40x3	230	170	51	3TB 4002L, 5002L,
FT240SX	2	25,4	40x3	230	170	51	6202L.

SERIE OP

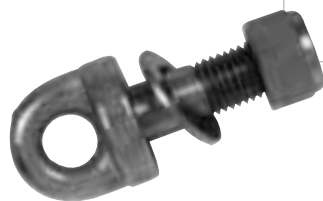

**PERNO AD OCCHIO PER CATENE
AYEBOLT FOR STABILIZERS
AUGENBOLZEN
PIVOT A OEIL POUR CHAÎNES**

Cod.	A mm	B mm	F	C mm	D mm
OP 1615	36	80	16x1,5	43	15
OP 1615 B	36	80	18x2,5	43	15
OP 1618	45	100	20x2,5	56	18
OP 1625	53	125	24x2	65	20
OP 1620	53	125	20x2,5	65	20

SERIE PTT



PERNI ATTACCO ATTREZZI
LOWER LINK PINS
UNTERLENKERBOLZEN
AXE ATTAQUE OUTILLAGE

Cod.	D	D1	D2	D3	H	L	L1	L2	L3	L4	L5	d
PTT 1064	22	37	18x1,5	18	12	130	68	45	0,5	50	46	12
PTT 1065	22	35	20x1,5	20	12	130	70	46	0,5	50	46	12
PTT 1060	22	38	22x1,5	22	12	140	75	40	14	54	50	12
PTT 1050	22	38	22x1,5	28	12	140	73	40	14	55	50	12
PTT 1070	28	43	22x1,5	22	12	150	80	46	14	60	60	12
PTT 1075	28	42	22x1,5	24	12	150	80	45	14	60	55	12
PTT 1080	28	43	24x1,5	24	12	150	78	45	15	60	55	12
PTT 1055	28	43	22x1,5	28	12	150	80	40	20	60	60	12
PTT 1085	28	42	27x1,5	28	12	150	80	46	14	60	55	12

SERIE GZ



GRILLI ZINCATI CON PERNO A COPPIGLIA
SHACKLE WITH PIN
SCHÄKELN MIT BOLZEN
DISPOSITIF D'ACCROCHAGE AVEC LA BISCHE

Cod.	Port. kg	D Ø mm.	D Ø poli	H mm.	L mm.
GZ 1012	850	12	1/2"	18	40
GZ 1014	850	14	9/16"	18	40
GZ 1016	950	16	5/8"	20	54

SERIE PN

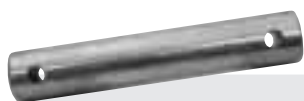

PERNO - PIN
BOLZEN - AXE

Cod.	A	B	C	D
PN 64	18	52	6	64
PN 74	18	62	6	74
PN 84	18	72	6	84

SERIE PC



CAVALLOTTO CON PERNO
FORK
BUGEL MIT BOLZEN
ETRIER AVEC PIVOT

Cod.	A	B	C	D	E
PC 2005	60	108	19	10	55

SERIE PDA



PERNI DOPPIO ATTACCO ATTREZZI
LOWER LINK PINS
UNTERLENKERBOLZEN
AXE DOUBLE ATTAQUE OUTILLAGE

Cod.	A	B	C	D	E	F	G	H	I	L
PDA 1270	48	42	13,5	58	28	27x1,5	22	28	14	12
PDA 1275	52	42	12	60	25	24,5	22	28	14	12

SERIE PM

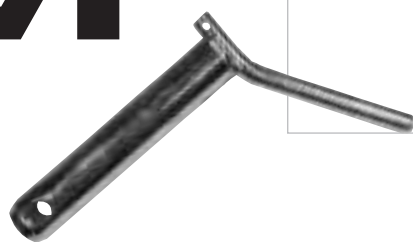

PERNI CON MANIGLIA
TOP AND LOWER LINK PINS
SICHERUNGSBOLZEN
AXE AVEC POIGNÉE

Cod.	A	B	C
PM 271	19	130	12
PM 272	19	175	12
PM 273	22	130	12
PM 274	22	175	12
PM 275	25	130	12
PM 276	25	175	12
PM 277	28	130	12
PM 278	28	175	12
PM 279	32	175	12

SERIE PMC



PERNI CON MANIGLIA SPINA E CATENA
TOP AND LOWER PINS WITH CHAIN
SICHERUNGSBOLZEN MIT KETTE
AXE AVEC CHAÎNE ET GOUPILLE

Cod.	A	B	C
PMC 271 CC	19	130	12
PMC 272 CC	19	175	12
PMC 273 CC	22	130	12
PMC 274 CC	22	175	12
PMC 275 CC	25	130	12
PMC 276 CC	25	175	12
PMC 277 CC	28	130	12
PMC 278 CC	28	175	12
PMC 279 CC	32	175	12

SERIE SMC



SPINOTTO CON MANIGLIA E CATENA
LINK PINS
SICHERUNGSBOLZEN MIT HANDGRIFF
BROCHES AVEC CHAÎNE ET POIGNEE

Cod.	A	B	C
SMC 401	19	112	6
SMC 402	19	162	6
SMC 403 C	22	125	6
SMC 403	22	162	6
SMC 404	25	162	6
SMC 405	28	162	6
SMC 406	28	187	6
SMC 407	32	187	6

SERIE P3P

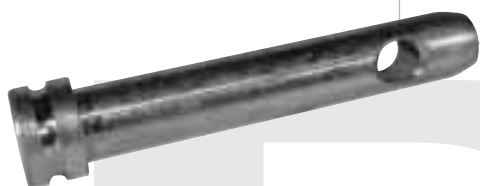

PERNO 3 PUNTO
TOP LINK PINS
OBERLENKER-BOLZEN
AXE D'ATTELAGE 3^{eme} POINT

Cod.	Cat.	D	A	B	C	D	E
P3P 132	1	19,3	108	85	15	12	19
P3P 133	2	25,4	110	95	15	12	25
P3P 134 C3	3	32	145	125	20	12	31

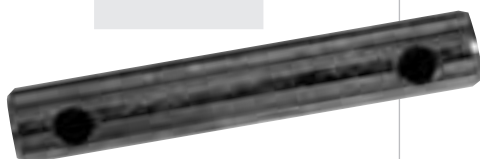

Cod.	Cat.	D	L	L1	L2	d
P3P 1400	1	19	96	140	22	12
P3P 1420	1	19	163	207	22	12
P3P 1430	1	19	210	254	22	12
P3P 1460	2	25	120	120	22	12
P3P 1480	2	25	210	210	22	12
P3P 1490	2	25	250	250	22	12

SERIE P3PC



PERNO 3 PUNTO CON CATENA E SPINA
TOP LINK PINS
SICHERUNGSBOLZEN
AXE D'ATTELAGE 3^{eme} POINT
AVEC CHAINE ET GOUPILLE

Cod.	L	B	A	Ø
P3PC 130	122	100	11	19
P3PC 130	125	104	11	25,4

EuroSnodi

SERIE SP



PERNO A SALDARE
TOP LINK PINS
DOPPELTE ANSCHVE I SS-GERÄTEBOLZEN
AXE A SOUDER

Cod.	D	D1	L1	L2
SP 1203	19	25	90	90
SP 1204	22	28	90	90



Cod.	D1-D2	D	L1	L2	L3
SP 2150	19	25	70	40	100
SP 2140	22	28	70	40	100
SP 2160	25	32	90	50	110
SP 2170	28	36	100	50	120

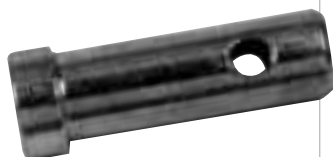

Cod.	A	B	C	D	E	d
SP 1500	60	80	95	28	22	11,5
SP 1510	60	80	95	34	28	11,5

SERIE SPS

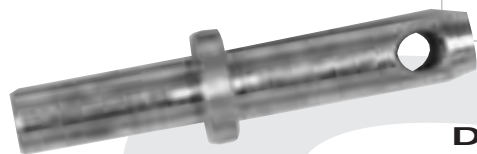

PERNO A SALDARE
TOP LINK PINS
DOPPELTE ANSCHVE I SS-GERÄTEBOLZEN
AXE A SOUDER

Cod.	A	B	C	R	T
SP S 541	50	80	22	32	22
SP S 542	60	90	25	38	22
SP S 543	60	90	28	38	22

SERIE P 2S

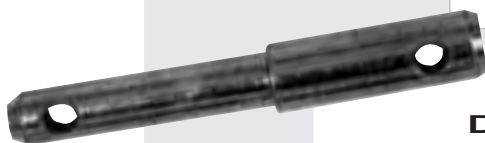

PERNO DOPPIO A SALDARE
WELD ON IMPLEMENT MOUNTING PIN
DOPPELTE ANSCHWEISS-GERÄTEBOLZEN
AXE DOUBLE A SOUDER

Cod.	A	B	C	D	E
P 2S 150	85	62	28	22	12

SERIE PP

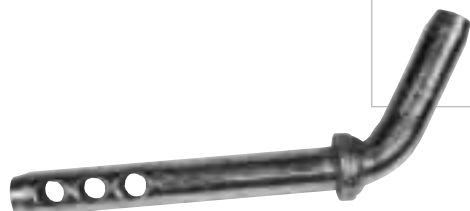

PERNO PIEGATO
TOP LINK PINS
UNTERLENKERBOLZEN
AXE PLOYÉ

Cod.	D	L	I	V1
PP 19	19	160	90	95
PP 22	19	160	90	95

SERIE SMZ

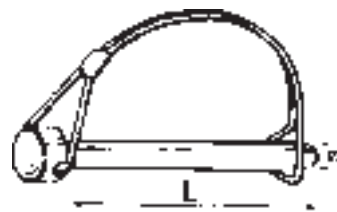

**SPINOTTO MOTO ZAPPA
SHAFT LOCKING PIN
ROHRKLAPPSTECKER
GOUPILLES A ARCEAU**

Cod.	L	Ø mm	CONF. MIN.
SMZ 108	70	8	50
SMZ 110	70	10	50
SMZ 108C	45	8	50
SMZ 110C	45	10	50
SMZ 112	70	12	50

SERIE FM

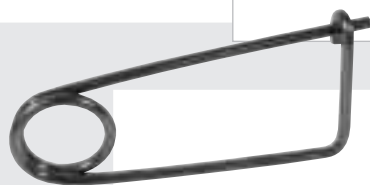
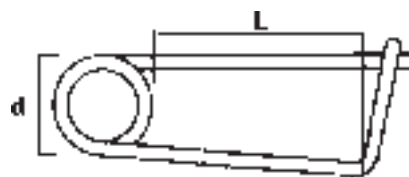

**MOLLE FERMA GANCI
STOP SPRING
FEERSTECLER
RESSORT D'ARRET**

Cod.	Ø mm	d	L
FM 104	4	33	100
FM 105	5	31	90
FM 106	6	30	100

SERIE CFG

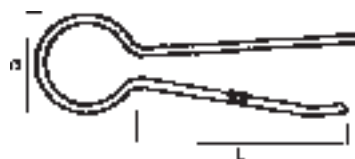

**MOLLE FERMA GANCI
STOP SPRING
FEERSTECLER
RESSORT D'ARRET**

Cod.	Ø mm	d	L
CFG 103	3	17	38
CFG 105	5	27	56

SERIE CTR



**CONTRODADI PER BRACCIO 3 PUNTO
LOCKING- KONTERMUTTERN
COLLIERS DE BLOCAGE POUR
BARRES DE POUSSEE**

Cod.	d	A	B	C
CTR 022	22x2,5	60	45	6
CTR 027	27x3	60	45	6
CTR 030	30x3	60	45	6
CTR 036	36x3	88	60	10
CTR 040	40x3	88	60	10

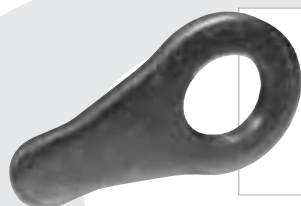

Cod.	d	A	B	C
CTR 022S	22x2,5	60	45	6
CTR 027S	27x3	60	45	6
CTR 030S	30x3	60	45	6
CTR 036S	36x3	88	60	10
CTR 040S	40x3	88	60	10

SERIE TB

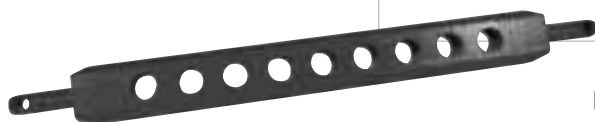

**BARRE DI TRAINO
DRAWBARS - ACKERSCHIENEN
BARRES A TROUS**

Cod.	A	B	C	D	E	F	N
TB 4201	420	63	25	57	22	22	4
TB 5402	540	63	30	70	22	28	5
TB 6621	625	63	30	50	22	22	9
TB 7201	720	63	30	58	22	22	9
TB 8001	800	63	30	58	22	22	9
TB 8002	800	63	30	70	22	28	9
TB 9002	900	63	30	70	22	28	9
TB 9622 L	930	63	30	55	22	28	11
TB 9622	933	75	30	55	22	28	11
TB 930 PSA	890	80	30	63	22	28	6

SERIE MC

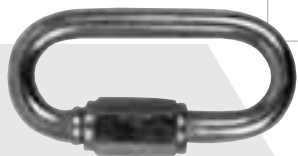

MAGLIA PER CATENA - QUICK LINKS
RAPID GLIEDER - MAILLON

Cod.	Ø mm
MC 104	4
MC 105	5
MC 106	6
MC 107	7

Cod.	Ø mm
MC 108	8
MC 109	9
MC 110	10
MC 112	12

SERIE CM

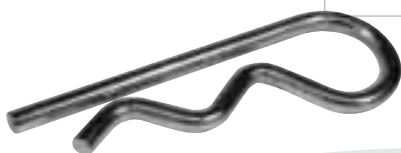

COPPIGLIA A MOLLA - GRIP CLIPS
FEDERSTECKE - GOUPILLES A RESSOT

Cod.	Ø mm
CM 110 D2	2
CM 110 D25	2,5
CM 110 D3	3
CM 110 D35	3,5
CM 110 D4	4

Cod.	Ø mm
CM 110 D45	4,5
CM 110 D5	5
CM 110 D6	6
CM 110 D8	8

SERIE STO



SPINE A SCATTO - LINC H PINS
KRAPPSPLINTE - GOUPILLES CLIPS

Cod.	Ø mm
STO 099 D045	4,5
STO 099 D06	6
STO 099 D07	7
STO 099 D08	8

Cod.	Ø mm
STO 099 D09	9
STO 099 D10	10
STO 099 D11	11



EuroSnodi

Agricultural Division

42100 Reggio Emilia (Italy)
Zona Industriale Mancasale - Via Bernini, 2
Tel. +39-0522.271652 - Fax +39-0522.271668
www.eurosnodi.it - E-mail: info@eurosnodi.it

