

OMP/OMR系列摆线液压马达

OMP/OMR Series Hydraulic Orbit Motor



■ 特点 Feature:

OMR是一种轴配流式马达

采用镶针齿定转子副设计，启动压力低，效率优于BMP马达。

可靠的轴密封设计，承受背压高，可以串并联使用。

正反换转向方便、转速平稳。

OMR Motor is one spool valve type motor,

Advanced manufacturing devices for the geroler gear set, the efficiency is better than OMP motor.

Shaft seal can bear high pressure of back and the motor can be used in parallel or in series.



■ OMP/OMR型号说明 Model Code

OMP	-125	S	A1	P3	Y10
系列 Code	排量 Displacement	油口类型 Port Type	安装法兰及止口 Mounting Flange&Spigot	输出轴 Shaft	油口&泄油口 Inlet&Outlet and Drain
OMP OMR	40,50,63,80,100, 125,160,200,250, 315,400,500	S: S Type H: H Type L: L Type	参照下图 See Below Drawing		
OMRW	-160	A		Z	Y
系列 Code	排量 Displacement	安装法兰及止口 Mounting Flange&Spigot		输出轴 Shaft	油口&泄油口 Inlet&Outlet and Drain
OMRW OMRW1	40,50,80,100,125,160, 200,250,315,400	A: 4-φ13.5方形法兰 Square Flange, 止口 Poiltφ82.5x9		参照下图 See Below Drawing	

■ OMR技术参数 Technical Data

型号 Type	OMP OMRW 50	OMP OMRW 80	OMP OMRW 100	OMP OMRW 125	OMP OMRW 160	OMP OMRW 200	OMP OMRW 250	OMP OMRW 315	OMP OMRW 400
排量 Displacement.(ml/r)	51.7	80.5	100.5	126.3	160.8	200.9	252.6	321.5	401.9
最大压降 Max.Pressure. Drop (Mpa)	连续 cont.	14	14	14	14	14	11	9	7
	间断 int.	17.5	17.5	17.5	17.5	17.5	14	11	9
	尖峰 peak.	20	20	20	20	20	16	13	11
最大扭矩 Max.torque (Nm)	连续 cont.	93	152	194	237	310	369	380	380
	间断 int.	118	189	236	296	378	450	470	470
	尖峰 peak.	135	216	270	338	433	509	540	540
转速范围(连续) Speed.Range(cont.)(r/min)	10-775	10-750	10-600	10-475	10-375	10-300	10-240	10-190	10-160
最大流量(连续) Max.Flow(cont.)(L/min)	40	60	60	60	60	60	60	60	60
最大输出功率(连续)(Kw) Max.Output.Power(cont.)	7	10	10	10	10	8	6	5	4
重量 Weight(Kg)	6.5	6.9	7.0	7.3	7.5	8.0	8.5	9.0	11

间断工作时间每分钟不得超过6秒，尖峰工作时间每分钟不得超过0.6秒。

Intermittent operation the permissible values may occur for max.10% of every minute,

Peak load:the permissible values may occur for max.1% of every minute.

轴承受最大扭矩 (N.m) : Φ25, Φ25.4花键轴为360, Φ25, Φ25.4平键轴为300。

OMP/OMR马达连接尺寸&外形图 Dimension&Mounting

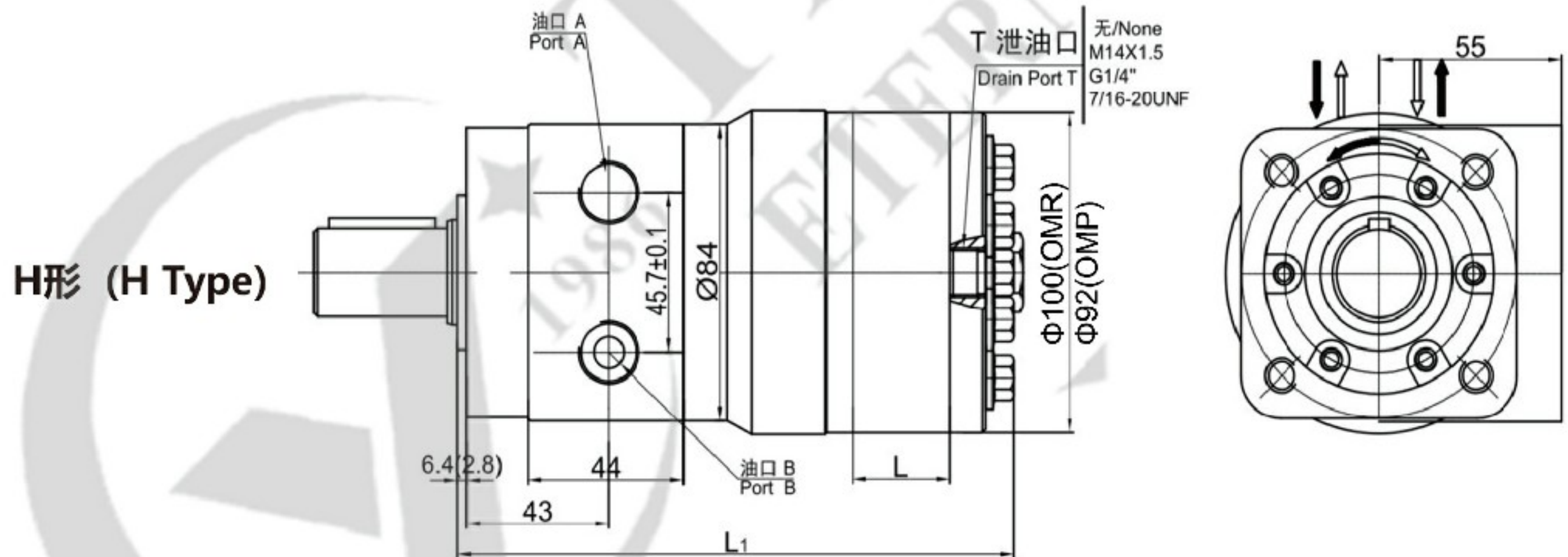
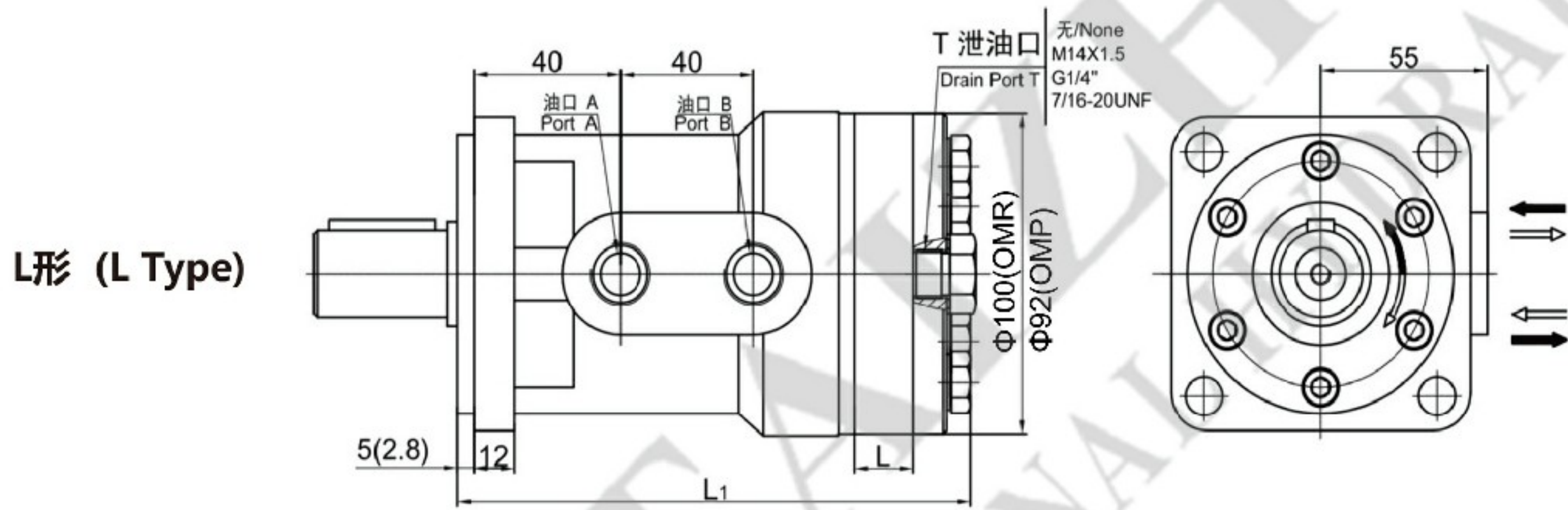
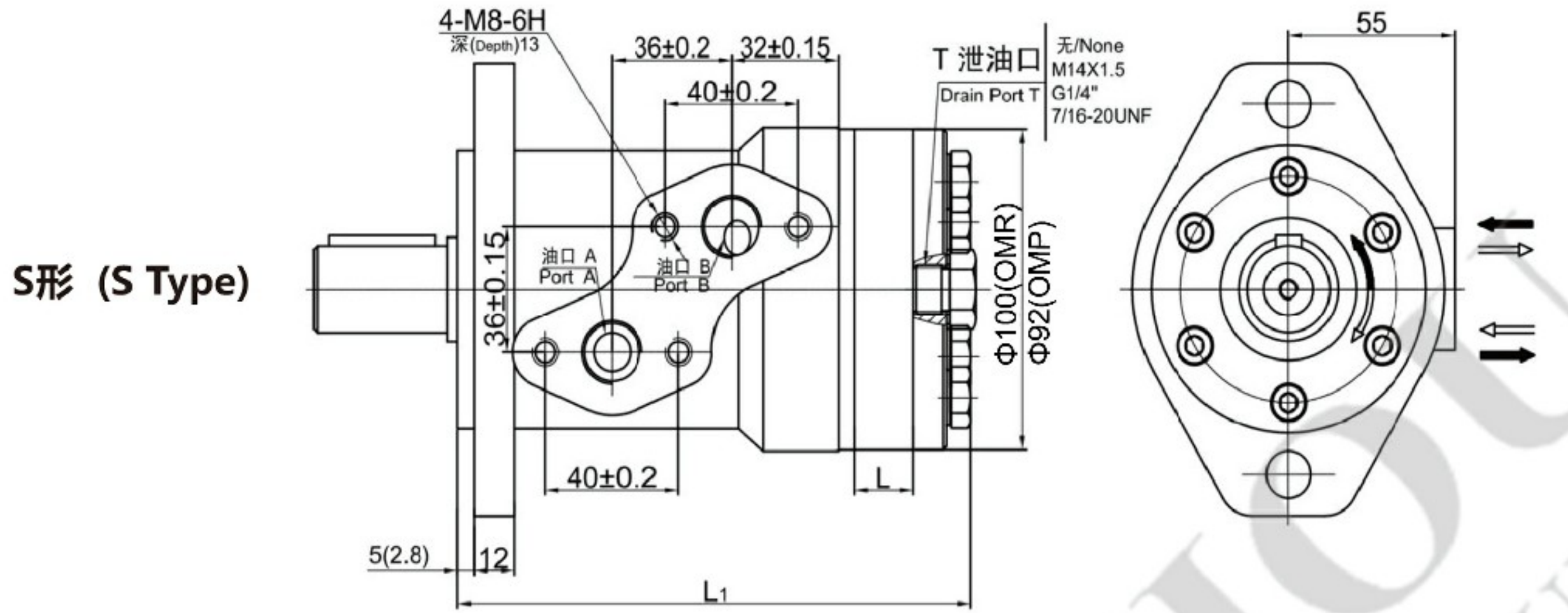

输出轴负载能力 Shaft Load Capacity:
径向负载 Radial Load: 400Kg Max.
轴向负载 Axis Load: 200Kg Max.

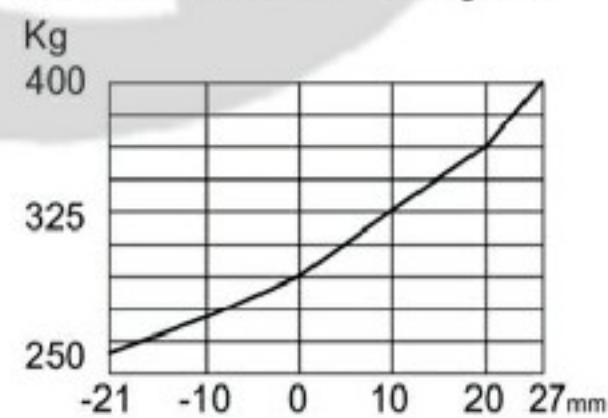

排量 Displacement	50	63	80	100	125	160	200	250	315	400
L	9	11.5	14.5	18	22.5	28.8	37	44.6	55	72
L ₁	147	149.5	152.5	156	160.5	168.8	175	182.6	193	210

马达标准旋向:

面对输出轴轴端, A油口进油, 马达顺时针旋转。
Standard Direction of The Motor Rotation:
CW----When A Port pressurized, Viewed From the Shaft End.

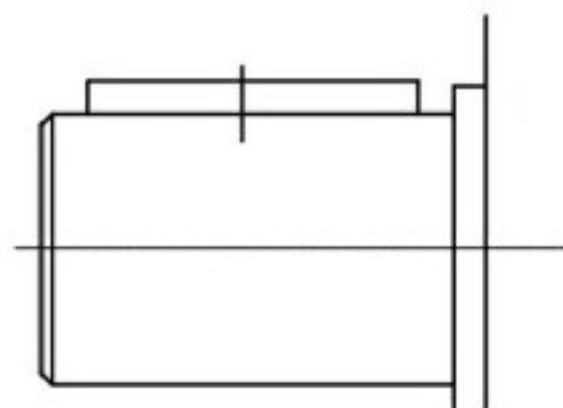

■ OMP/OMR 马达安装法兰 Mounting Flange

A1法兰
Flange A1

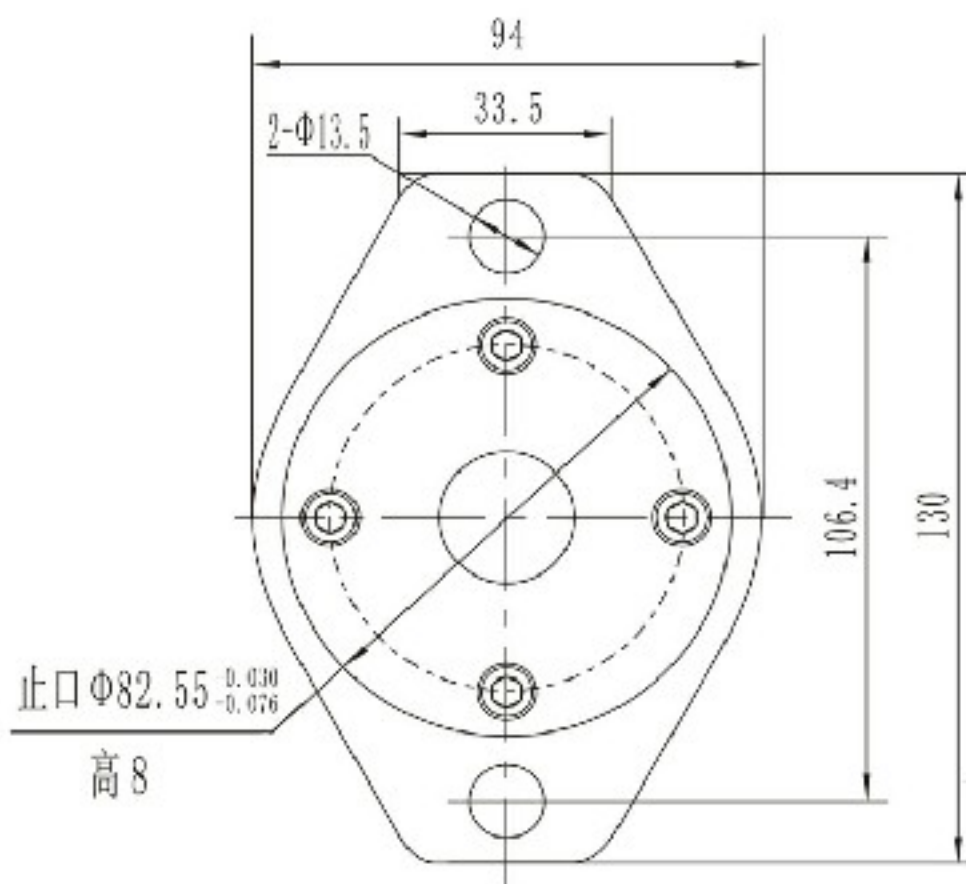

A2法兰
Flange A2

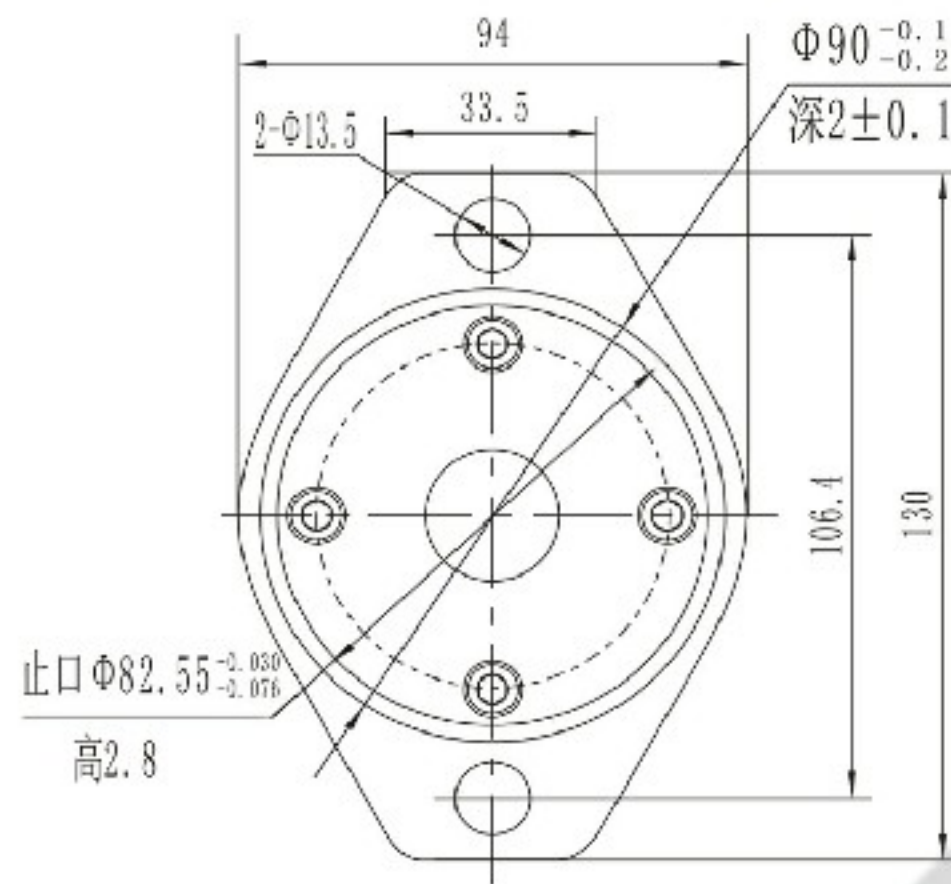

A3法兰
Flange A3

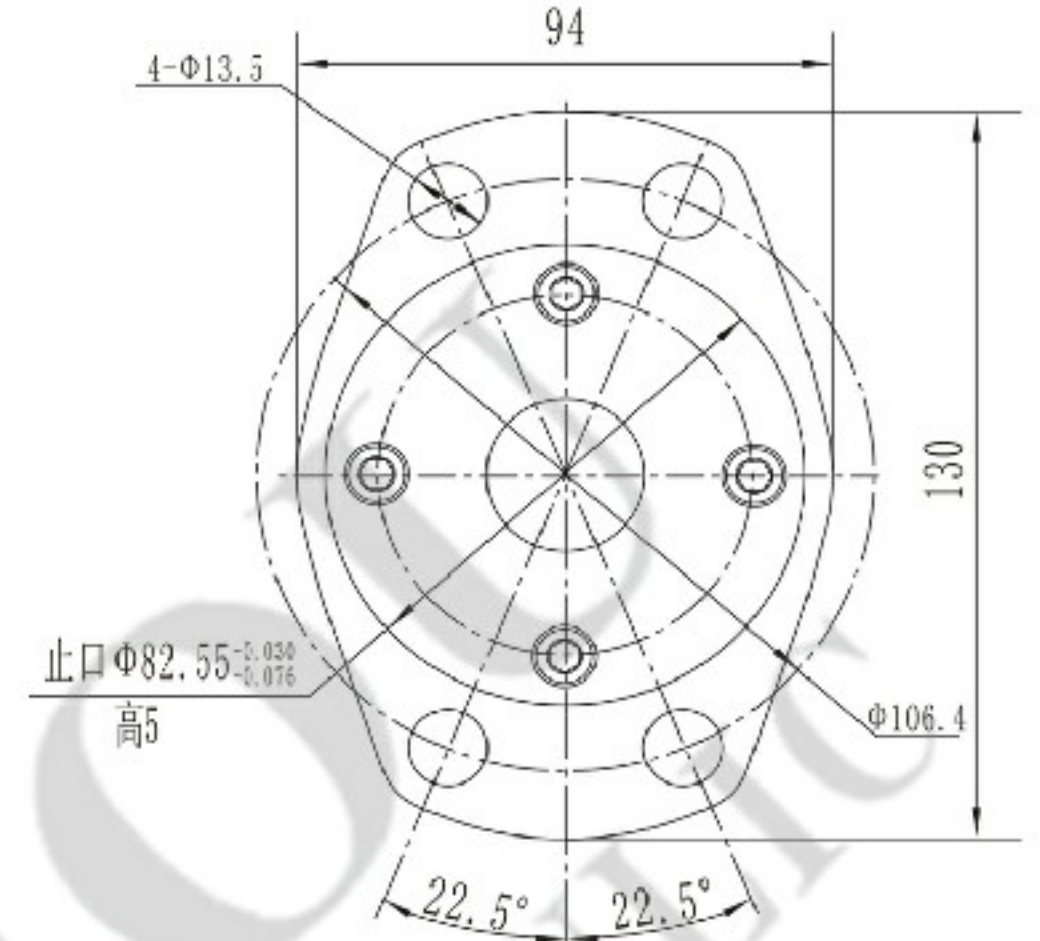

B1法兰
Flange B1

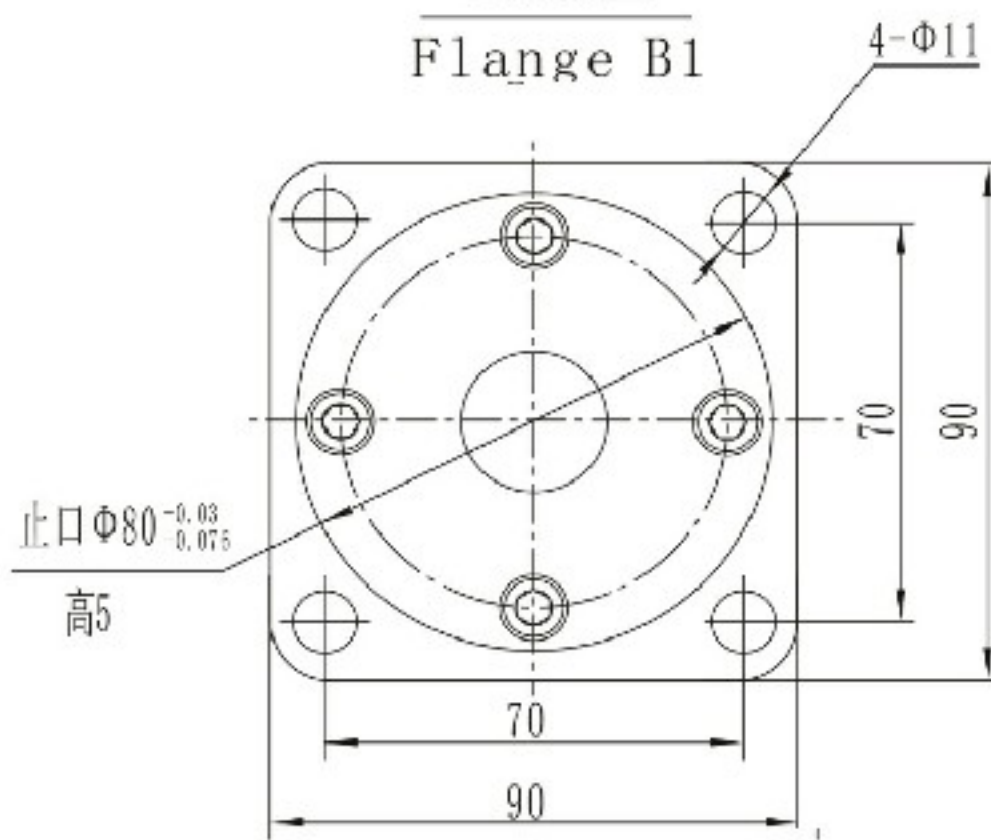

B2法兰
Flange B2

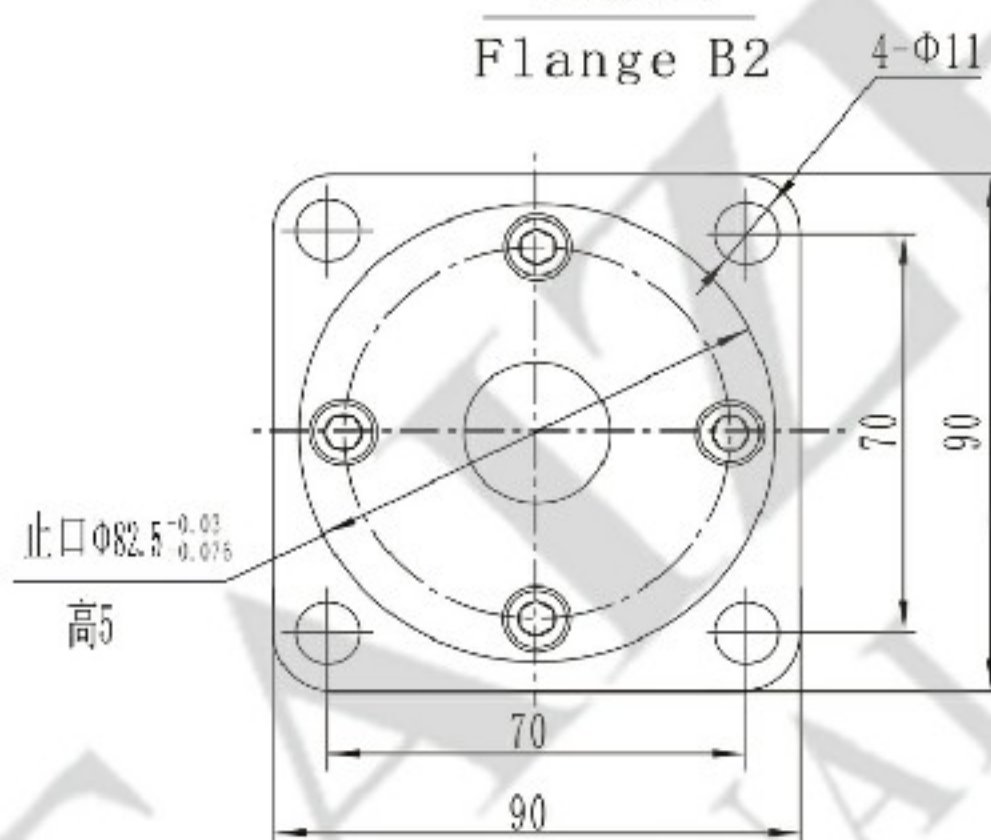

B3&B4法兰
Flange B3&B4

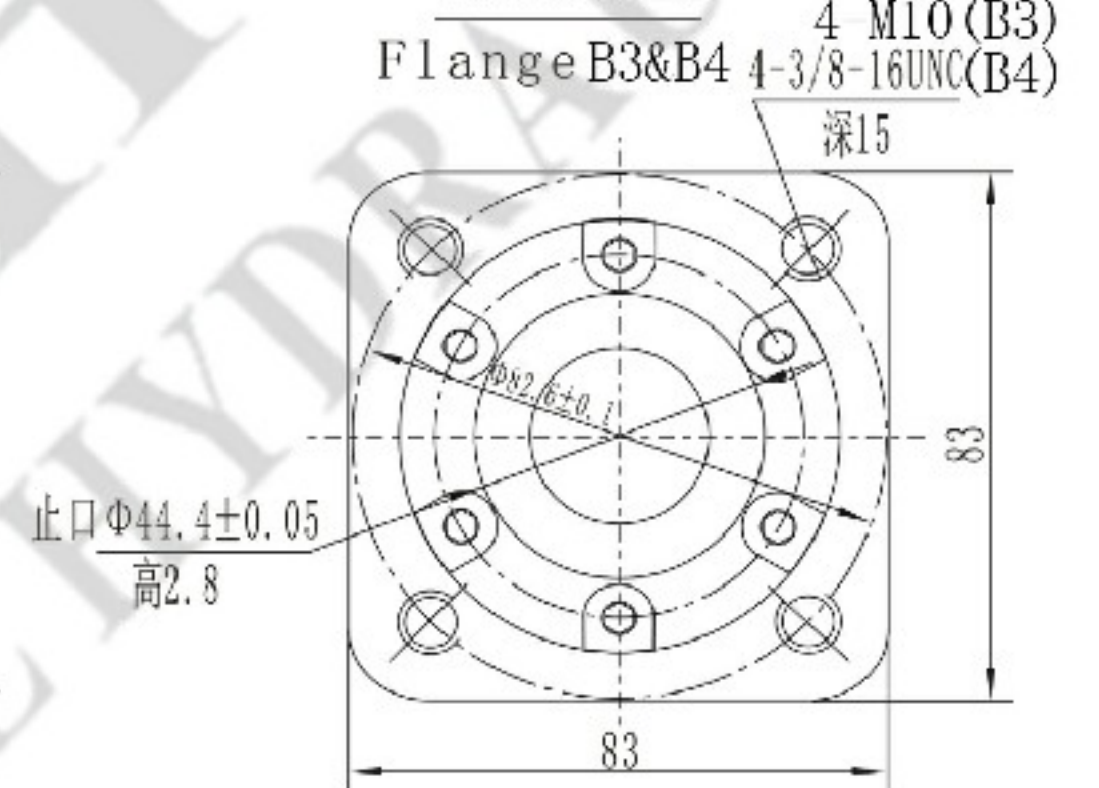

C1法兰
Flange C1

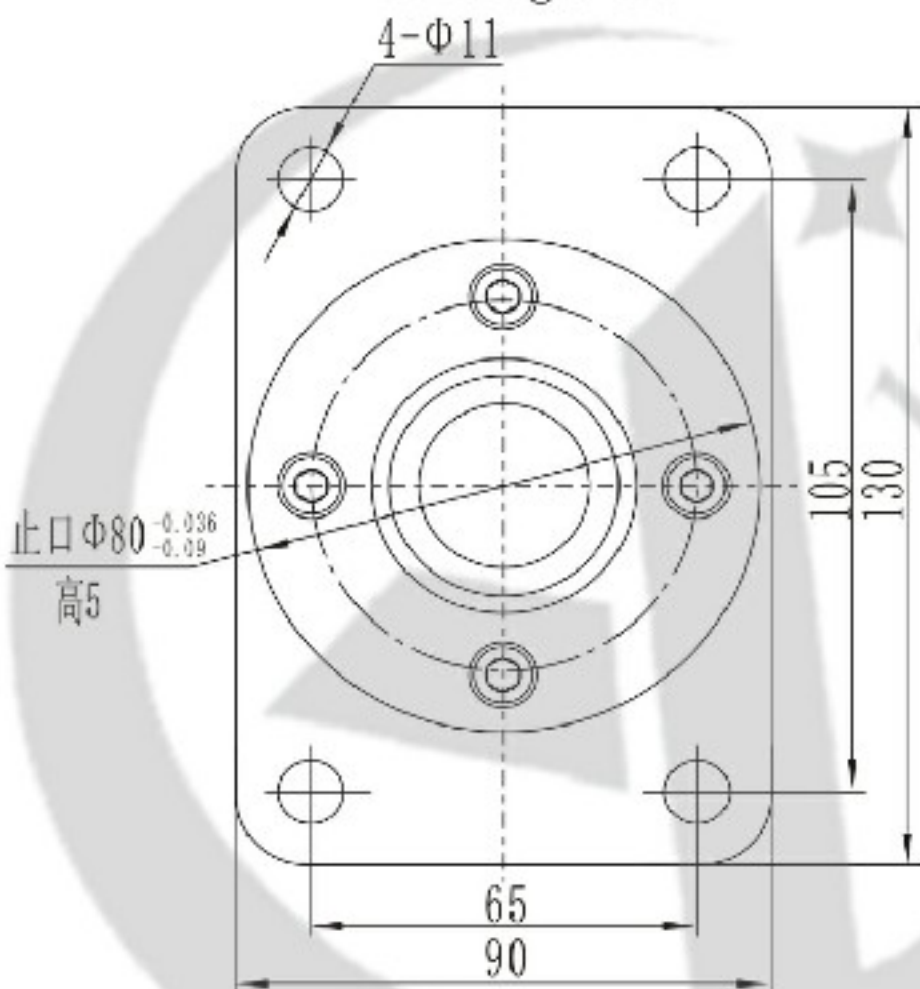

C2法兰
Flange C2

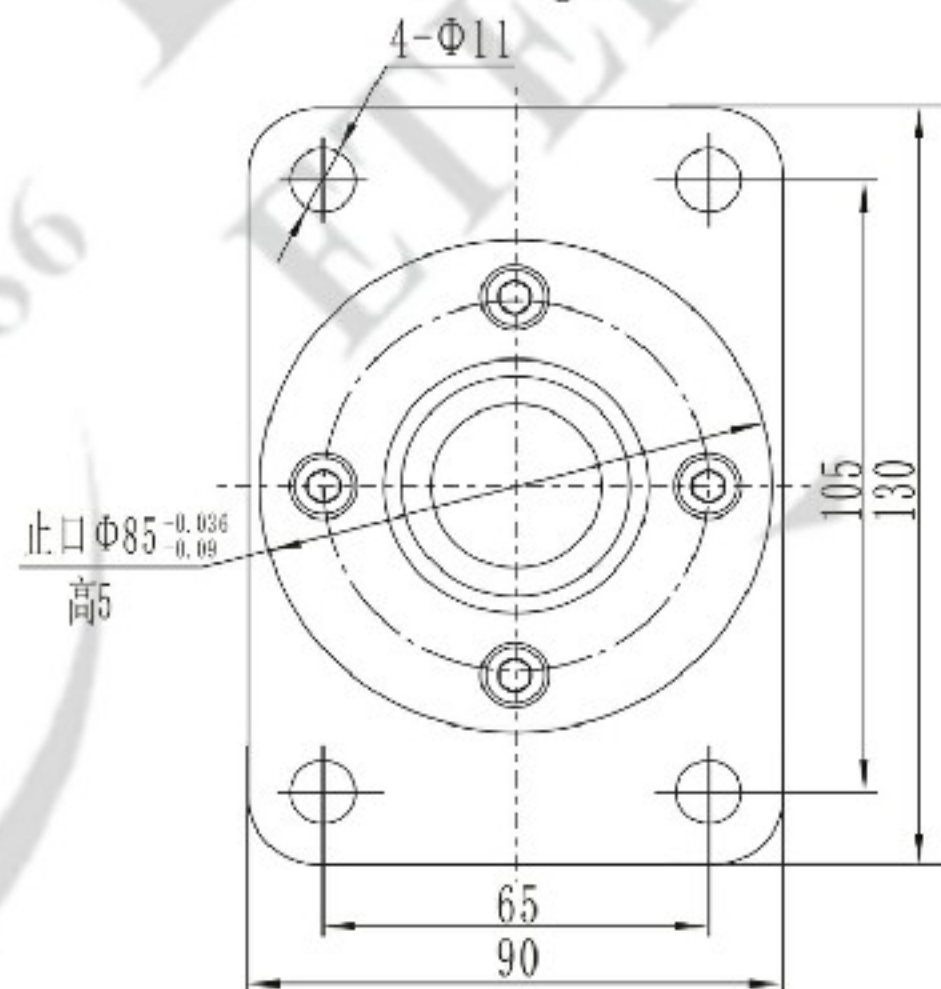

B5法兰
Flange B5

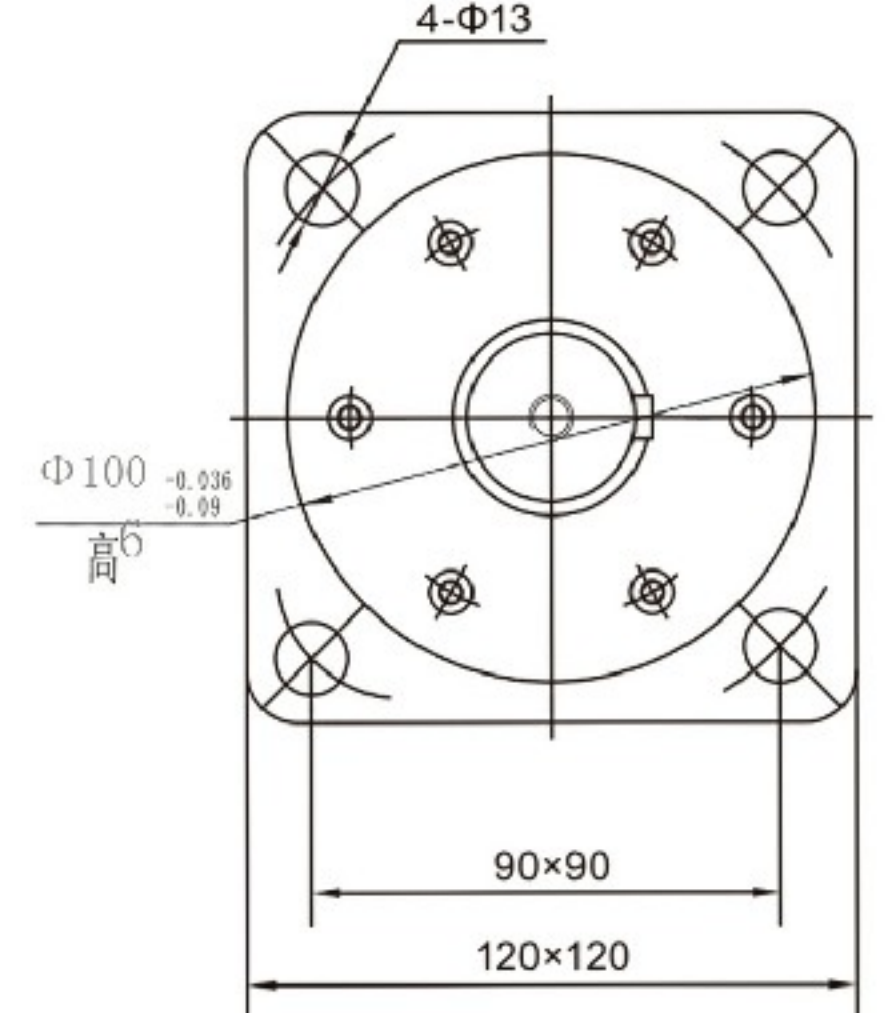

OMP/OMR油口代号 Port Code

油口 Ports 代号 Code	P(A、B)(深deep)	C (深deep)	T (深deep)
Y	G1/2 (15)	M8 (13)	M14 × 1.5 (12)
Y1	M18 × 1.5 (15)	M8 (13)	M14 × 1.5 (12)
Y2	M22 × 1.5 (15)	M8 (13)	M14 × 1.5 (12)
Y4	ZG3/8 (15)	M8 (13)	M14 × 1.5 (12)
Y5	7/8-14UNF (15)	—	M14 × 1.5 (12)
Y7	ZG1/2 (15)	M8 (13)	M14 × 1.5 (12)
Y8	NPT1/2 (15)	M8 (13)	M14 × 1.5 (12)
Y9	NPTF1/2 (15)	5/16-18UNC (13)	7/16-20UNF (12)
Y10	G1/2 (15)	M8 (13)	G1/4 (12)
Y15	7/8-14UNF (15)	5/16-18UNC (13)	7/16-20UNF (12)
Y17	3/4-16UNF(15)	—	7/16-20UNF(12)
Y19	Φ11(15)	5/16-18UNC(13)	7/16-20UNF(12)
Y20	M18 × 1.5(15)	M8 (13)	G1/4(12)

注: P(A、B)--进出油口, C--油口面安装螺纹 (—表示没有此螺纹孔), T--泄油口

Note:P(A、B)--Ports, C--Mounting Thread (—Indicates no this thread), T--Drain connettion

OMP/OMR外形安装尺寸—输出轴 Shaft Version

P1: Φ25平键轴, 平键8 × 7 × 32

Φ25 Cylindrical shaft, parallel key 8 × 7 × 32

P2: Φ30平键轴, 平键8 × 7 × 32

Φ30 Cylindrical shaft, parallel key 8 × 7 × 32

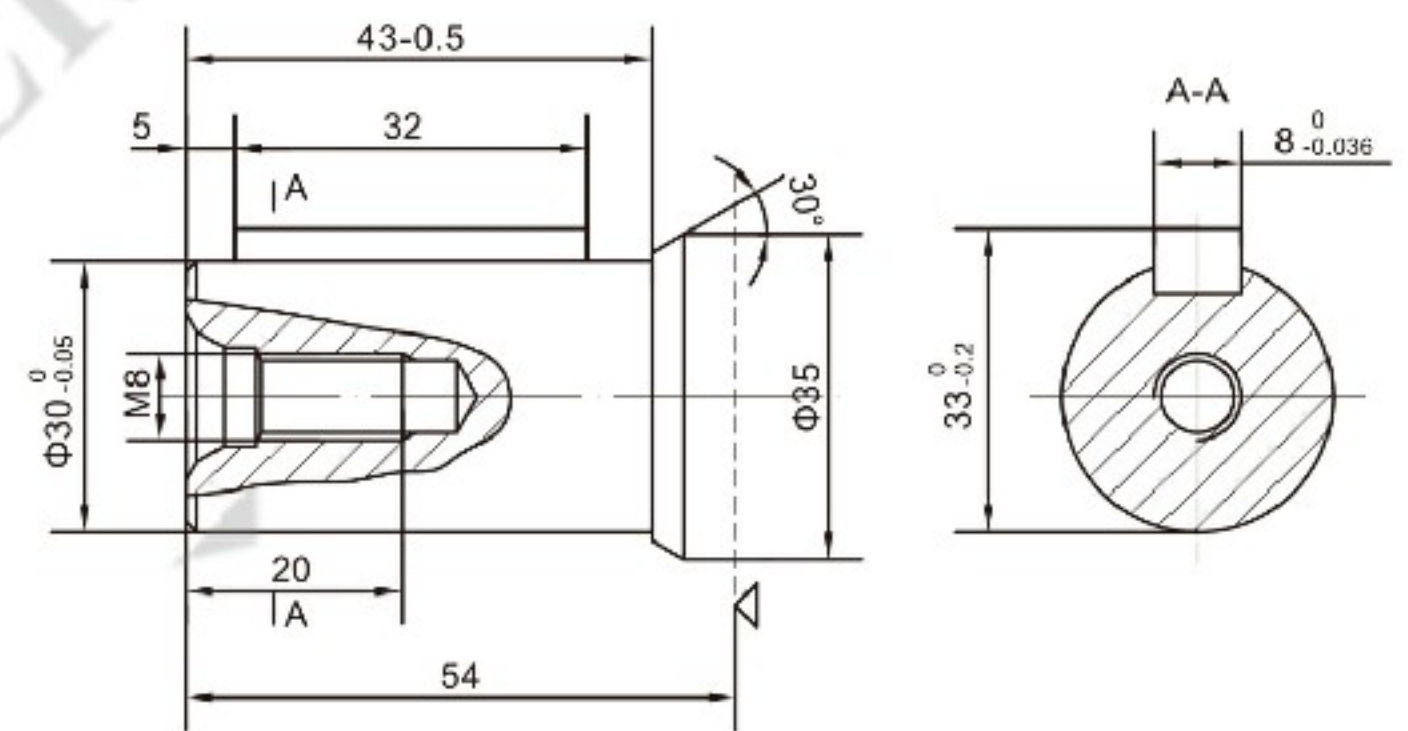
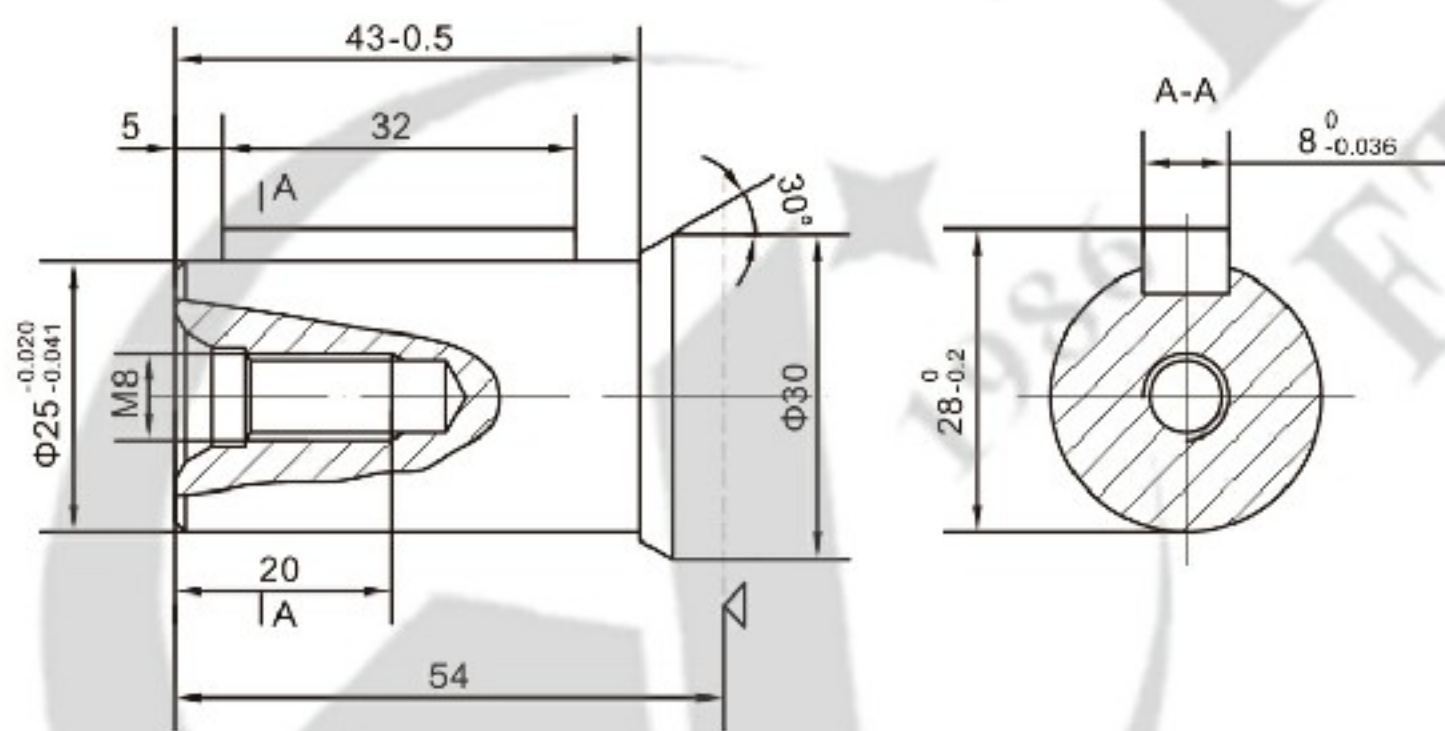

P3: Φ25.4平键轴, 平键6.35 × 6.35 × 32

Φ25.4 Cylindrical shaft, parallel key 6.35 × 6.35 × 32

P4: Φ25.4平键轴, 半圆键Φ25.4 × 6.35

Φ25.4 Cylindrical shaft, Woodruff key Φ25.4 × 6.35

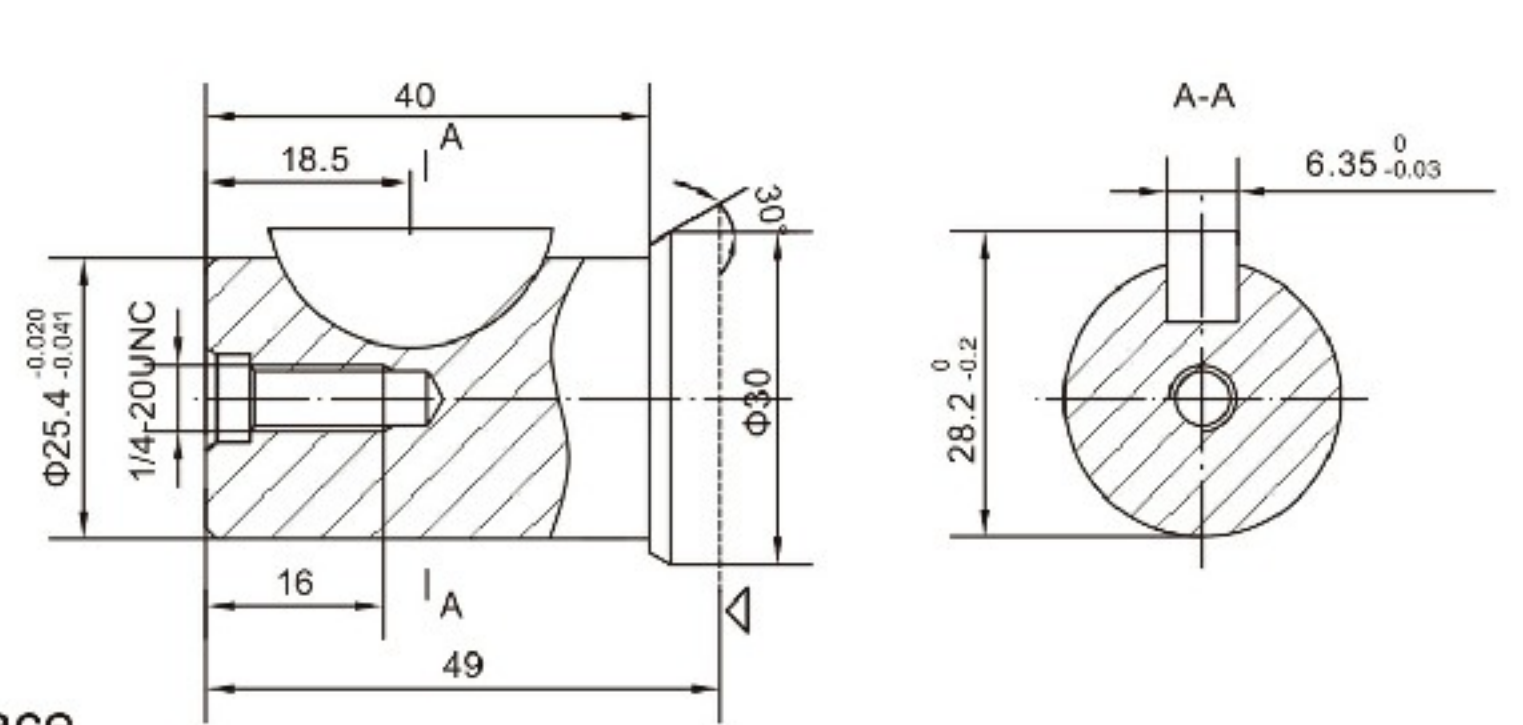
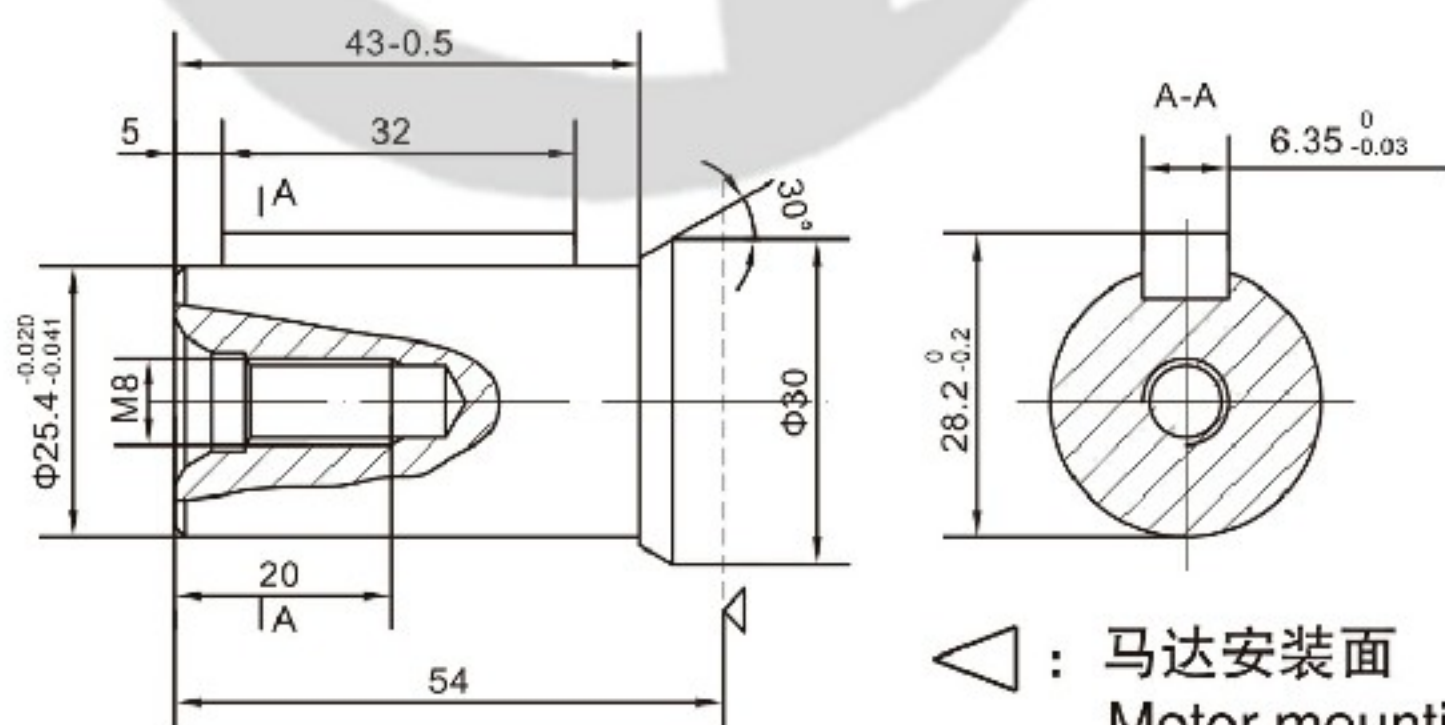

△ : 马达安装面
Motor mounting surface

OMP/OMR外形安装尺寸—输出轴 Shaft Version

P5&P52: $\Phi 32$ 平键轴, 平键 $10 \times 8 \times 45$
 $\Phi 32$ Cylindrical shaft, parallel key $10 \times 8 \times 45$

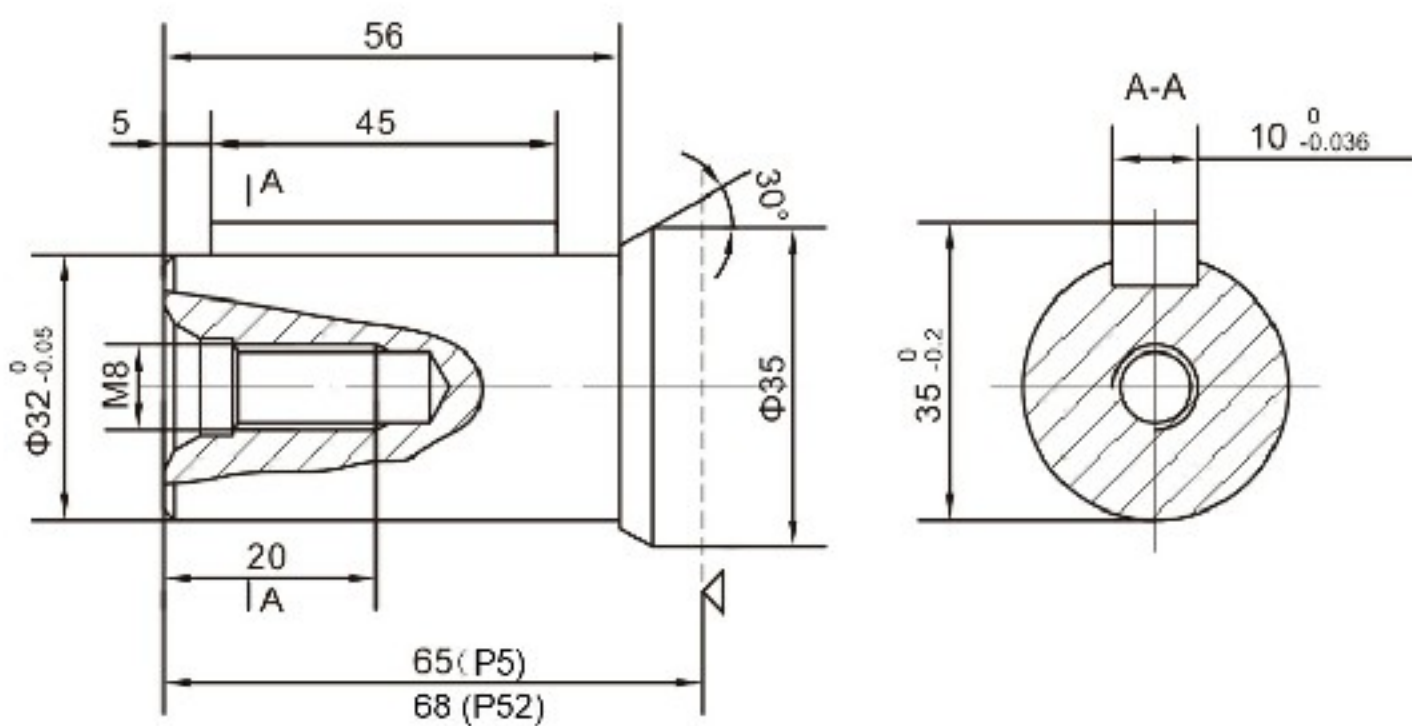

P6: $\Phi 31.75$ 平键轴, 平键 $7.96 \times 7.96 \times 32$
 $\Phi 31.75$ Cylindrical shaft, parallel key $7.96 \times 7.96 \times 32$

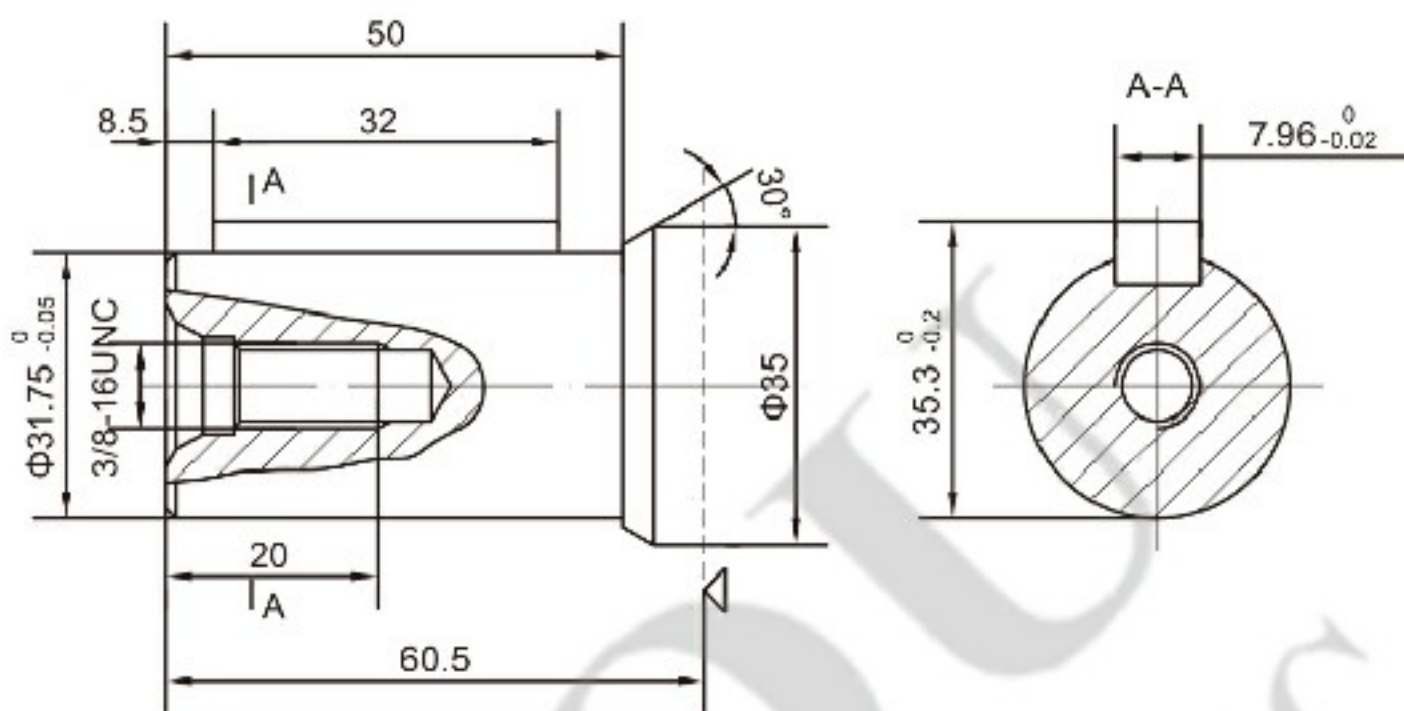

H1: $\Phi 30$ 矩形花键轴, $6-30 \times 25 \times 6$
 $\Phi 30$ Splined shaft, $6-30 \times 25 \times 6$

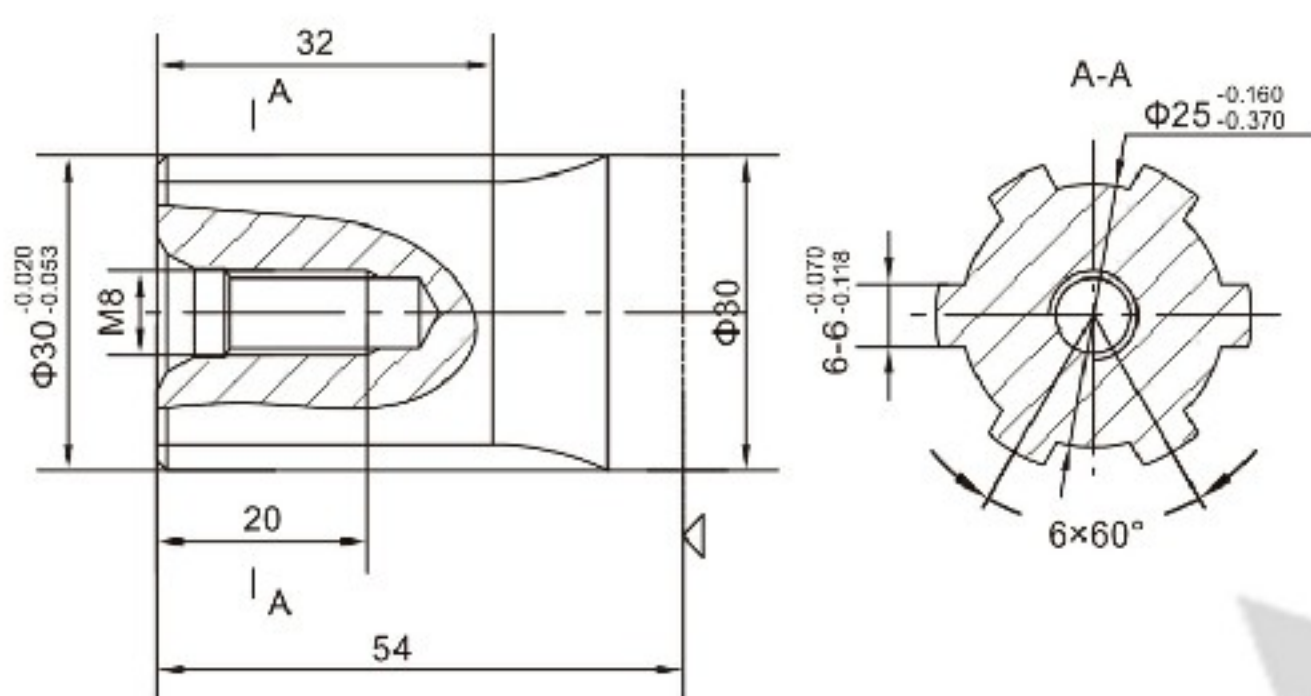

H2: $\Phi 25$ 矩形花键轴, $6-25 \times 21 \times 5$
 $\Phi 25$ Splined shaft, $6-25 \times 21 \times 5$

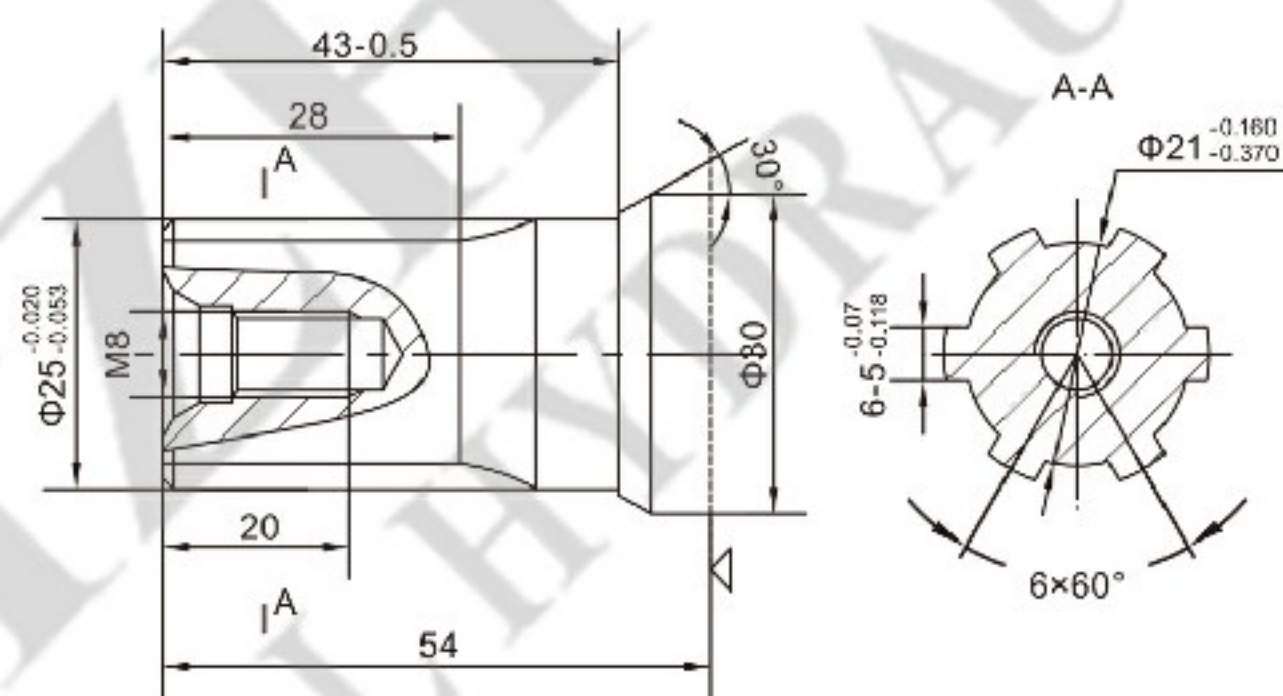

H3: $\Phi 25.3$ 矩形花键轴, $6-25.3 \times 21.4 \times 6.2$
 $\Phi 25.3$ Splined shaft, $6-25.3 \times 21.4 \times 6.2$

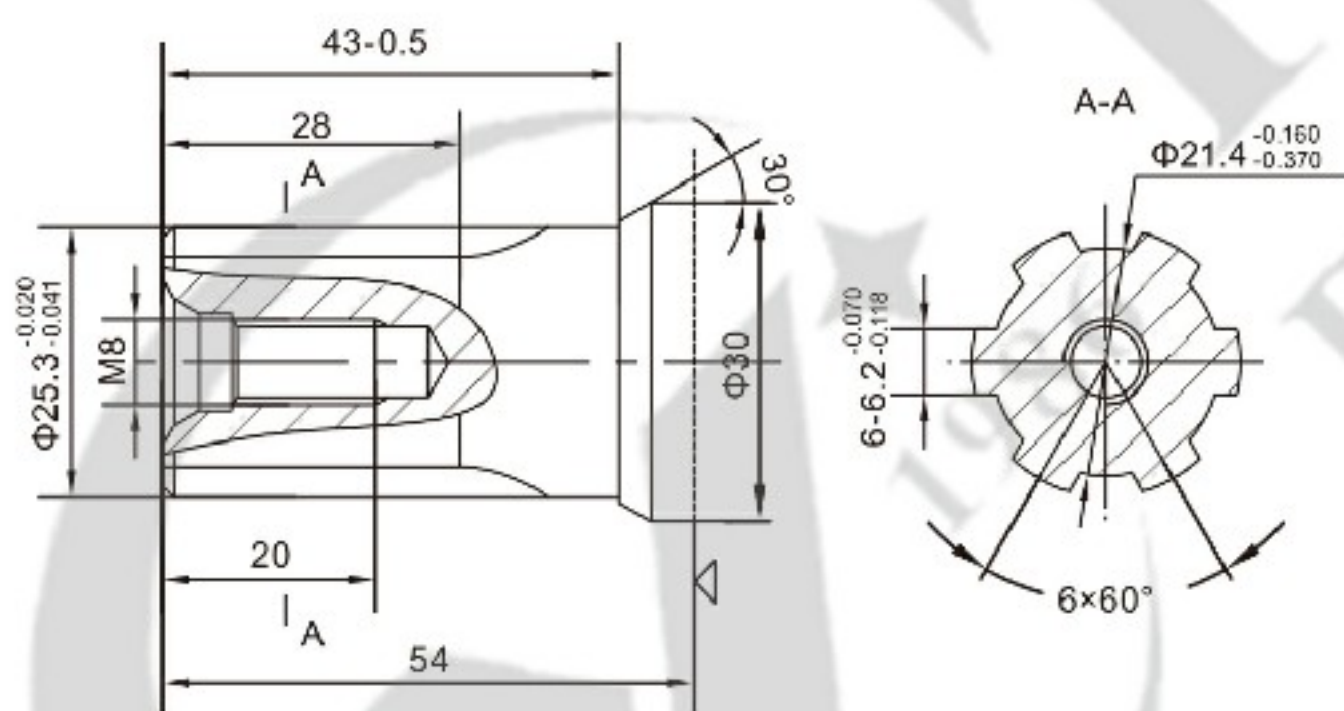

Z1: $\Phi 28.56$ 锥轴, 锥度 $1:10$, 平键 $5 \times 5 \times 14$
 $\Phi 28.56$ Tapered shaft, taper $1:10$, parallel key $5 \times 5 \times 14$

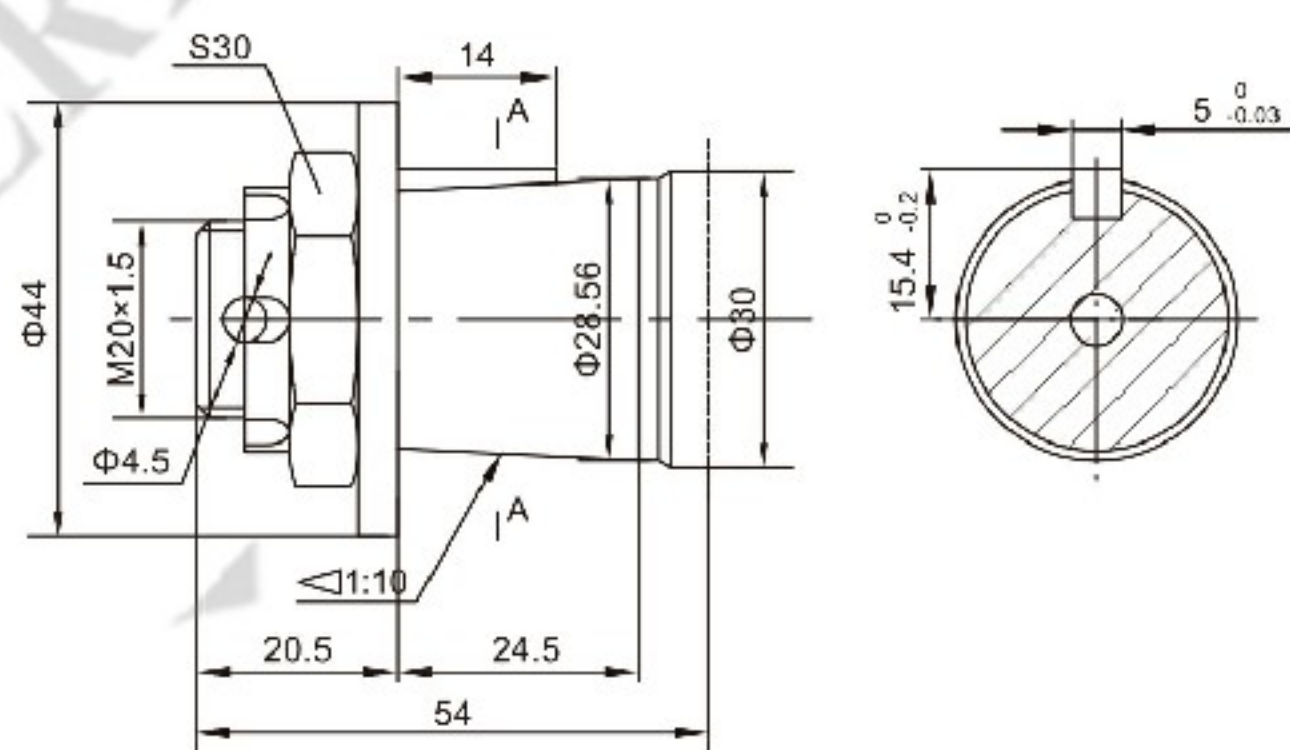

F&FD: $\Phi 31.75$ 渐开线花键轴 $14-DP12/24$
 $\Phi 31.75$ involute splined shaft $14-DP12/24$

K10: $\Phi 31.75$ 渐开线花键轴 $14-DP12/24$ $a=30^\circ$
 $\Phi 31.75$ involute splined shaft $14-DP12/24$ $a=30^\circ$

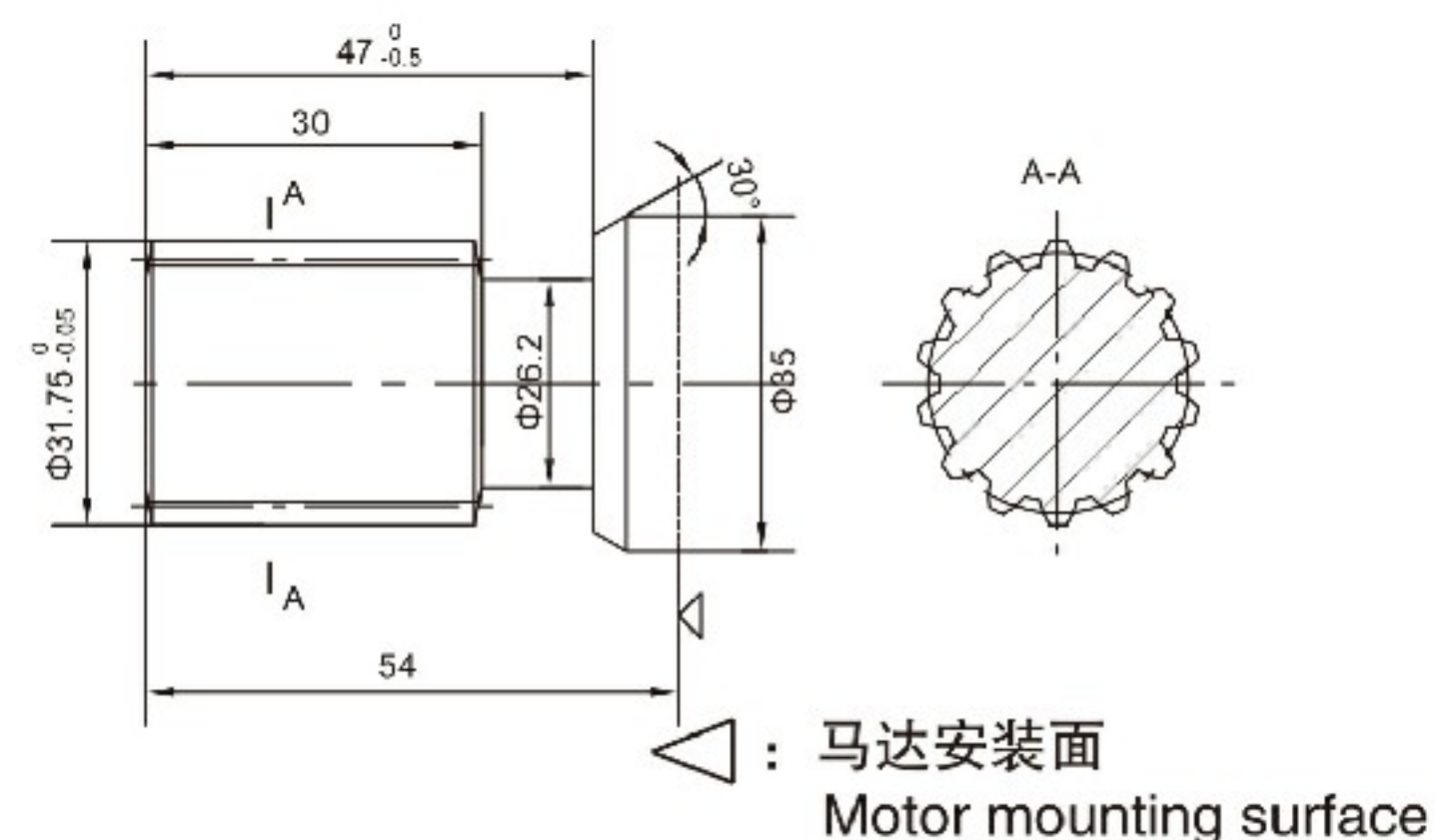
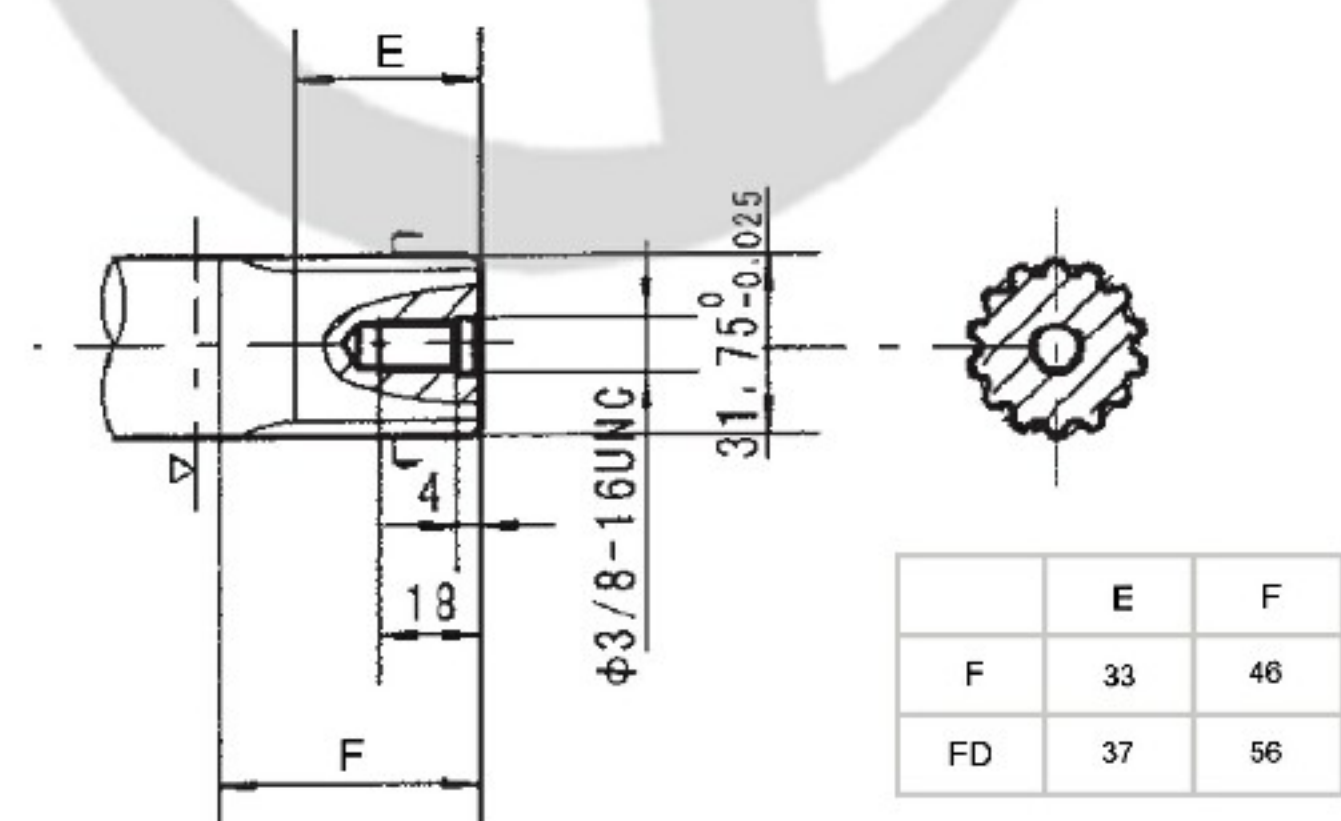

■ OMRW轮用马达外形安装图 Installation

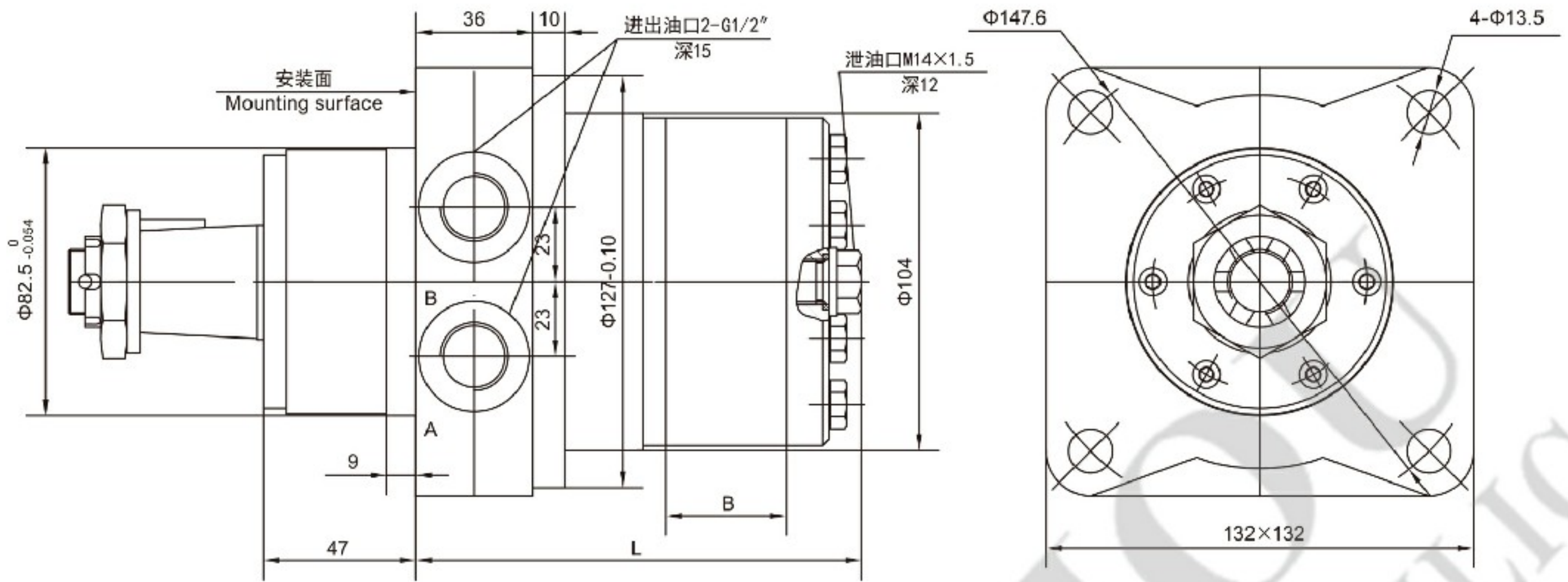

型号Type	BMRW-50	BMRW-80	BMRW-100	BMRW-125	BMRW-160	BMRW-200	BMRW-250	BMRW-315	BMRW-400
L	108	113	117	121	127	134	143	155	169
B	9	14	17.5	22	28	35	44	56	70

■ OMRW油口代号 Port Code

油口 Ports	P(A、B)(深deep)	C (深deep)	T (深deep)
代号 Code			
Y	G1/2 (15)	—	M14 × 1.5(12)

P(A、B)—进出油口，C—油口面安装螺纹孔（—表示没有此螺纹孔），T—泄油口
P(A、B)—Ports, C—Mounting Thread（—Indicates no this thread），T—Drain connettion

■ OMRW轮用马达外形连接尺寸—输出轴 Shaft Version

Z: Φ35锥轴, 锥度1:10, 平键B6 × 6 × 20
Φ35 Tapered shaft, taper1:10, parallel key B6 × 6 × 20

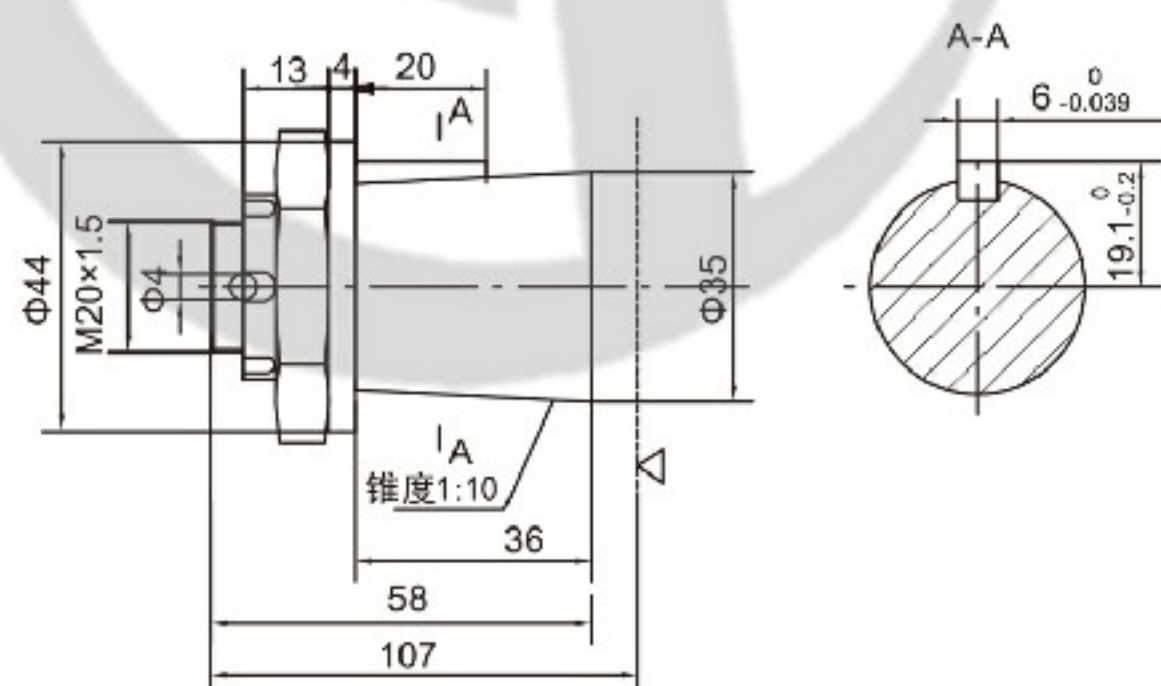

△: 马达安装面
Motor mounting surface

■ OMRW1轮用马达外形安装图 Installation

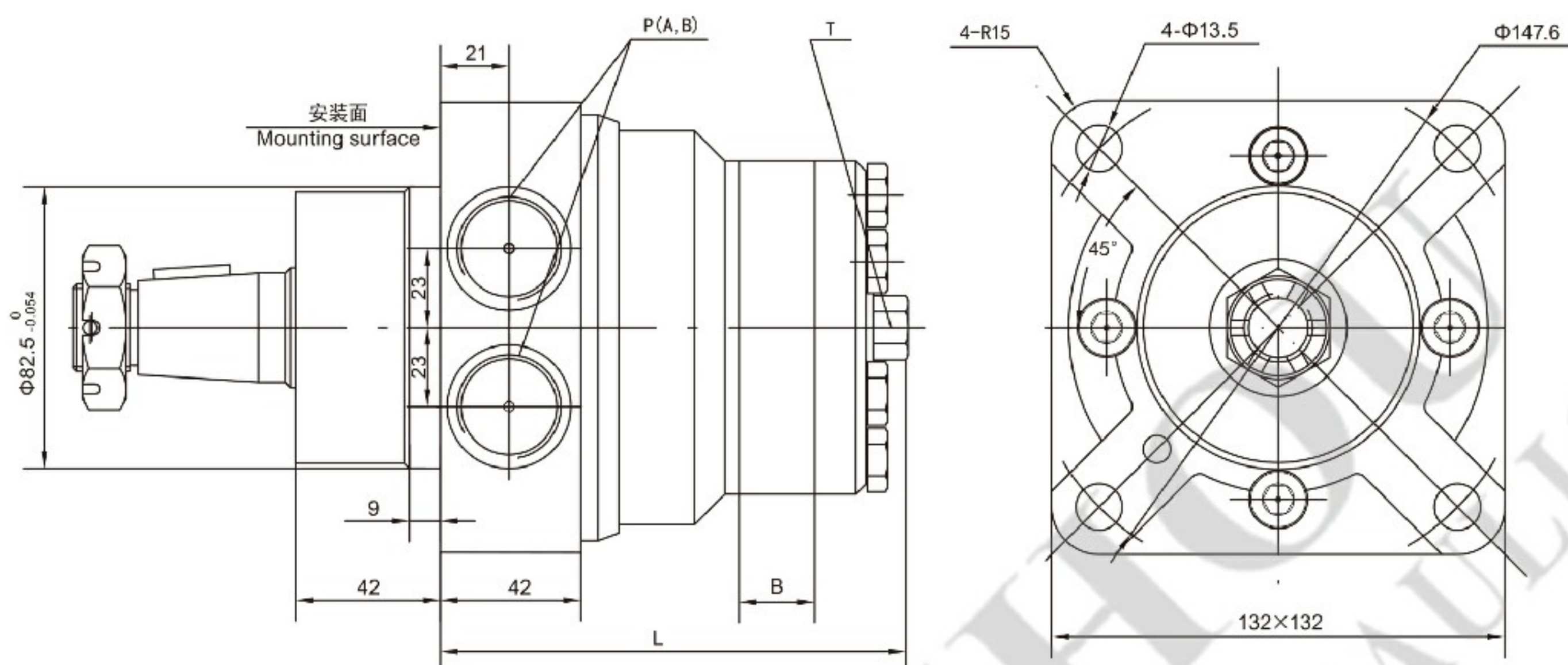

型号 Type	OMRW1-50	OMRW1-80	OMRW1-100	OMRW1-125	OMRW1-160	OMRW1-200	OMRW1-250	OMRW1-315	OMRW1-400
L	125	130	134	138	144	151	160	172	186
B	9	14	17.5	22	28	35	44	56	70

■ OMRW1油口代号 Port Code

油口 Ports 代号 Code	P(A、B)(深deep)	C (深deep)	T (深deep)
Y	G1/2 (15)	—	M14 × 1.5(12)
Y5	7/8-14UNF(15)	—	M14 × 1.5(12)
Y10	G1/2 (15)	—	G1/4 (12)

P(A、B)—进出油口，C—油口面安装螺纹孔（—表示没有此螺纹孔），T—泄油口

P(A、B)—Ports, C—Mounting Thread（—Indicates no this thread），T—Drain connettion

■ OMRW轮用马达输出轴 Shaft Version

P1: $\Phi 25$ 平键轴, 平键 $8 \times 7 \times 45$
 $\Phi 25$ Cylindrical shaft, Parallel key $8 \times 7 \times 45$

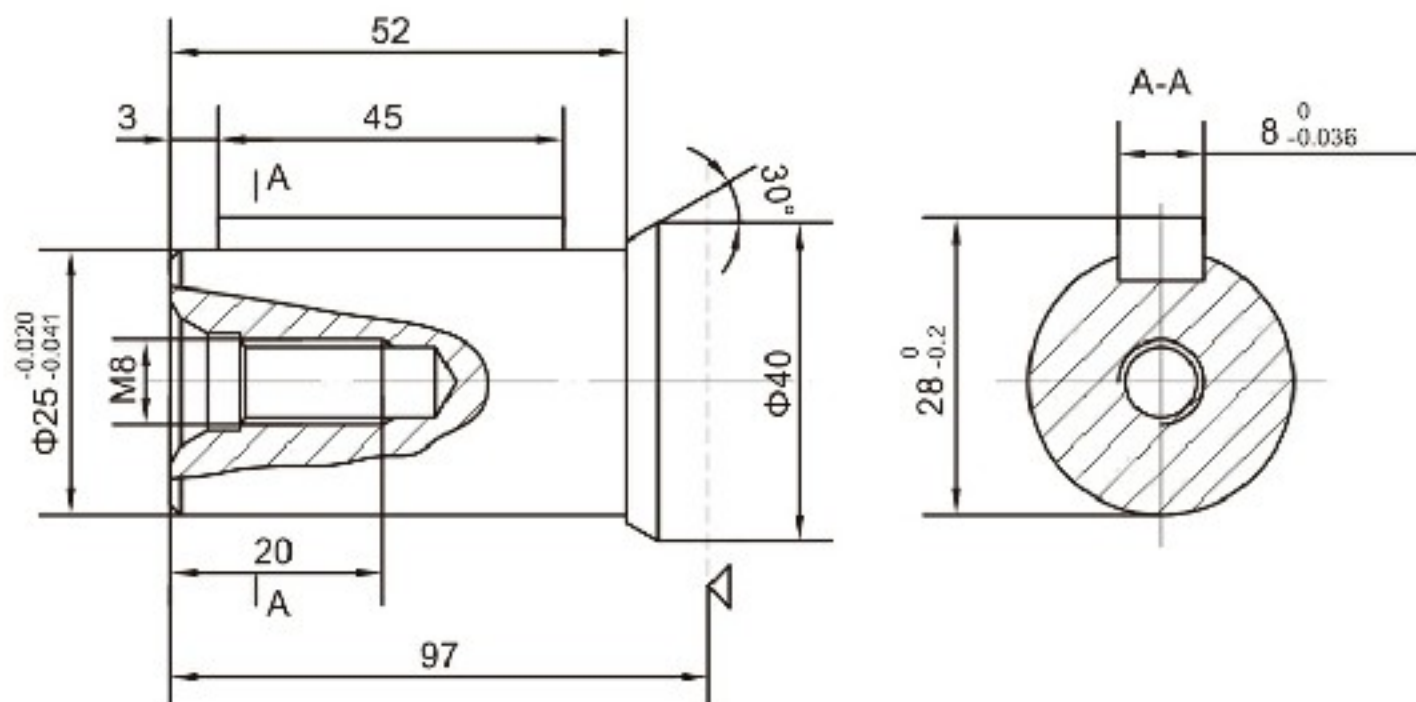

P5: $\Phi 32$ 平键轴, 平键 $10 \times 8 \times 45$
 $\Phi 32$ Cylindrical shaft, parallel key $10 \times 8 \times 45$

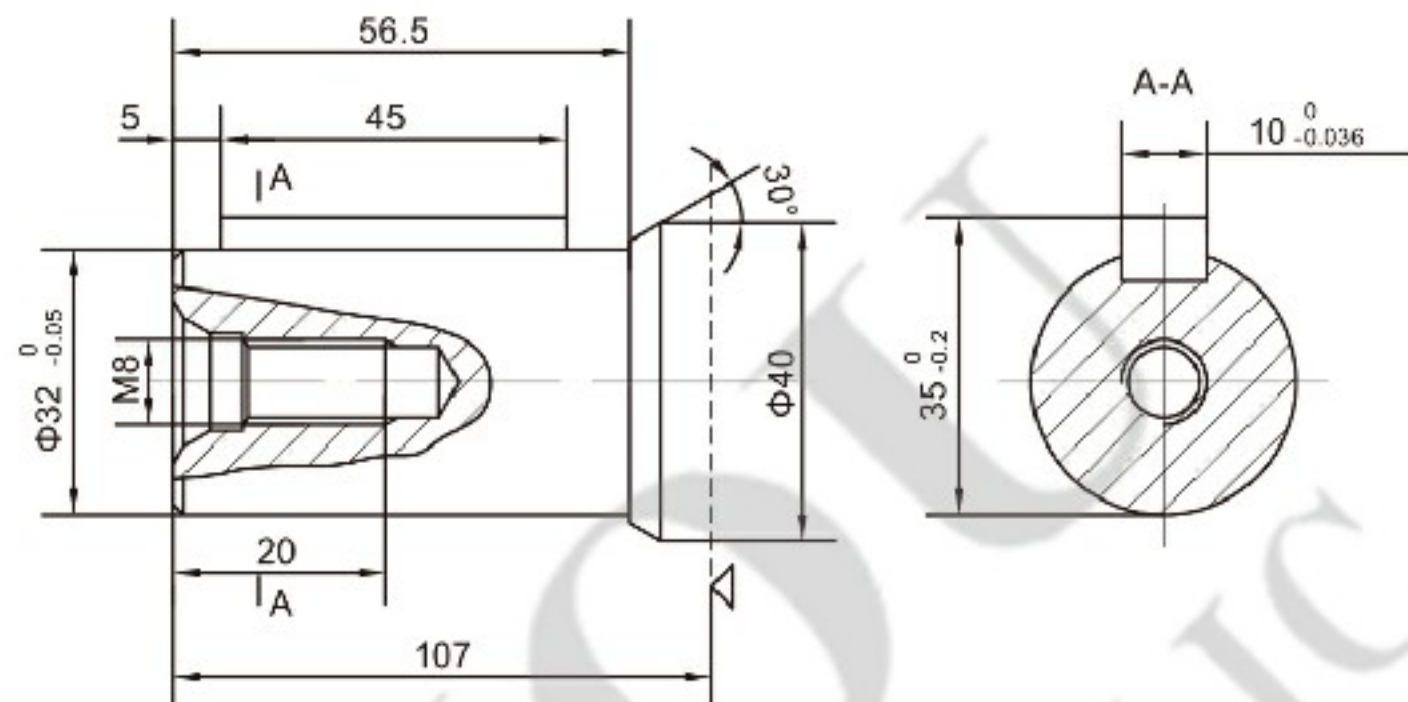

P6: $\Phi 32$ 平键轴, 距轴端30处 $\Phi 8.1$ 通孔, 平键 $10 \times 8 \times 45$
 $\Phi 32$ Cylindrical shaft, Cylindrical shaft pin hole $\Phi 8.1$, parallel key $10 \times 8 \times 45$

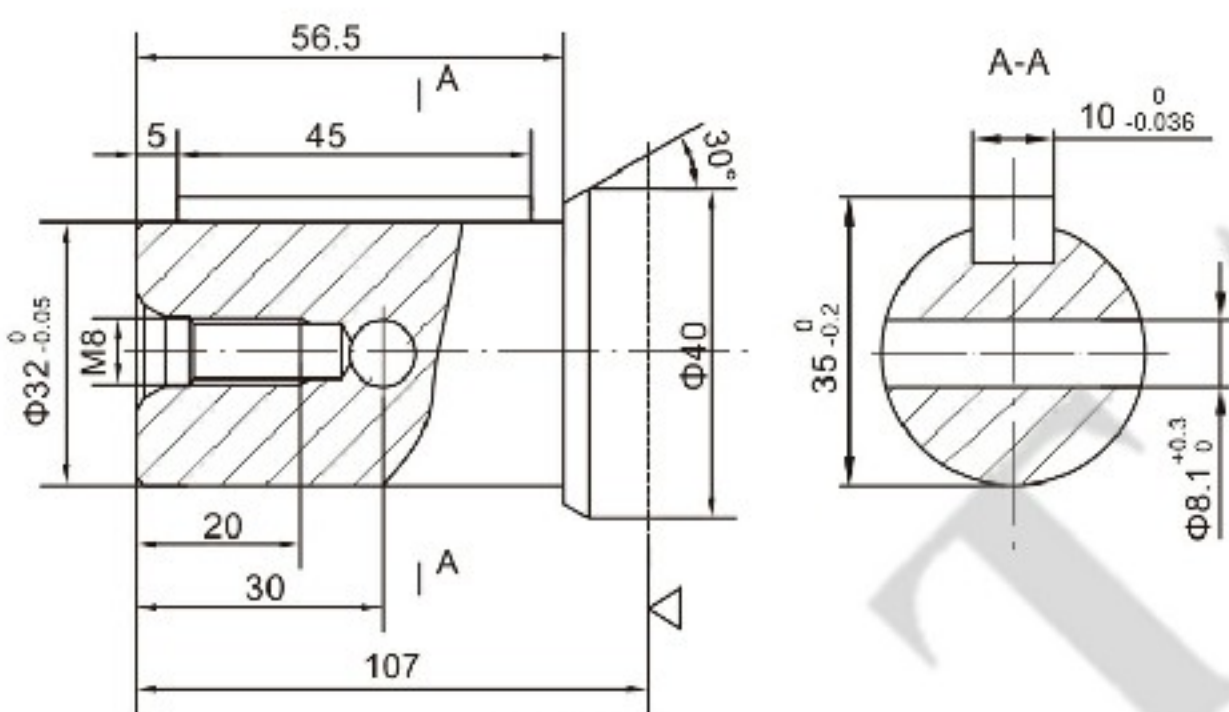

Z: $\Phi 35$ 锥轴, 锥度1:10, 平键 $B6 \times 6 \times 20$
 $\Phi 35$ Tapered shaft, taper 1:10, parallel key $B6 \times 6 \times 20$

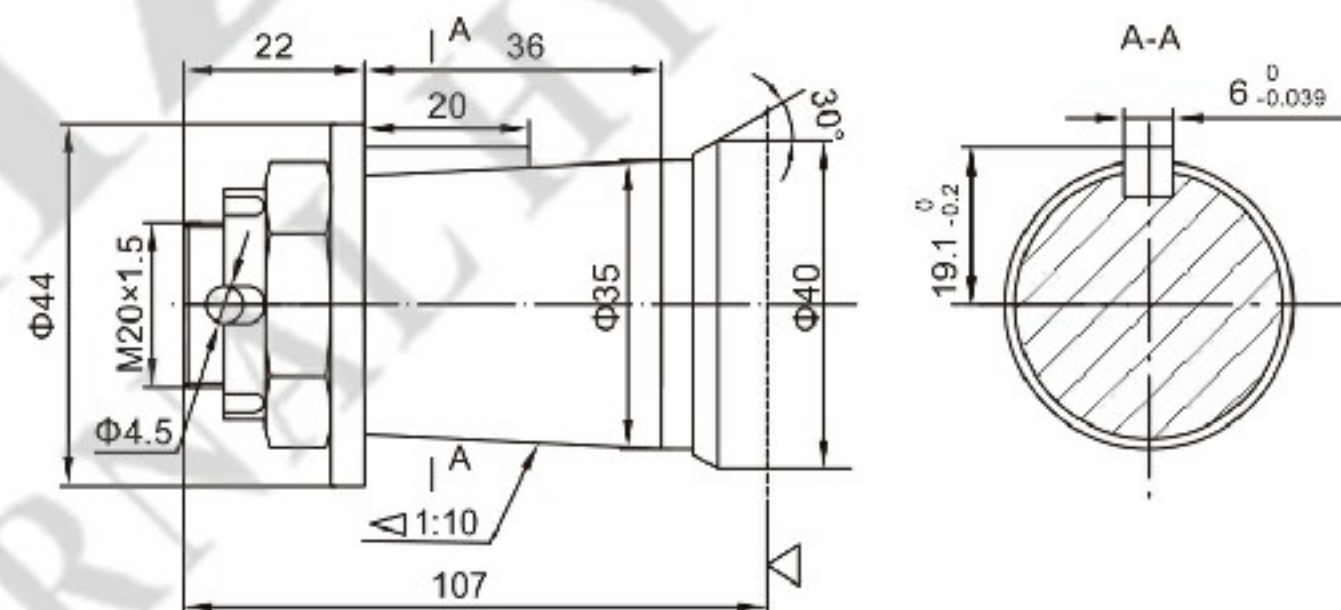

Z1: $\Phi 31.75$ 锥轴, 锥度1:8, 平键 $8 \times 7 \times 25$
 $\Phi 31.75$ Tapered shaft, taper 1:8, parallel key $8 \times 7 \times 25$

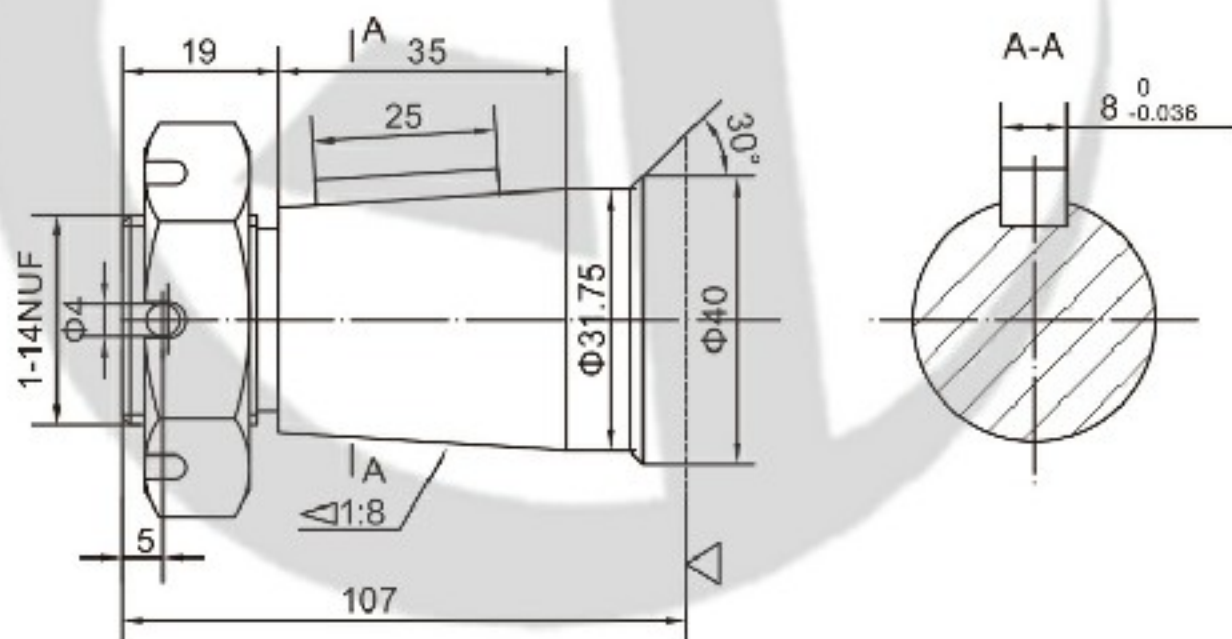

△ : 马达安装面
Motor mounting surface