

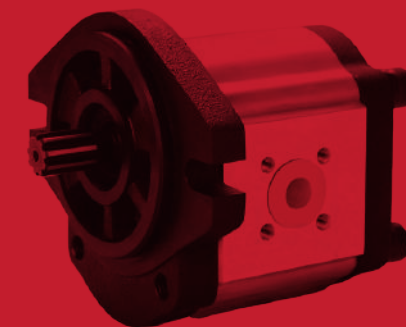

EXTERNAL GEAR PUMPS

0PF / 1PF / 1.5PF / 2PF / 2.5PF / 2.8PF / 3PF / 3.5PF / 4PF



SHANGHAI RYAN FLUID POWER CO.,LTD

Address: Rm 1703-2, 33#, 1228 Jiangchang Rd, Shanghai, China

Tel: +86-21-56626882

Email: sales@ryanhydraulic.com

Website: www.ryanhydraulic.com

Zip code: 200434



RYAN HYDRAULICS

Keep the concept seeking excellence, Ryan try our best to create more value for you with products and service.

Ryan Hydraulics

Supplier of the Whole Hydraulic System

Ryan Hydraulics manufacture was established in 1986, focusing on R&D, manufacture and sales of hydraulic products. Ryan Hydraulics owns world top level R&D team, as well as invention patents, sales covers global market. Targeting at vision of Excellence, Ryan Hydraulics keeps creating more value for customers by quality products, professional technology and experienced service.

645,835 sq.ft Modern Manufacture

Since the opening of 3rd generation modern manufacture in 2015, the total area covers 1,291,669 sq.ft, while the construction area covers 645,835 sq.ft, there are IT machining equipment, test and inspection equipment, meets various requirement of global customers.

Customer First

With leading technology, quality product, and professional service, Ryan Hydraulics has covered the global market with more than 60 countries and regions, become the strategic partner of many international famous OEM enterprises.

Instant Efficient Service

Technical Team offers accurate solutions to the service, including the product model selection, product test, installation and commissioning, debugging etc., so as to keep in touch with right department of each customer in time and respond to the customer's requirement.



9 Series Products

Covers the Whole Hydraulic Business

As a supplier of hydraulics, our business covers: hydraulic motors, hydraulic control valves, hydraulic gear pumps, power units and hydraulic systems, etc. Products are widely used in construction machinery, agricultural machinery, industry equipment.



Contents

Aluminum Single Pumps

0	Ordering Code	11
	0PF	12-16
1	Ordering Code	17
	1PF	18-20
	1HPF	21
	1APF	22
	1QEPP	23
	1QCPF	24
1.5	Ordering Code	25
	1.5PF	26
2	Ordering Code	27
	2PF	28
	2ABPF	29-30
	2LPF	31
	2APF	32-34
2.5	Ordering Code	35
	2.5APF	36
	2.5CPF	37
	2.5QPF	38
2.8	Ordering Code	39
	2.8APF	40
3	Ordering Code	41
	3APF	42-44
	3BPF	45
OM	OM08	46
	OM08-3	46
	OM401	47
	OM601	47
	OM701	48
	OM702	48
	OM14	49
2CP	2CP18	50-51
	2CB-E**/** HI/LO	52-53
PTO	PTO	54

Aluminum Multiple Pumps

1⁺	Ordering Code	55
	1DPF	56
1.5⁺	1.5BDPF	57
	1.5DPF	57
2⁺	2/1DPF	58
	2ADPF	59-60
	2ATPF	61-62
	2AFPF	63
3⁺	3/2ADPF	64
	3ADPF	65
	3ATPF	66
A	Application Guide of Multiple Pumps	67

Cast Iron Pumps

1	Ordering Code	75
	1EPF	76
2	2YBDPF	77
2.5	2.5YPF	78
	2.5EPF	79
3	3CPF	80
3.5	3.5EPF	81
	3.5APF	82-83
4	4PF	84
X	XTYBA	85
D	C101/C102 G101/G102 Dump Pumps	86
H	HGP	87
C	Cat Pumps	88
	Inlet/Outlet Combinations	95
	Types of Shafts	96
	Types of Front Covers	101

Introduction of Ryan External Gear Pumps

External gear pumps from Ryan Hydraulics have a floating bushing feature with automatic axial clearance compensation. The bushings are made with special abrasion resistant material providing improved service life. Precisely machined gears ensure our units provide excellent low noise characteristics. Our cold extrusion motor bodies can endure pressures above 30Mpa. High strength cast iron front and rear covers also enhance our reliability. Our units are widely used in the industrial mobile marine and aerospace industries.

Ryan External Gear Pump Characteristics

- Ryan external gear pumps are produced in 9 different versions(0P、1P、1.5P、2P、2.5P、2.8P、3P、3.5P、4P) and in each group different displacements are obtained by changing the gears width, refer to performance curves on page 7 to page 10.
- Pressure: Ryan offers two pressure ratings, F and G, please refer to charts.
- Efficiencies: volumetric efficiency up to 98%, mechanical efficiency up to 93%.
- Mountings: flanges, shaft ends and ports.
- Seals: viton,buna and EPR seals is available.
- Integrate: all pumps can be odered with relief valve and check valve.

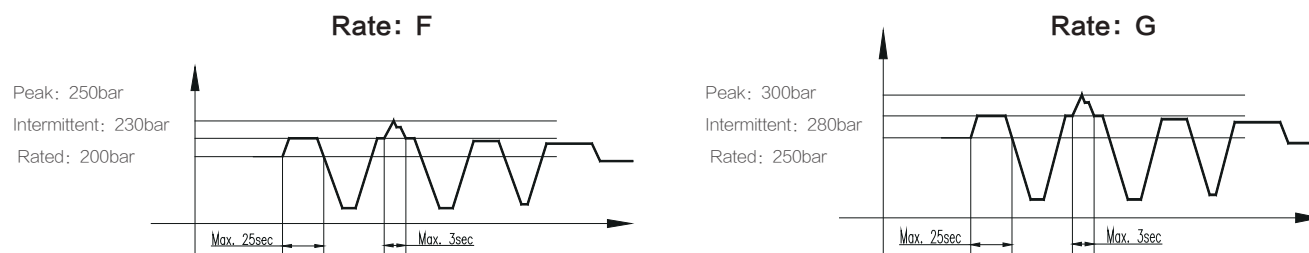

General

To achieve the performance it necessary not only to meet the catalogue but also to take real care of the design of the hydraulic as a whole.

- The design of the hydraulic circle, especially the suction line, dimension and position of the valves, the filters, the reservoirs and the heat exchangers.
- Ensure correct and frequent cleaning and maintenance of the circle and of the hydraulic fluid.
- Equip the circuit with suitable alarm and safety devices.
- Avoid possible starting under load at lower temperature .
- Avoid high pressure at low speed.
- In reason choice oil is major factor.

Hydraulic Fluid

Fluid must be specifically for hydraulic equipment, it must be foamless, anticorrosive, noncorrosive and have good lubricating features meeting the following requirements.

Recommended use: GB11118-94: L-HM46 or equate NFE-603/DIN51524 II -85

Minimum Working Speed

We recommend a minimum working speed for every pump group as follows

- 0P=800RPM
- 1P/3.5P/4P=600RPM
- 1P ~ 2.5P=500RPM
- 3P=400RPM

Hydraulic Circuits

- Avoid sharp restrictions and small radius bends.
- Place safety relief valve set at correct pressure and with good dynamic characteristic.
- Recommended fluid speed in the inlet line-1.6~5ft/s(0.5~1.5m/s).
- Recommended fluid speed in the delivery line-6.5~20ft/s(2~6m/s).
- Recommended fluid speed in the return line-5~10ft/s(1.5~3m/s).
- Reservoir should have a capacity about twice as much as the volume of delivered by the pump in one minute.
- The return and inlet pipe must be separated as far as possible and under the minimum level of the oil.
- Install pump in a well cleaned environment, and make sure, prior starting the system that all pipe and reservoir are perfectly clean it is recommended to filter the new oil at 8~10 μm, before filling the reservoir.
- Fill the pump with fluid before installing and check the direction of rotation.
- For the first run of the pump it is advisable to disconnection the pump discharge in order to purge the air from the system.

Recommended Fluid Cleanliness

- By far largest number of premature failures of gear pumps are due to contamination, filtering with clogging indicating and alarms is recommended.
- The initial contamination of the fluid must not exceed class 10 NAS 1638, pass experience has shown that even brand new fluid often exceed this value. In this case it is recommended below:60 μm inlet, and in the return side.

Standard \ Pressure	P<2000PSI(14MPa)	2000PSI(14MPa)<P<3050PSI(21MPa)	P>3050PSI(21MPa)
NAS1638	10	9	8
ISO4406	19/16	18/15	17/14
Filter	25 μm	20 μm	10 μm

Driving Arrangements

- The pump must be in line with the PTO.
- Do not apply radial or axial loads on the pump shafts, the use of three coupling is recommended.
- Make sure that the absorbed torque does not exceed the max torque allowed for the shaft.
- Belt and gear drives are not recommended because they apply axial and radial loads on the bearing.

Calculated Formulas

Displacement	Flow	Pressure	Speed	Power	Torque	Volumetric efficiency	Mechanical efficiency	Total Efficiency
(cm ³ /r)	(l/min)	(bar)	(r/min)	(kw)	(Nm)	98%	93%	91%
V	Q	p	n	P	M	η _v	η _m	η _t

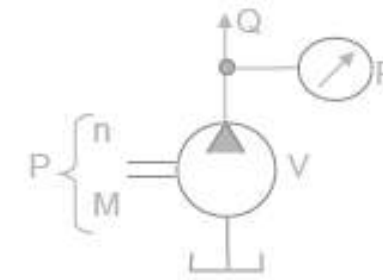

$$Q = V \cdot n \cdot \eta_v \cdot 10^3$$

$$M = p \cdot V / 62.83 \cdot \eta_m$$

$$P = p \cdot V \cdot n / 600 \cdot 1000 \cdot \eta_t$$

General Notes

- Deliveries are carried out under the conditions of Ryan Hydraulics.
- This catalog is issued to provide outline information only. we reserve the right to change without any notice the design, fractures.
- Please relat us if you have special request.

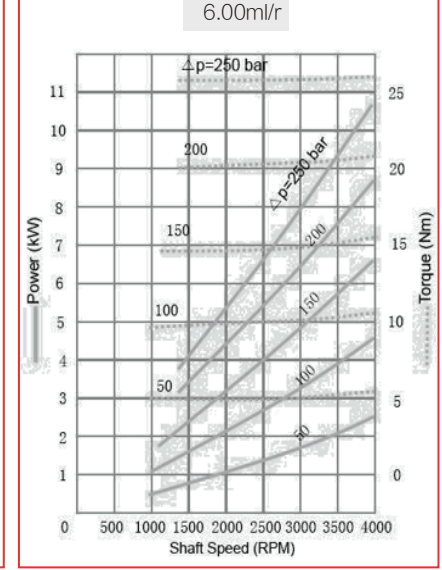
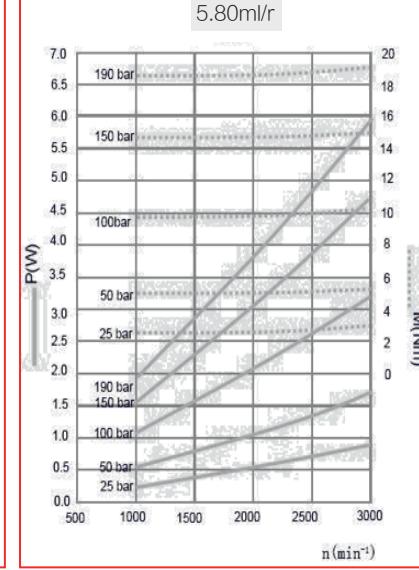
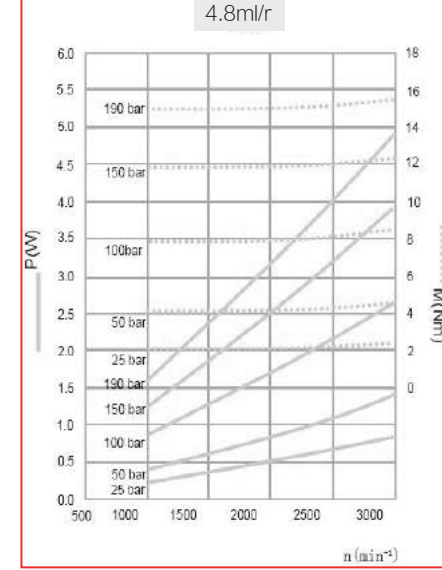
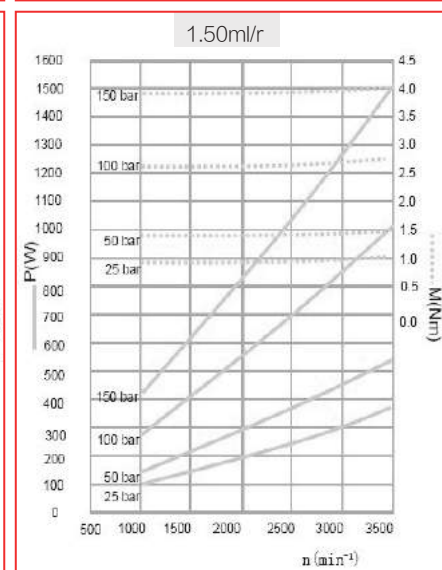
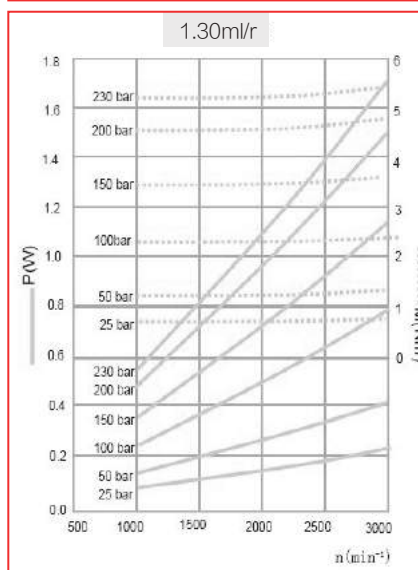
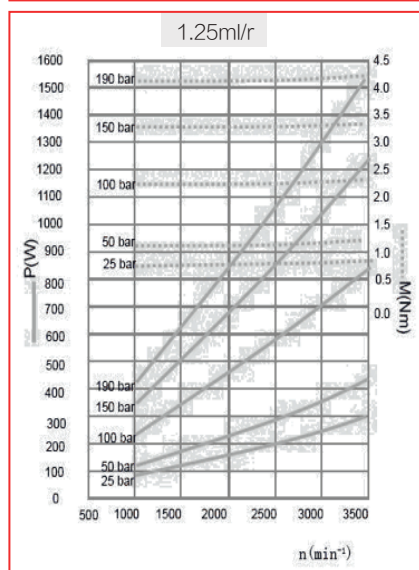
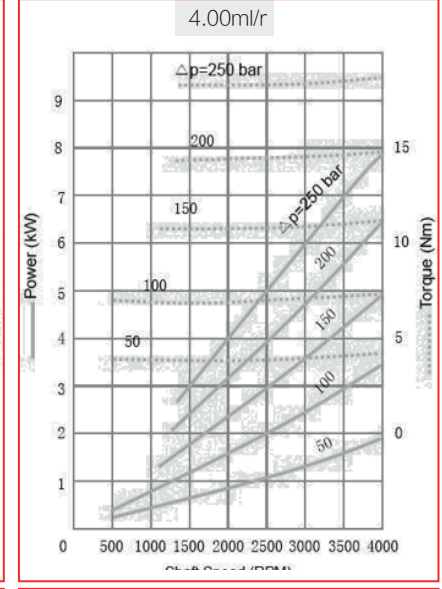
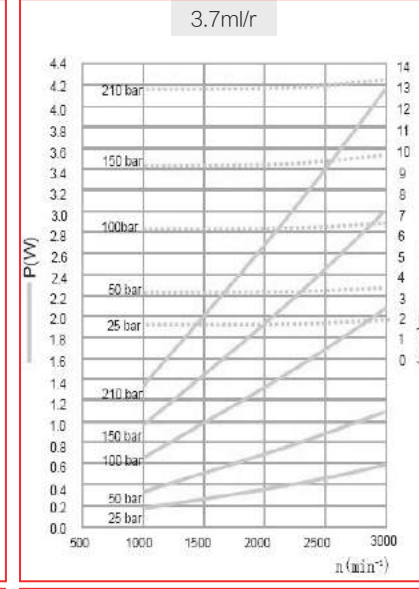
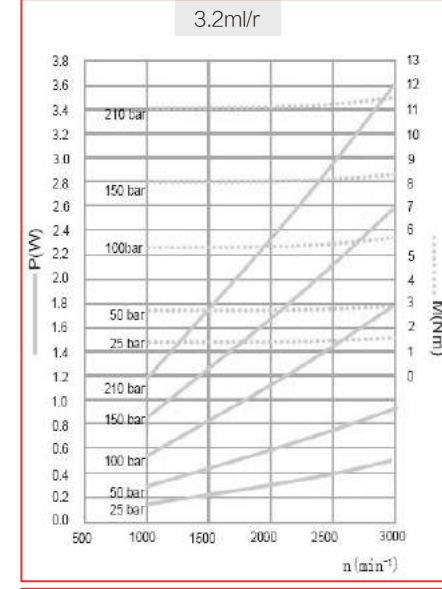
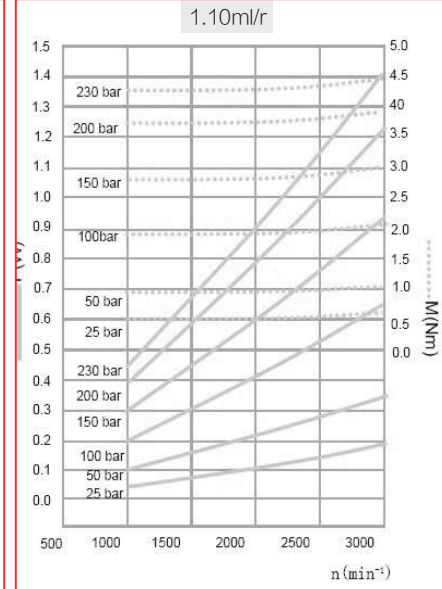
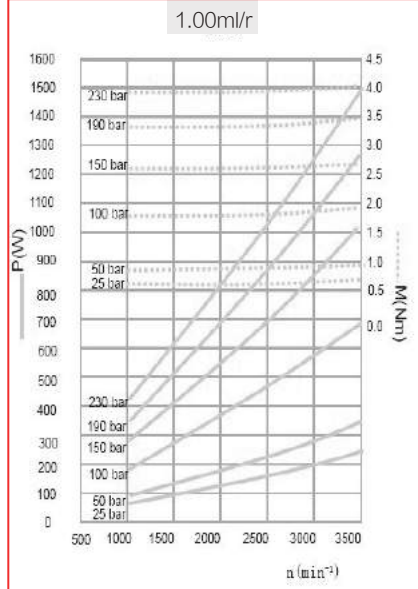
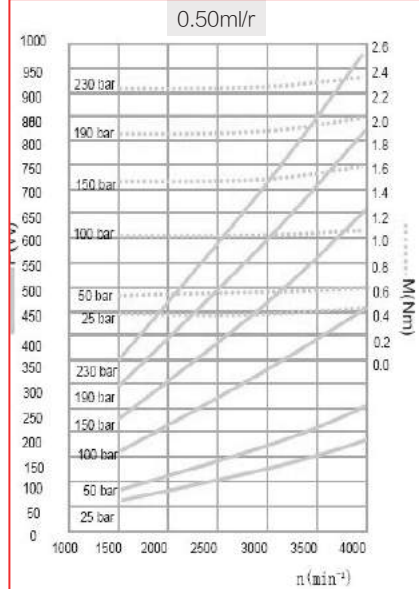
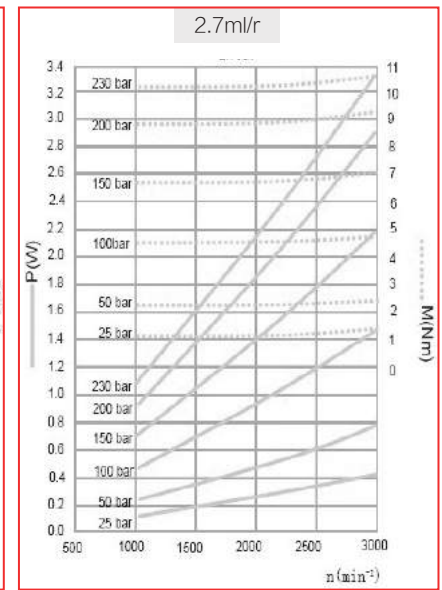
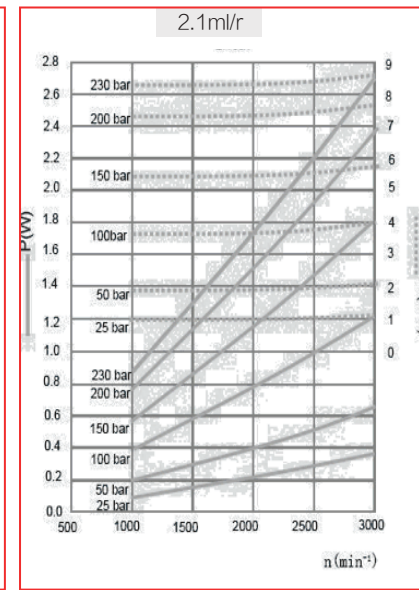
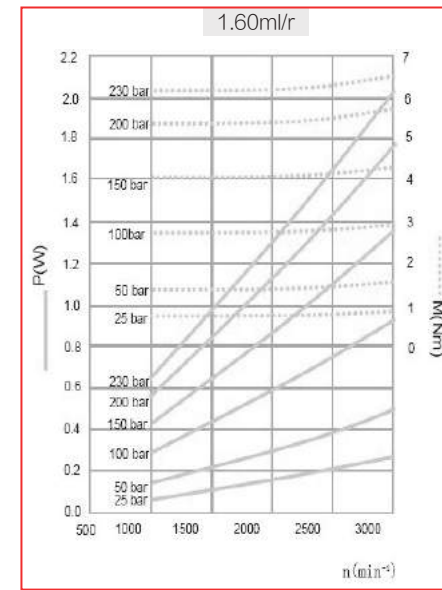
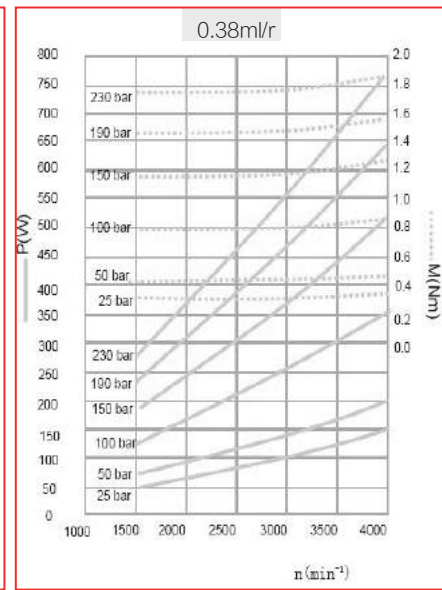
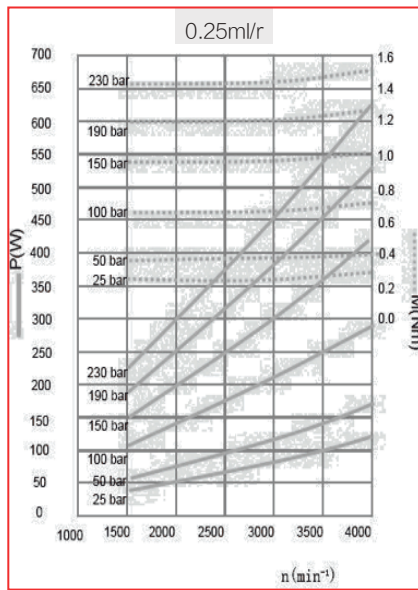
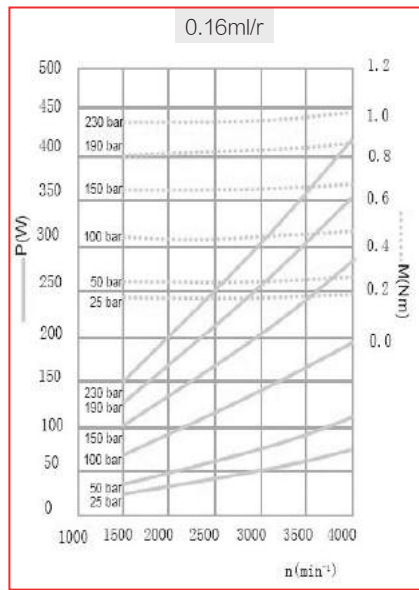

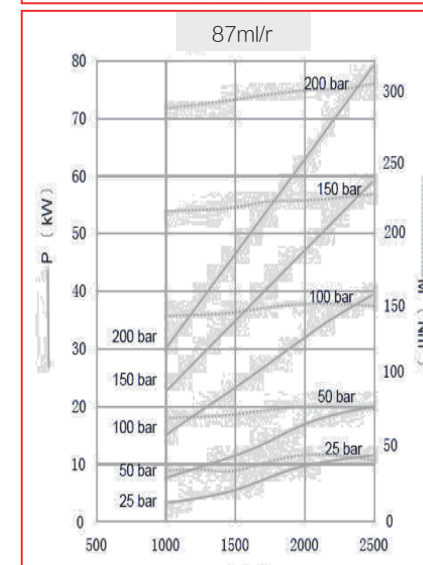
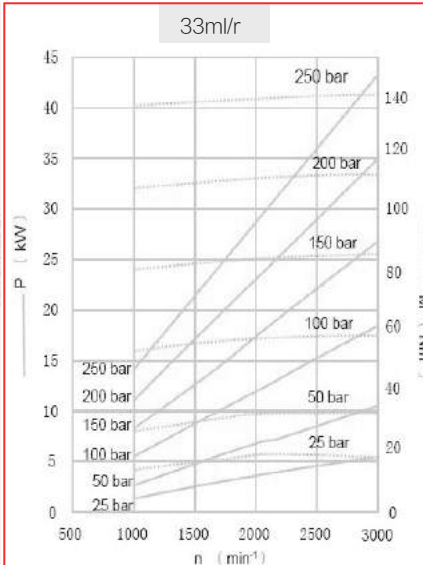
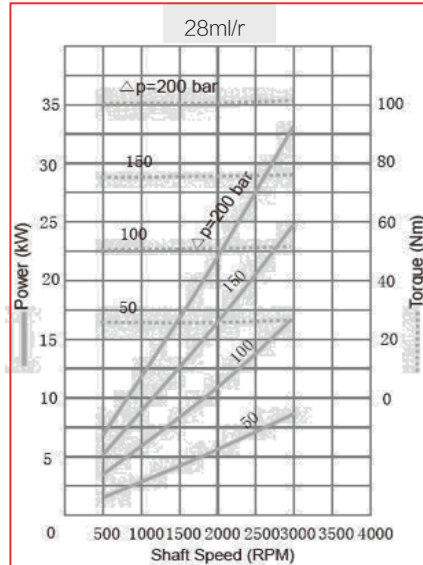
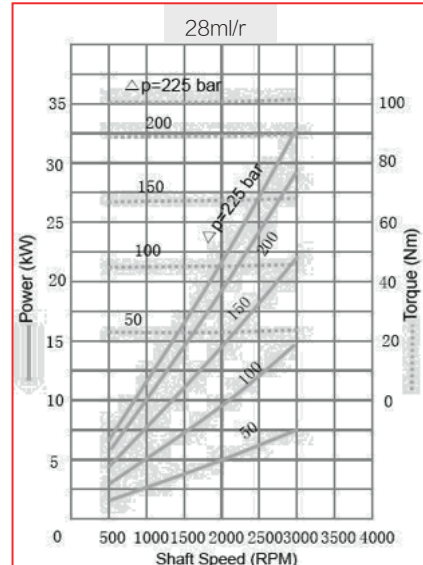
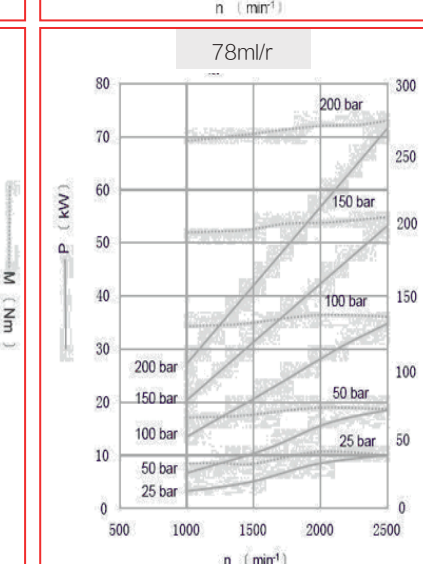
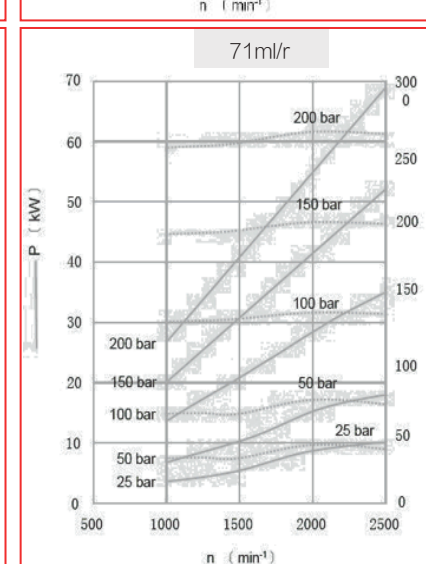
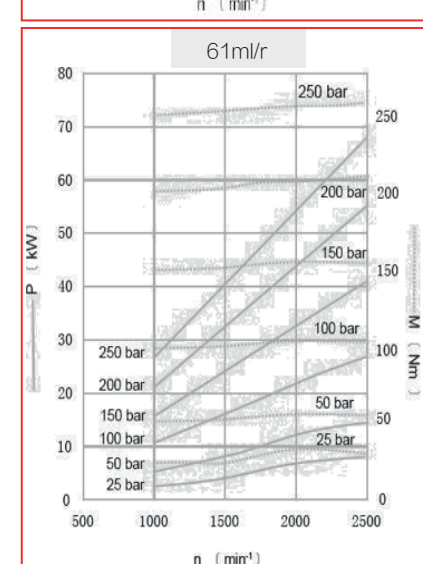
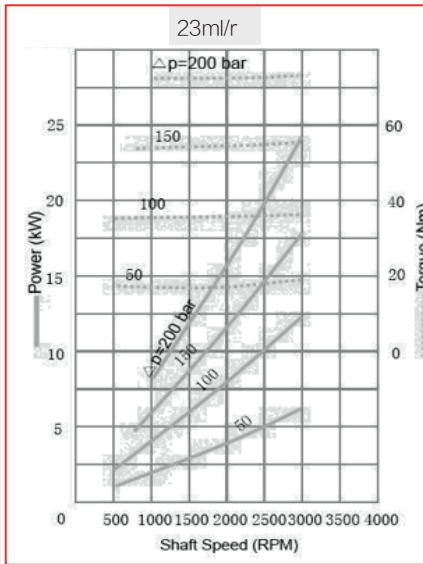
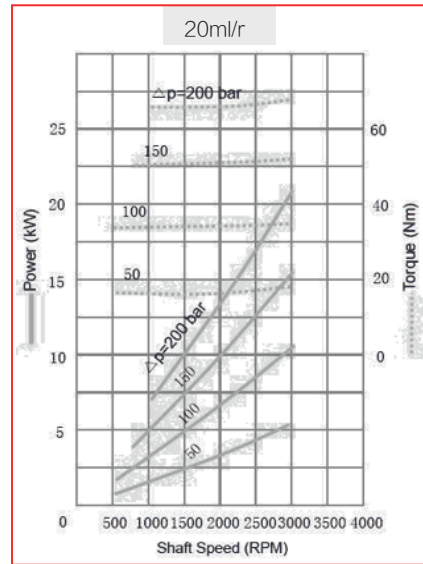
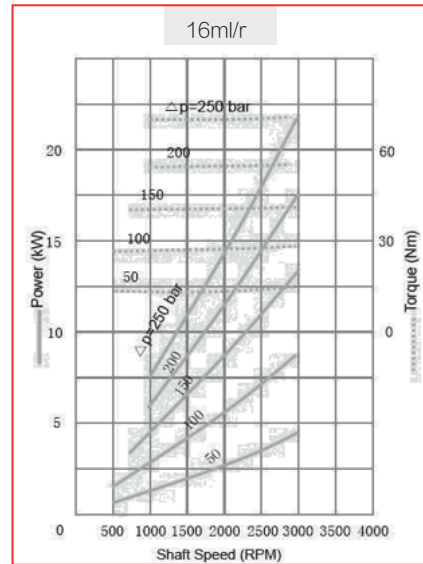
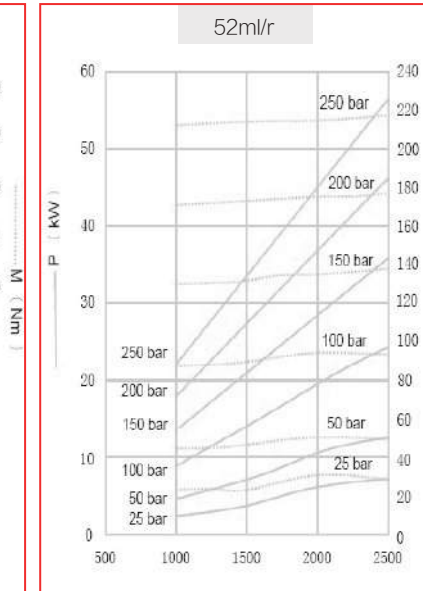
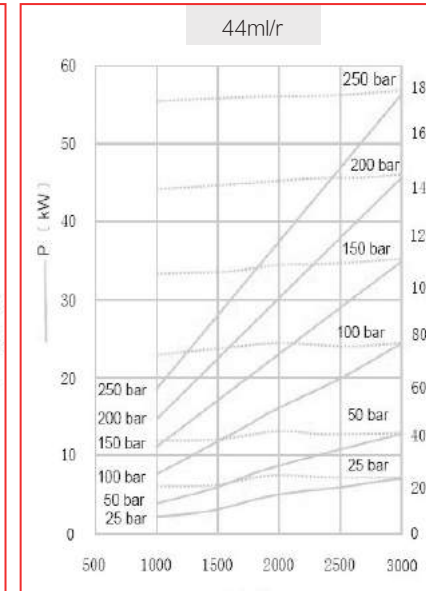
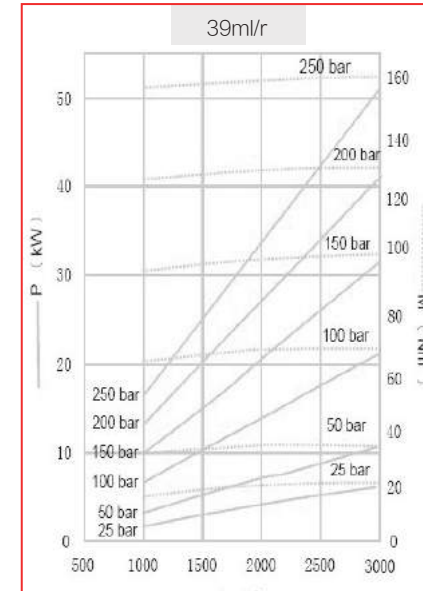
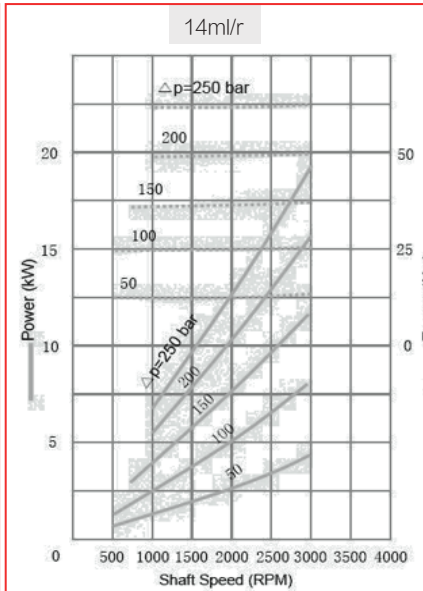
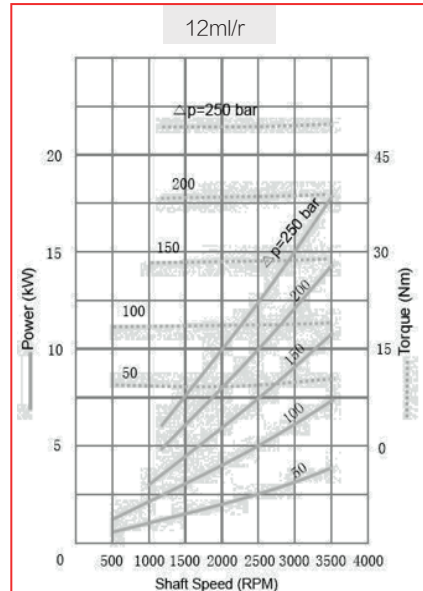
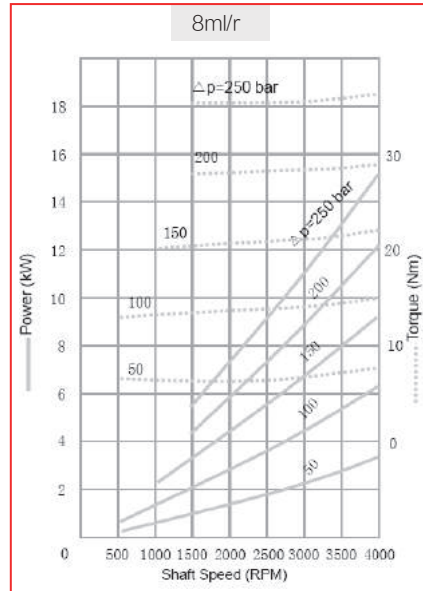

Aluminum Single Pump

0	P	F	0.16	L07	O3	O1	L-	BF-	F-	O	-V
a	b	c	d	e	f	g	h	i	j	k	l

- Ⓐ 0=Group 0
- Ⓑ P=Gear Pump
- Ⓒ Pressure Rate
E=160bar
F=200bar
G=250bar
- Ⓓ Displacement(ml/r)
0.16、0.25、0.38、0.5、0.75、1、1.25、1.5、1.75、2
- Ⓔ L07=Line ports
- Ⓕ O3=Drive shafts
- Ⓖ O1=Front covers
- Ⓗ Rotation
R=CW
L=CCW
B=Bi-directional
- Ⓘ Ports Combination
SS=side inlet and side outlet
BF=back inlet and front outlet
BB=back inlet and back outlet
- Ⓢ Seal
F=FKM Seal
Omit=NBR Seal
- Ⓚ Outboard Bearing
O=Outboard Bearing
Omit=Without Outboard Bearing
- Ⓛ Option
V=Relief valve
D=Check valve

Ⓔ Line ports Inlet/Outlet	Ⓕ Drive shafts	Ⓖ Front covers
L07 G1/4 Ø5.5x9.6x1.45mm	O3 Oblate shaft Ø8mm x 5.5	O3 2-hole mounting 32x30mm
L06 G1/4 G1/4	F1 Flat keyed shaft Ø7mm x 21	
K07 Ø9.6mm Ø5.5mm		
L61 M14x1.5 M14x1.5		

OPF**L**O3O1*



Model	Displacement (ml/r)	Pressure(bar)		Speed(r/min)			SS		Inlet
		Rated	Peak	Rated	Max	Min	L (mm)	L1 (mm)	
OPF0.16L07O3O1	0.16	200	250	3000	5000	800	58.2	30.8	G1/4
OPF0.25L07O3O1	0.25	200	250	3000	5000	800	59	31.3	
OPF0.38L07O3O1	0.38	200	250	3000	5000	800	60.3	31.9	
OPF0.50L07O3O1	0.50	200	250	3000	5000	800	61	32.3	
OPF0.75L07O3O1	0.75	200	250	3000	5000	800	63.5	33.5	
OPF1.00L07O3O1	1.00	200	250	3000	5000	800	66	34.8	
OPF1.25L07O3O1	1.25	200	250	3000	5000	800	68.5	36	
OPF1.50L07O3O1	1.50	200	250	3000	5000	800	70	37	
OPF1.75L07O3O1	1.75	160	200	3000	4500	800	73	38.3	
OPF2.00L07O3O1	2.00	160	200	3000	4500	800	75.5	39.5	

Dimensions

OPF**L06O3O1LSS

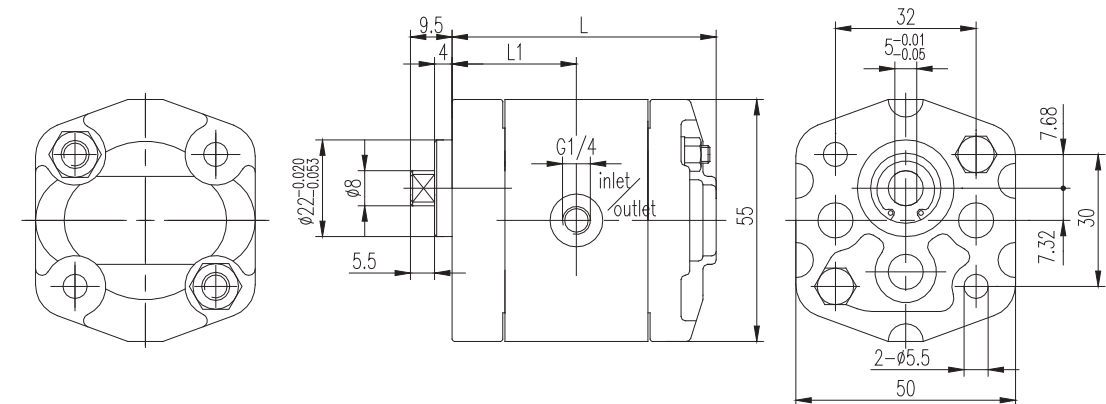

OPF**L07O3O1LBF

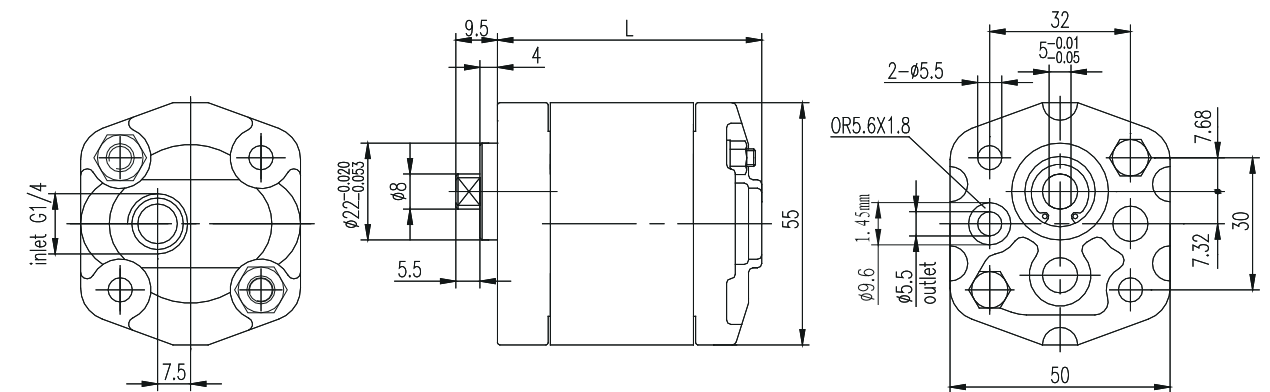

OPFK07O3O1B-FF**



Model	Displacement (ml/r)	Pressure(bar)		Speed(r/min)			FF L (mm)
		Rated	Peak	Rated	Max	Min	
0PF0.16K07O3O1B-FF	0.16	200	250	3000	5000	800	58.2
0PF0.25K07O3O1B-FF	0.25	200	250	3000	5000	800	59
0PF0.38K07O3O1B-FF	0.38	200	250	3000	5000	800	60.3
0PF0.50K07O3O1B-FF	0.50	200	250	3000	5000	800	61
0PF0.75K07O3O1B-FF	0.75	200	250	3000	5000	800	63.5
0PF1.00K07O3O1B-FF	1.00	200	250	3000	5000	800	66
0PF1.25K07O3O1B-FF	1.25	200	250	3000	5000	800	68.5
0PF1.50K07O3O1B-FF	1.50	200	250	3000	5000	800	70
0PF1.75K07O3O1B-FF	1.75	160	200	3000	4500	800	73
0PF2.00K07O3O1B-FF	2.00	160	200	3000	4500	800	75.5

Dimensions

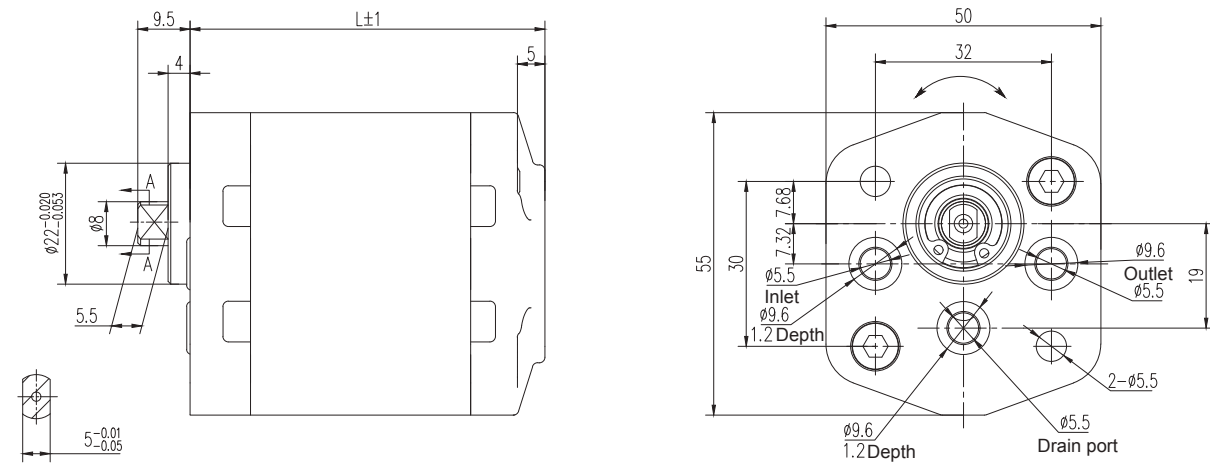

OPF **LO3O1B-BF-D**



Model	Displacement (ml/r)	Pressure(bar)		Speed(r/min)			Rotation	Inlet	Outlet	Drain Port
		Rated	Peak	Rated	Max	L (mm)				
0PF0.16L07O3O1B-BF-D	0.16	200	250	3000	5000	66.4	Bi-directional	G 1/4	$\phi 5.5$	$\phi 5.5$
0PF0.20L07O3O1B-BF-D	0.20	200	250	3000	5000	66.7				
0PF0.25L07O3O1B-BF-D	0.25	200	250	3000	5000	67.1				
0PF0.32L07O3O1B-BF-D	0.32	200	250	3000	5000	67.6				
0PF0.38L07O3O1B-BF-D	0.38	200	250	3000	5000	68.1				
0PF0.50L07O3O1B-BF-D	0.50	200	250	3000	5000	69.1				
0PF0.63L07O3O1B-BF-D	0.63	200	250	3000	5000	70.1				
0PF0.75L07O3O1B-BF-D	0.75	200	250	3000	5000	71.1				
0PF0.80L07O3O1B-BF-D	0.80	200	250	3000	5000	71.5				
0PF1.00L07O3O1B-BF-D	1.00	200	250	3000	5000	73.1				
0PF1.25L07O3O1B-BF-D	1.25	200	250	3000	5000	75.1				
0PF1.50L07O3O1B-BF-D	1.50	200	250	3000	5000	77.1				
0PF1.75L07O3O1B-BF-D	1.75	160	200	3000	4500	79.1				
0PF2.00L07O3O1B-BF-D	2.00	160	200	3000	4500	81.1				

Dimensions

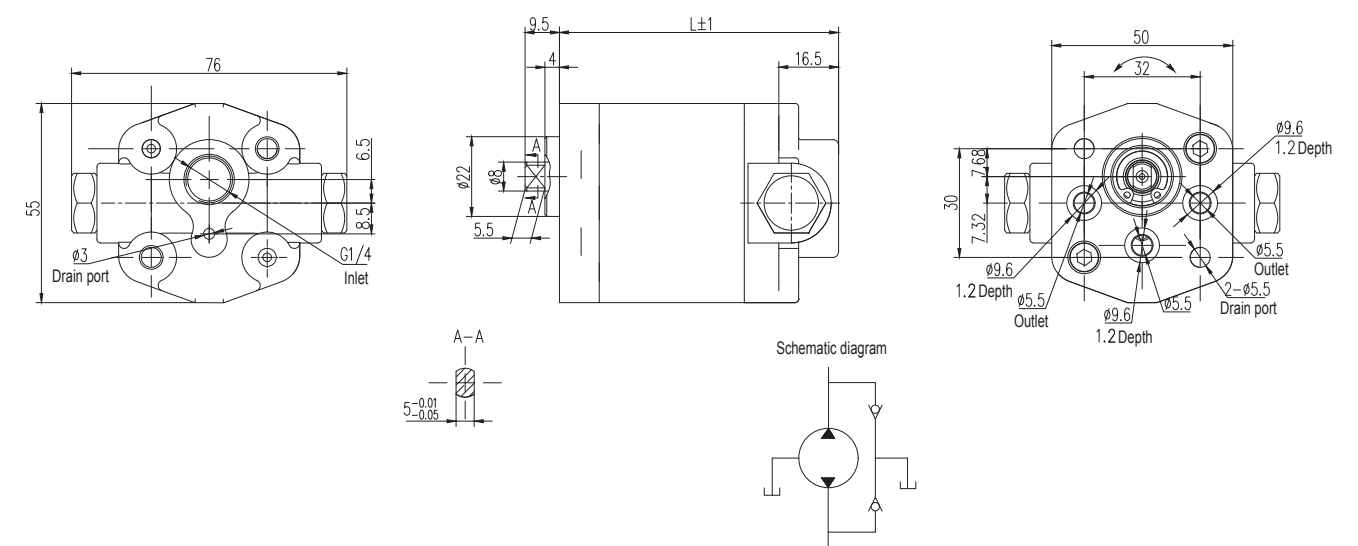

OPF **K07O3SP3B-BB



Model	Displacement (ml/r)	Pressure(bar)		Speed(r/min)			Rotation	Inlet and Outlet	Drain Port
		Rated	Peak	Rated	Max	L (mm)			
OPF0.16K07O3SP3B-BB	0.16	200	250	3000	5000	60.9	Bi-directional	ø5.5	ø5.5
OPF0.20K07O3SP3B-BB	0.20	200	250	3000	5000	61.2			
OPF0.25K07O3SP3B-BB	0.25	200	250	3000	5000	61.6			
OPF0.32K07O3SP3B-BB	0.32	200	250	3000	5000	62.1			
OPF0.38K07O3SP3B-BB	0.38	200	250	3000	5000	62.5			
OPF0.50K07O3SP3B-BB	0.50	200	250	3000	5000	63.5			
OPF0.63K07O3SP3B-BB	0.63	200	250	3000	5000	64.5			
OPF0.75K07O3SP3B-BB	0.75	200	250	3000	5000	65.6			
OPF0.80K07O3SP3B-BB	0.80	200	250	3000	5000	66			
OPF1.00K07O3SP3B-BB	1.00	200	250	3000	5000	67.6			
OPF1.25K07O3SP3B-BB	1.25	200	250	3000	5000	69.6			
OPF1.50K07O3SP3B-BB	1.50	200	250	3000	5000	71.6			
OPF1.75K07O3SP3B-BB	1.75	160	200	3000	4500	73.6			
OPF2.00K07O3SP3B-BB	2.00	160	200	3000	4500	75.6			

Dimensions

OPFK07O3SP3B-BB**

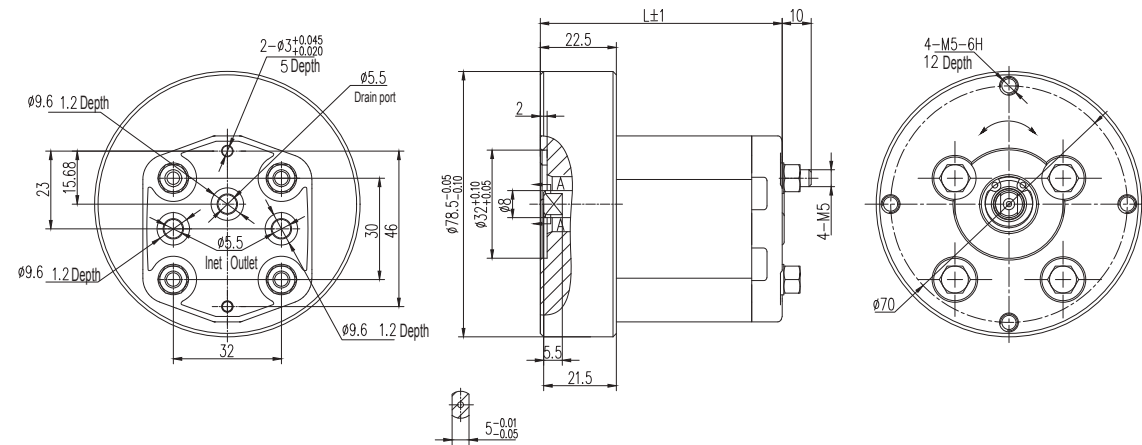

OPFK07O3SP3HB-BB**

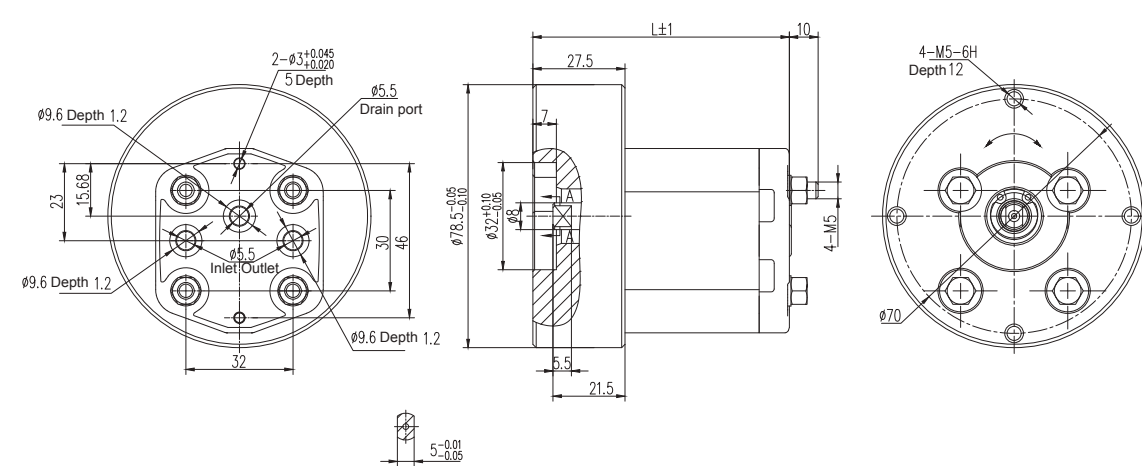

OPF **LF1D1***

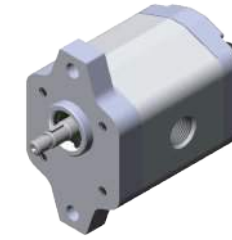

Model	Displacement (ml/r)	Pressure(bar)		Speed(r/min)			L(mm)	L1(mm)
		Rated	Peak	Rated	Max	Min		
OPF0.16L61F1D1*	0.16	200	250	3000	5000	800	57.7	26.9
OPF0.25L61F1D1*	0.25	200	250	3000	5000	800	58.5	27.3
OPF0.38L61F1D1*	0.38	200	250	3000	5000	800	59.8	27.9
OPF0.50L61F1D1*	0.50	200	250	3000	5000	800	60.5	28.3
OPF0.63L61F1D1*	0.63	200	250	3000	5000	800	62	29
OPF0.75L61F1D1*	0.75	200	250	3000	5000	800	63	29.5
OPF1.00L61F1D1*	1.00	200	250	3000	5000	800	65.5	30.8
OPF1.25L61F1D1*	1.25	200	250	3000	5000	800	68	32
OPF1.50L61F1D1*	1.50	200	250	3000	5000	800	70	33
OPF1.75L61F1D1*	1.75	160	200	3000	4500	800	72.5	34.3
OPF2.00L61F1D1*	2.00	160	200	3000	4500	800	75	35.5

Dimensions

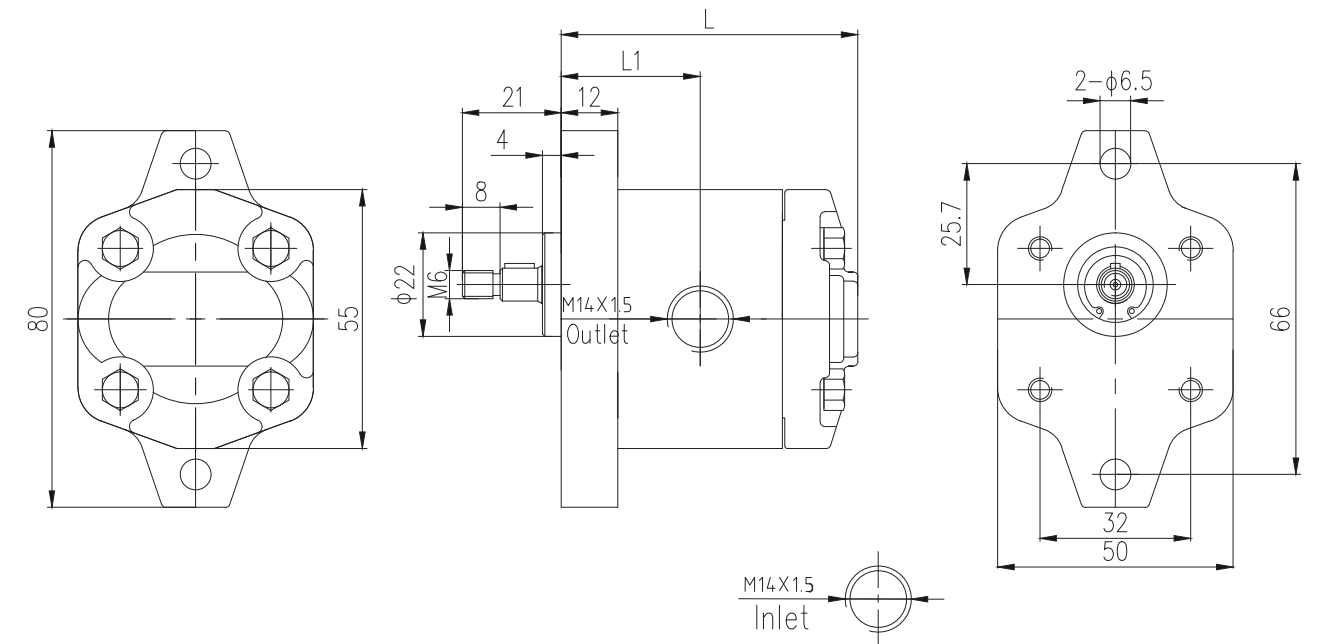

1 * P F 2.7 L01 T3 O2 L- SS F- O -V
a | b | c | d | e | f | g | h | i | j | k | l | m

- Ⓐ 1=Group 1
- Ⓑ Improve number
Omit=Aluminum covers and body
A=Cast iron covers
AB=Low noise
QC/QE=Special type
- Ⓒ P=Gear Pump
- Ⓓ Pressure Rate
E=160bar
F=200bar
G=250bar
- Ⓔ Displacement(ml/r)
1.1, 1.3, 1.6, 1.8, 2.1, 2.7, 3.2, 3.7, 4.2, 4.8, 5.8, 8
- Ⓕ L01=Line ports
- Ⓖ T3=Recommend Drive shafts
- Ⓗ O2=Front covers
- Ⓘ Rotation
R=CW
L=CCW
B=Bi-directional
- Ⓚ Ports Combination
SS=Side inlet and side outlet
SB=Side inlet and back outlet
BS=Back inlet and Side outlet
- Ⓛ Seal
F=FKM Seal
Omit=NBR Seal
- Ⓜ Outboard Bearing
O=Outboard Bearing
Omit=Without Outboard Bearing
- Ⓝ Option
V=Relief valve
D=Check valve

Ⓕ Line ports Inlet/Outlet	Ⓖ Drive shafts	Ⓗ Front covers
L01 G3/8 Ø9x12.7x1.45mm	O11 Oblate shaft Ø5mm x 7	O2 2-hole mounting 40x40mm
L46 G3/8 G3/8	T3 Tapered key shaft 1:5	S5 4-hole mounting 52.4x71.9mm
L04 G1/2 G1/2	F16 Flat keyed shaft SAE AA Ø12.7mm	D2 2-groove mounting Ø 82.55mm
L05 G1/2 G3/8		
LJ37 7/8-14UNF-2B 3/4-16UNF-2B		

1PF*L**O11O2***



Model	Displacement (ml/r)	Pressure(bar)		Speed(r/min)			L (mm)	L1 (mm)	L2 (mm) SS	Inlet
		Rated	Peak	Rated	Max	Min				
1PF1.1L01O11O2*	1.1	200	250	3000	6000	600	74	63	33	G3/8
1PF1.3L01O11O2*	1.3	200	250	3000	6000	600	75	64	33.5	
1PF1.6L01O11O2*	1.6	200	250	3000	6000	600	76	65	34	
1PF1.8L01O11O2*	1.8	200	250	3000	6000	600	77	66	34.5	
1PF2.1L01O11O2*	2.1	200	250	3000	6000	600	78	67	35	
1PF2.7L01O11O2*	2.7	200	250	3000	6000	600	80	69	36	
1PF3.2L01O11O2*	3.2	200	250	3000	5000	600	82	71	37	
1PF3.7L01O11O2*	3.7	200	250	3000	4500	600	84	73	38	
1PF4.2L01O11O2*	4.2	200	250	3000	4000	600	86	75	39	
1PF4.8L01O11O2*	4.8	160	200	3000	3500	600	88	77	40	
1PF5.8L01O11O2*	5.8	160	200	3000	2900	600	92	81	42	
1PF8.0L01O11O2*	8.0	160	200	3000	2100	600	100	89	46	

Dimensions

1PF*L01O11O2**

Option: With Relief Valve

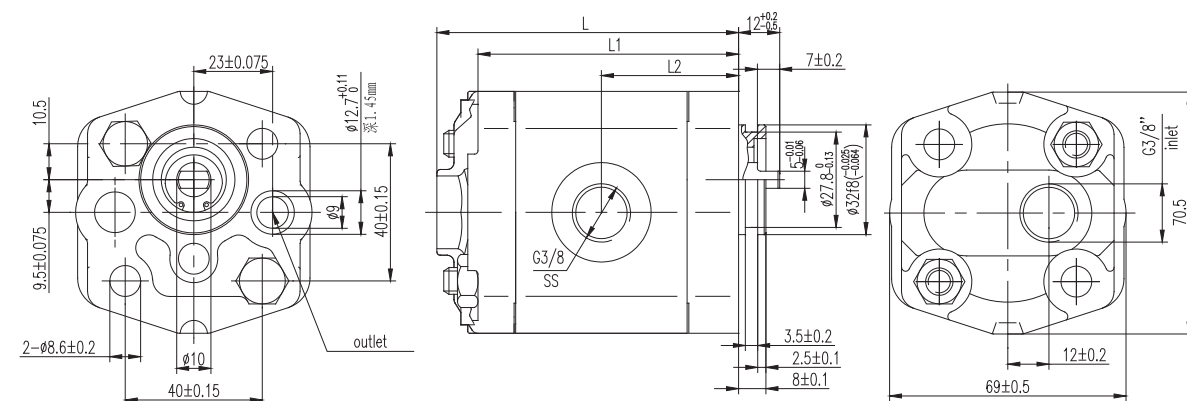

1PF*L01O11O2-BF-V**

Adjusted Pressure of Relief Valve 50~250 Bar

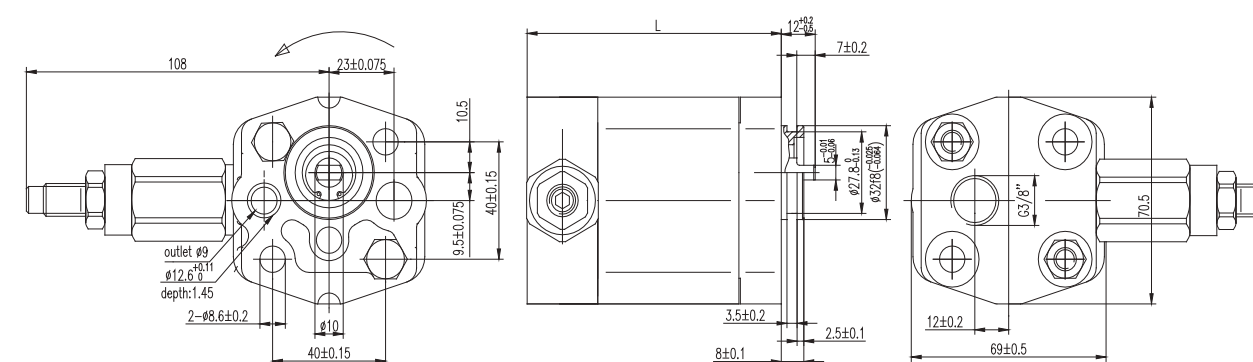

1PFL**T3S5***



1PFL04F9SP15L-O-V-J**

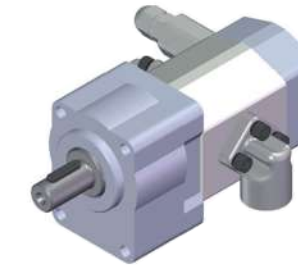

Model	Displacement (ml/r)	Pressure(bar)		Speed(r/min)			L (mm)	L1 (mm)
		Rated	Peak	Rated	Max	Min		
1PF1.1**L46T3S5*	1.1	200	250	3000	6000	600	75	33
1PF1.3**L46T3S5*	1.3	200	250	3000	6000	600	76	34
1PF1.6**L46T3S5*	1.6	200	250	3000	6000	600	78	35
1PF1.8**L46T3S5*	1.8	200	250	3000	6000	600	78.5	35.5
1PF2.1**L46T3S5*	2.1	200	250	3000	6000	600	79	36
1PF2.7**L46T3S5*	2.7	200	250	3000	6000	600	81	37
1PF3.2**L46T3S5*	3.2	200	250	3000	5000	600	83	38
1PF3.7**L46T3S5*	3.7	200	250	3000	4500	600	85	39
1PF4.2**L46T3S5*	4.2	200	250	3000	4000	600	87	40
1PF4.8**L46T3S5*	4.8	160	200	3000	3500	600	89	41
1PF5.8**L46T3S5*	5.8	160	200	3000	2900	600	93	43
1PF8.0**L46T3S5*	8.0	160	200	3000	2100	600	101	47

Model	Displacement (ml/r)	Pressure(bar)		Speed(r/min)			L (mm)	L1 (mm)
		Rated	Peak	Rated	Max	Min		
1PF1.1L04F9SP15L-O-V-J	1.1	200	250	3000	6000	600	75	33
1PF1.3L04F9SP15L-O-V-J	1.3	200	250	3000	6000	600	76	34
1PF1.6L04F9SP15L-O-V-J	1.6	200	250	3000	6000	600	78	35
1PF1.8L04F9SP15L-O-V-J	1.8	200	250	3000	6000	600	78.5	35.5
1PF2.1L04F9SP15L-O-V-J	2.1	200	250	3000	6000	600	79	36
1PF2.7L04F9SP15L-O-V-J	2.7	200	250	3000	6000	600	81	37
1PF3.2L04F9SP15L-O-V-J	3.2	200	250	3000	5000	600	83	38
1PF3.7L04F9SP15L-O-V-J	3.7	200	250	3000	4500	600	85	39
1PF4.2L04F9SP15L-O-V-J	4.2	200	250	3000	4000	600	87	40
1PF4.8L04F9SP15L-O-V-J	4.8	160	200	3000	3500	600	89	41
1PF5.8L04F9SP15L-O-V-J	5.8	160	200	3000	2900	600	93	43
1PF8.0L04F9SP15L-O-V-J	8.0	160	200	3000	2100	600	101	47

Dimensions

1PFL46T3S5SS**

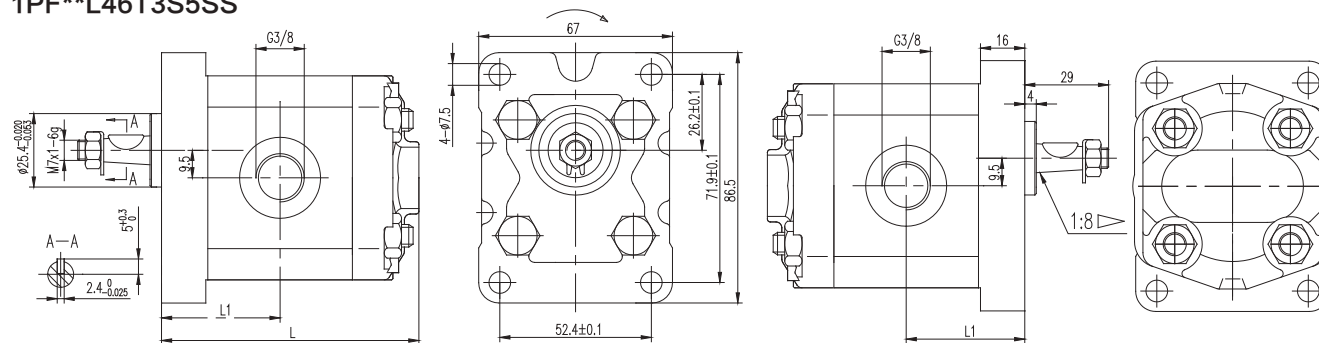

1PF*L46T3S5-V**

Option: With Relief Valve

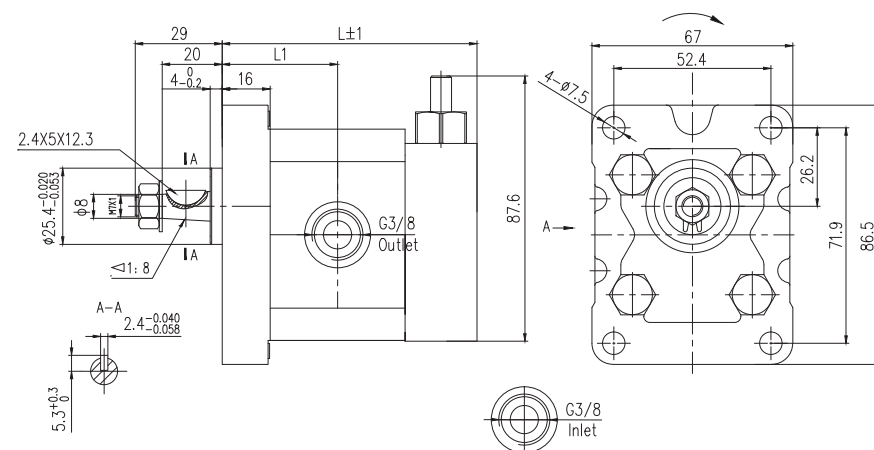

Dimensions

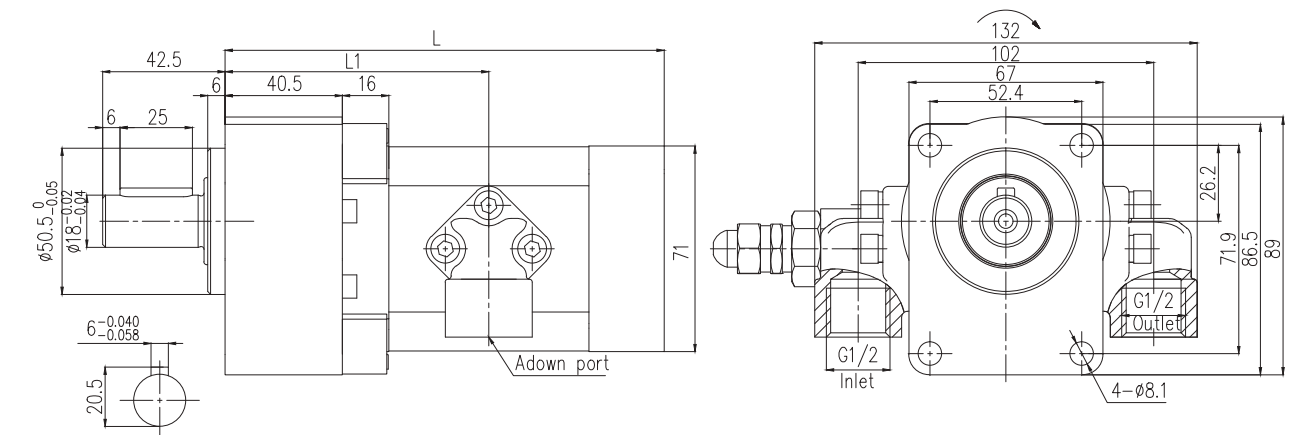

1HPF**L147S93SP4LFB



Model	Displacement (ml/r)	Pressure(bar)		Speed(r/min)			L (mm)	L1 (mm)
		Rated	Peak	Rated	Max	Min		
1HPF**L147S93SP4LFB	1.1	140	200	3000	4000	600	79	40
1HPF**L147S93SP4LFB	1.3	140	200	3000	4000	600	79	40
1HPF**L147S93SP4LFB	1.6	140	200	3000	4000	600	79	40
1HPF**L147S93SP4LFB	1.8	140	200	3000	4000	600	79	40
1HPF**L147S93SP4LFB	2.1	140	200	3000	4000	600	79	40
1HPF**L147S93SP4LFB	2.3	140	200	3000	4000	600	79	40
1HPF**L147S93SP4LFB	2.5	140	200	3000	4000	600	79	40
1HPF**L147S93SP4LFB	2.7	140	200	3000	4000	600	79	40
1HPF**L147S93SP4LFB	3.2	140	250	3000	4000	600	99	60
1HPF**L147S93SP4LFB	3.3	140	200	3000	4000	600	99	60
1HPF**L147S93SP4LFB	3.4	140	200	3000	4000	600	99	60
1HPF**L147S93SP4LFB	3.7	140	200	3000	4000	600	99	60
1HPF**L147S93SP4LFB	4.2	140	200	3000	4000	600	99	60
1HPF**L147S93SP4LFB	4.8	140	200	3000	4000	600	99	60
1HPF**L147S93SP4LFB	5.8	140	200	3000	4000	600	99	60
1HPF**L147S93SP4LFB	6.0	140	200	3000	4000	600	99	60
1HPF**L147S93SP4LFB	6.2	140	200	3000	4000	600	99	60
1HPF**L147S93SP4LFB	7.0	140	200	3000	4000	600	99	60
1HPF**L147S93SP4LFB	8.0	140	200	3000	4000	600	101	60

Dimensions

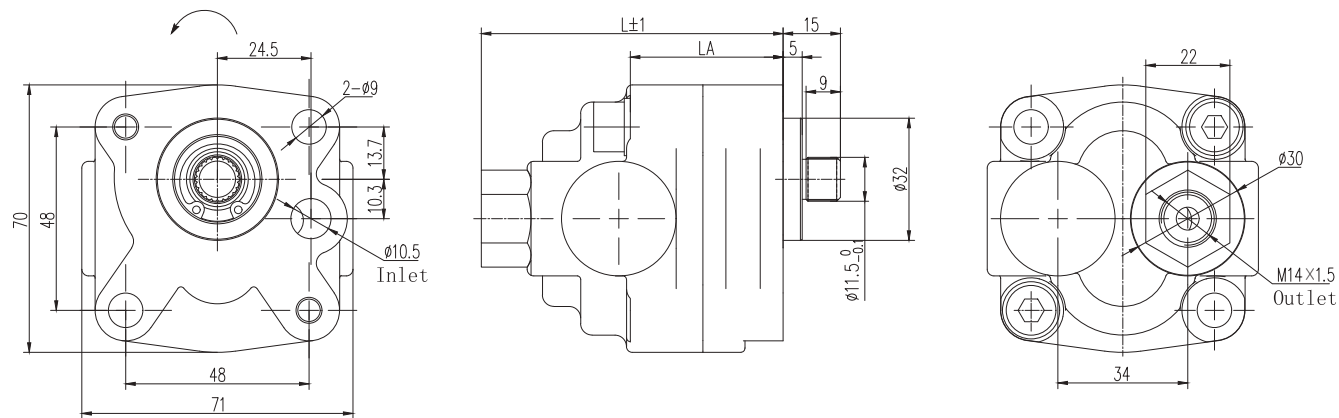

1PF***L**F16D2*



Model	Displacement (ml/r)	Pressure(bar)		Speed(r/min)			A (mm)	B (mm)	D	
		Rated	Peak	Rated	Max	Min			In	Out
1PF1.3L05F16D2*	1.3	200	250	3000	4500	500	82	42	G 1/2	G 3/8
1PF2.0L05F16D2*	2.0	200	250	3000	4500	500	84	43		
1PF2.7L05F16D2*	2.7	200	250	3000	4500	500	86	44		
1PF3.4L05F16D2*	3.4	200	250	3000	4500	500	88	45		
1PF4.1L05F16D2*	4.1	200	250	3000	4500	500	90	46		
1PF5.1L05F16D2*	5.1	200	250	3000	4500	500	93	47.5		
1PF6.1L05F16D2*	6.1	200	250	3000	4500	500	96	49		
1PF7.1L05F16D2*	7.1	200	250	3000	4500	500	101	50.5		

Dimensions

1PF***L**F16D2*

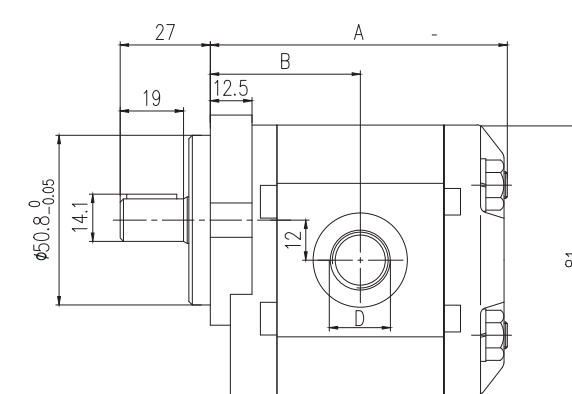

Option:1APF with relief valves

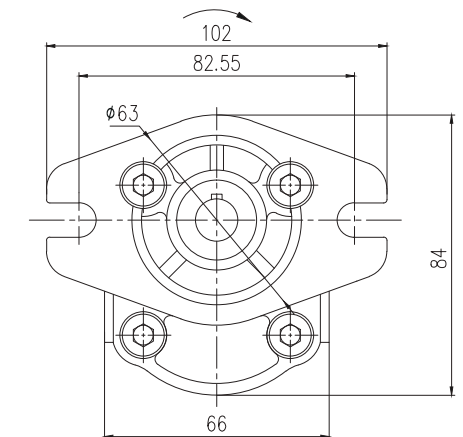

1APF**LJ35F16D4L

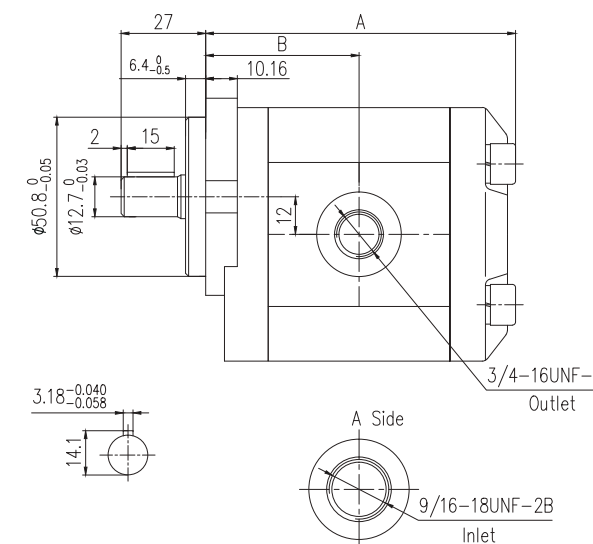

1QEPPF **K06T48SP6



Model	Displacement (ml/r)	Pressure(bar)		Speed(r/min)			L (mm)
		Rated	Peak	Rated	Max	Min	
1QEPPF0.8K06T48SP6	0.8	200	250	3000	4000	500	80.3
1QEPPF1.1K06T48SP6	1.1	200	250	3000	4000	500	80.8
1QEPPF1.6K06T48SP6	1.6	200	250	3000	4000	500	82.8
1QEPPF2.5K06T48SP6	2.5	200	250	3000	4000	500	86.3
1QEPPF3.2K06T48SP6	3.2	200	250	3000	3500	500	80.0

Dimensions

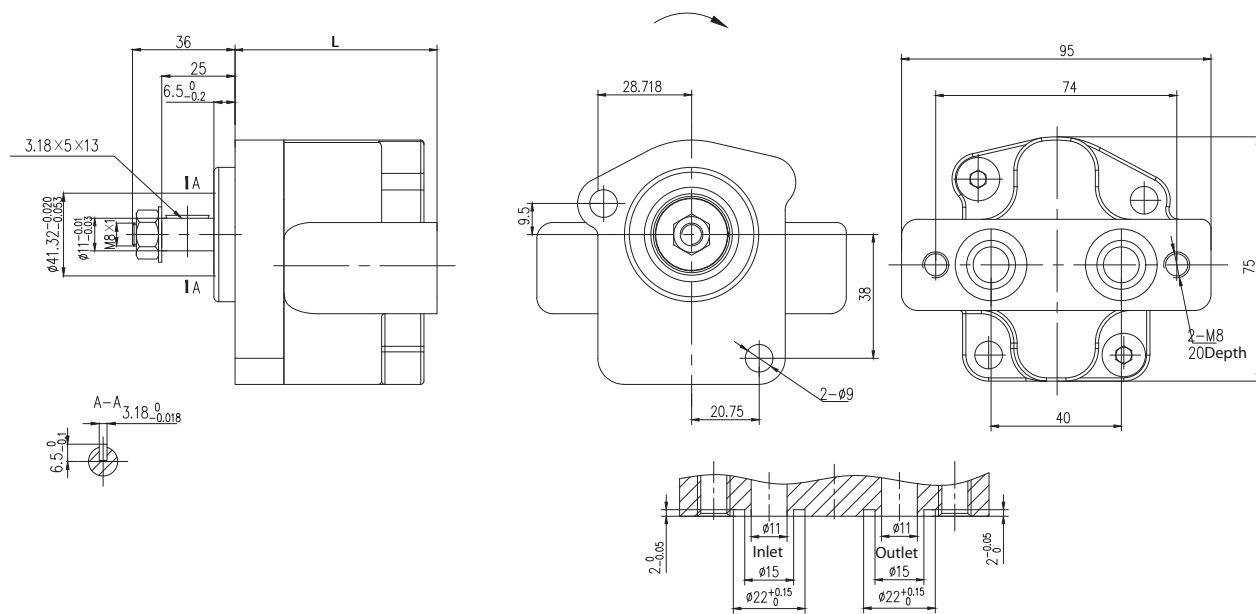

1QCPF **L**O30SP5*



Model	Displacement (ml/r)	Pressure(bar)		Speed(r/min)			L (mm)	L1 (mm)
		Rated	Peak	Rated	Max	Min		
1QCPF0.8L04O30SP5*	0.8	200	250	3000	4000	500	80.3	40.8
1QCPF1.1L04O30SP5*	1.1	200	250	3000	4000	500	80.8	41
1QCPF1.6L04O30SP5*	1.6	200	250	3000	4000	500	82.8	42
1QCPF2.5L04O30SP5*	2.5	200	250	3000	4000	500	86.3	43.8
1QCPF3.2L04O30SP5*	3.2	200	250	3000	4000	500	88.8	45

Dimensions

1QCPF**L04O30SP5L

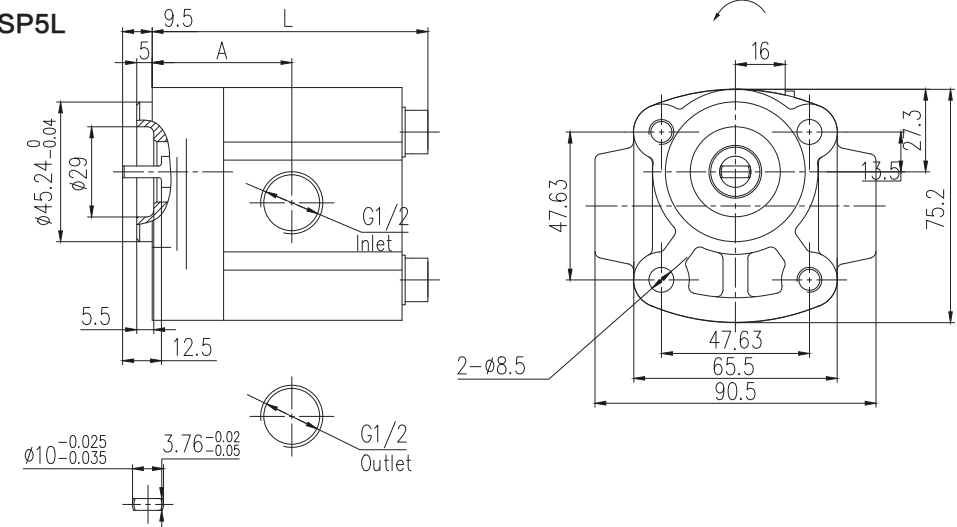

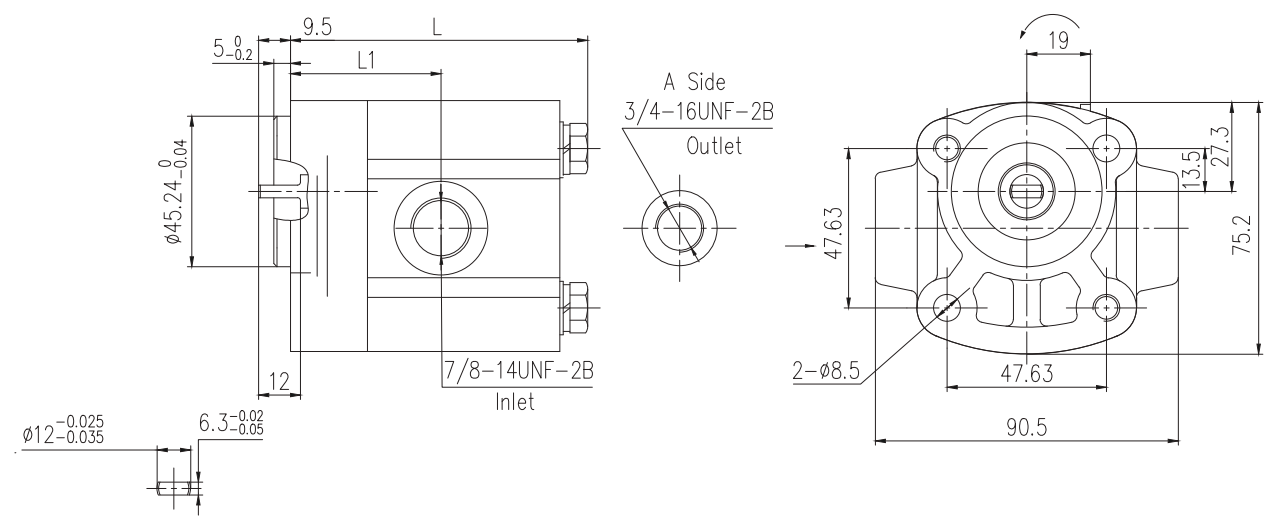

1QCPF**LJ37O31SP5L



1.5 P F 9 F50 F13 S3 L- F- O -V
a | b | c | d | e | f | g | h | i | j | k

- Ⓐ 1.5=Group 1.5
- Ⓑ P=Gear Pump
- Ⓒ Pressure Rate
E=160bar
F=200bar
G=250bar
- Ⓓ Displacement(ml/r)
2, 3, 4, 5, 6, 8, 9, 11, 12
- Ⓔ F50=Line ports
- Ⓕ F13=Drive shafts
- Ⓖ S3=Front covers
- Ⓜ Rotation
R=CW
L=CCW
- Ⓨ Seal
F=FKM Seal
Omit=NBR Seal
- Ⓩ Outboard Bearing
O=Outboard Bearing
Omit=Without Outboard Bearing
- Ⓚ Option
V=Relief valve
D=Check valve

Ⓔ Line ports Inlet/Outlet	Ⓕ Drive shafts	Ⓖ Front covers
F50 25.2x25.2,M6,Ø14.5 25.2x25.2,M6,Ø14.5 	F13 Flat keyed shaft Ø12.5mm x 31.8 	S3 4-hole mounting 63.5x63.5mm 

1.5PF**F**F13S3*



Model	Displacement (ml/r)	Pressure(bar)		Speed(r/min)		
		Rated	Peak	Rated	Max	Min
1.5PF02F50F13S3*	2	210	250	3000	3500	500
1.5PF03F50F13S3*	3	210	250	3000	3500	500
1.5PF04F50F13S3*	4	210	250	3000	3500	500
1.5PF05F50F13S3*	5	210	250	3000	3500	500
1.5PF06F50F13S3*	6	210	250	3000	3500	500
1.5PF08F50F13S3*	8	210	250	3000	3500	500
1.5PF09F50F13S3*	9	175	210	1500	2000	500
1.5PF11F50F13S3*	11	175	210	1500	2000	500
1.5PF12F50F13S3*	12	175	210	1500	2000	500

Dimensions

1.5PF**F50F13S3*

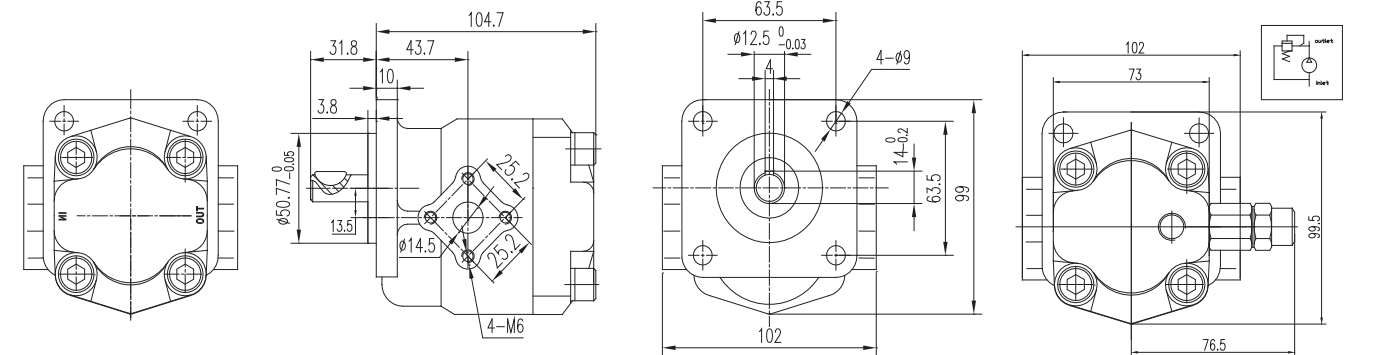

1.5CPF**FL60S92SP7*

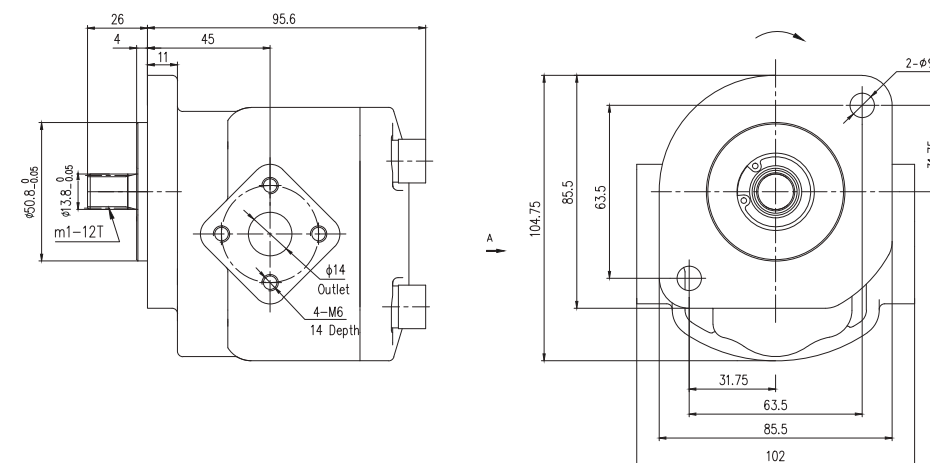

2 * P F 18 L01 F3 O8 L- SS F- O -V
a b c d e f g h i j k l m

- Ⓐ 2=Group 1
- Ⓑ Improve number
Omit=Aluminum covers and body
A=Cast iron covers
AB=Low noise
L=Ultra-low noise
- Ⓒ P=Gear Pump
- Ⓓ Pressure Rate
E=160bar
F=200bar
G=250bar
- Ⓔ Displacement(ml/r)
4, 6, 8, 10, 12, 14, 16, 18, 20, 23, 25, 28, 30
- Ⓕ L01=Line ports
- Ⓖ F3=Drive shafts
- Ⓗ O8=Front covers
- Ⓘ Rotation
R=CW
L=CCW
- Ⓛ B=Bi-directional
- Ⓜ Ports Combination
SS=Side inlet and side outlet
SB=Side inlet and back outlet
BS=Back inlet and Side outlet
BB=Back inlet and back outlet
- Ⓨ Seal F=FKM Seal Omit=NBR Seal
- Ⓩ Outboard Bearing
O=Outboard Bearing
Omit=Without Outboard Bearing
- ⓐ Option V=Relief valve D=Check valve

Ⓕ Line ports Inlet/Outlet	Ⓖ Drive shafts	Ⓗ Front covers
L01 G3/8 Ø9x12.7x1.45mm	F32 Flat keyed shaft SAE A Ø15.88mm	O8 2-through hole mounting 60x60mm
L46 G3/8 G3/8	T3 Tapered key shaft 1:8	S7 4-hole mounting 71.5x96.2mm
L04 G1/2 G1/2	T10 Tapered key shaft 1:5	S8 4-hole mounting 72x100mm
L05 G1/2 G3/8	D4 DIN spline shaft Ø12.7mm x 26mm	D9 2-groove mounting Ø106mm
L69 G3/4 G3/4		D10 2-hole mounting Ø106mm
L03 G1 G3/4		
LJ36 7/8-14UNF-2B 7/8-14UNF-2B		
LJ39 1-1/16-12UN-2B 7/8-14UNF-2B		
F02 Ø30,M6,Ø13 Ø30,M6,Ø13		
F52 Ø40,M6,Ø20 Ø35,M6,Ø15		

2PF **LF32D9***



Model	Displacement (ml/r)	Pressure(bar)		Speed(r/min)			L (mm)	L1 (mm)	Inlet	Outlet
		Rated	Peak	Rated	Max	Min				
2PF4L09F32D9*	4	200	250	2000	3500	500	96	43.3	PT 1/2	PT 1/2
2PF6L09F32D9*	6	200	250	2000	3500	500	98	45		
2PF8L09F32D9*	8	200	250	2000	3500	500	102	46.5		
2PF10L09F32D9*	10	200	250	2000	3500	500	104	48		
2PF12L10F32D9*	12	200	250	2000	3500	500	108	50	PT 3/4	PT 1/2
2PF14L10F32D9*	14	200	250	2000	3500	500	110	51		
2PF16L10F32D9*	16	200	250	2000	3500	500	114	53		
2PF18L10F32D9*	18	200	250	2000	3500	500	117	55		
2PF20L10F32D9*	20	200	250	2000	3500	500	120	56		
2PF23L10F32D9*	23	200	250	2000	3000	500	123	58		
2PF25L10F32D9*	25	200	250	2000	3000	500	128	60		
2PF28L10F32D9*	28	160	200	2000	3000	500	133	63		
2PF30L10F32D9*	30	160	200	2000	3000	500	136	64		

Dimensions

2PF **LF32D9***

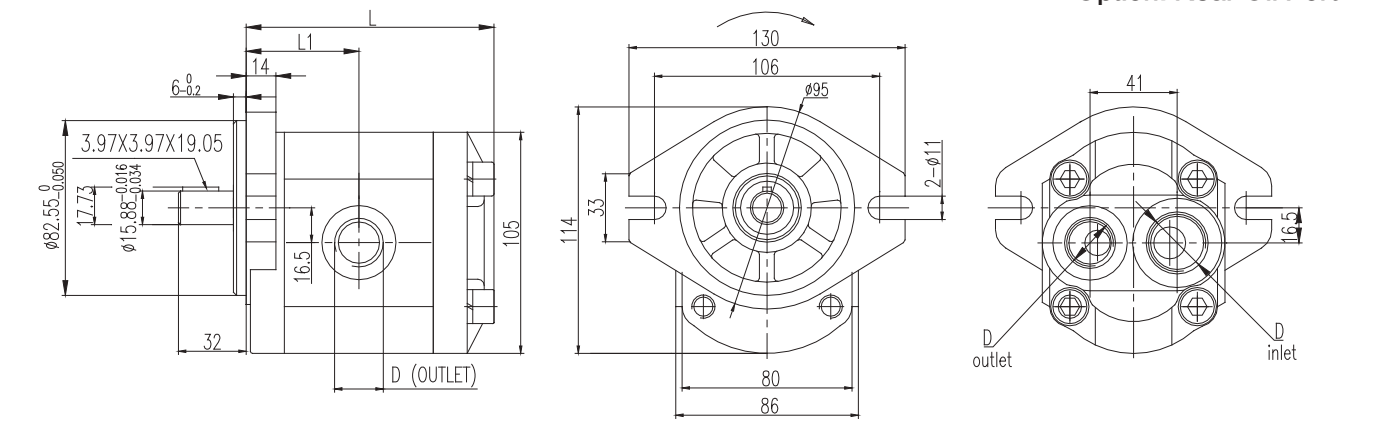

2PFL**S13D9-V**

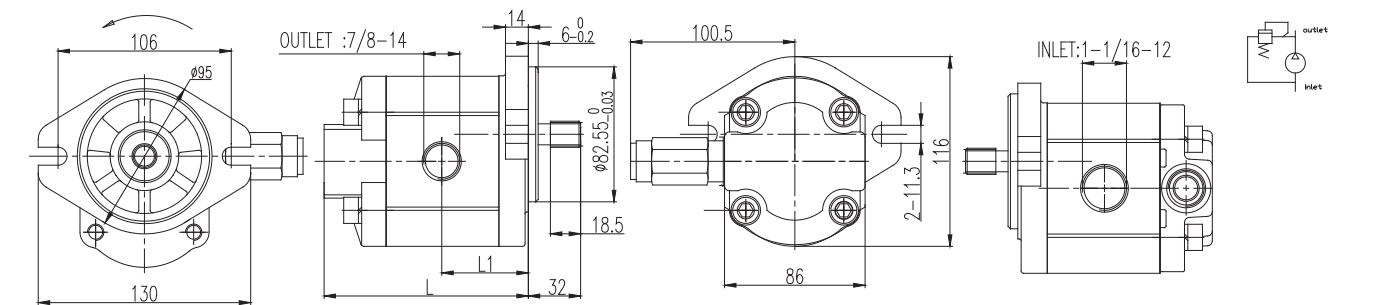

Adjusted Pressure of Relief Valve 50~250 Bar

2ABPFF**T24S7***



2ABPFL**O22D9***



Model	Displacement (ml/r)	Pressure(bar)		Speed(r/min)			L (mm)	L1 (mm)	Inlet			Outlet		
		Rated	Peak	Rated	Max	Min			ØD1	Ød1	T1	ØD2	Ød2	T2
2ABPF4F02T24S7*	4	200	250	2000	3500	500	95.5	43.3	30	13	M6	ØD2	Ød2	T2
2ABPF6F02T24S7*	6	200	250	2000	3500	500	99	45						
2ABPF8F02T24S7*	8	200	250	2000	3500	500	102	46.5						
2ABPF10F06T24S7*	10	200	250	2000	3500	500	105	48						
2ABPF12F06T24S7*	12	200	250	2000	3500	500	108	49.5						
2ABPF14F06T24S7*	14	200	250	2000	3500	500	111	51						
2ABPF16F06T24S7*	16	200	250	2000	3500	500	114	52.5						
2ABPF18F06T24S7*	18	200	250	2000	3500	500	117.5	54.3	40	20	M8	3	13	M6
2ABPF20F06T24S7*	20	200	250	2000	3500	500	121	56						
2ABPF23F06T24S7*	23	200	250	2000	3000	500	125.5	58.3						
2ABPF25F06T24S7*	25	200	250	2000	3000	500	128	59.5						
2ABPF28F06T24S7*	28	160	200	2000	3000	500	133	62						
2ABPF30F06T24S7*	30	160	200	2000	3000	500	136	63.5						

Model	Displacement (ml/r)	Pressure(bar)		Speed(r/min)			L (mm)	L1 (mm)	Inlet	Outlet
		Rated	Peak	Rated	Max	Min				
2ABPF04LJ52O22D9*	4	200	250	2000	3500	500	96	43.3	1-1/16-12UN-2B	3/4-16UNF-2B
2ABPF06LJ52O22D9*	6	200	250	2000	3500	500	98	45		
2ABPF08LJ52O22D9*	8	200	250	2000	3500	500	102	46.5		
2ABPF10LJ52O22D9*	10	200	250	2000	3500	500	104	48		
2ABPF12LJ52O22D9*	12	200	250	2000	3500	500	108	50		
2ABPF14LJ52O22D9*	14	200	250	2000	3500	500	110	51		
2ABPF16LJ52O22D9*	16	200	250	2000	3500	500	114	53		
2ABPF18LJ52O22D9*	18	200	250	2000	3500	500	117	55		
2ABPF20LJ52O22D9*	20	200	250	2000	3500	500	120	56		
2ABPF23LJ52O22D9*	23	200	250	2000	3000	500	123	58		
2ABPF25LJ52O22D9*	25	200	250	2000	3000	500	128	60		
2ABPF28LJ52O22D9*	28	160	200	2000	3000	500	133	63		
2ABPF30LJ52O22D9*	30	160	200	2000	3000	500	136	64		

Dimensions

2ABPFF06T24S7***

Option: With Relief Valve

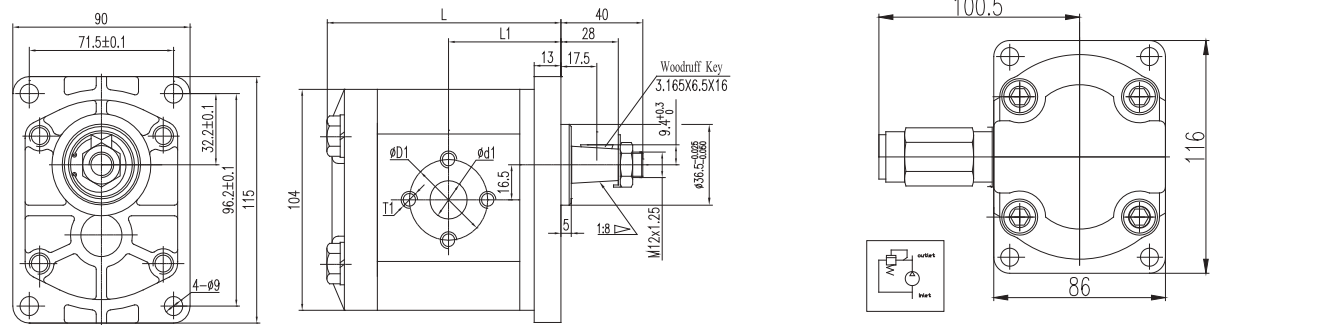

2ABPFT49SP8L**

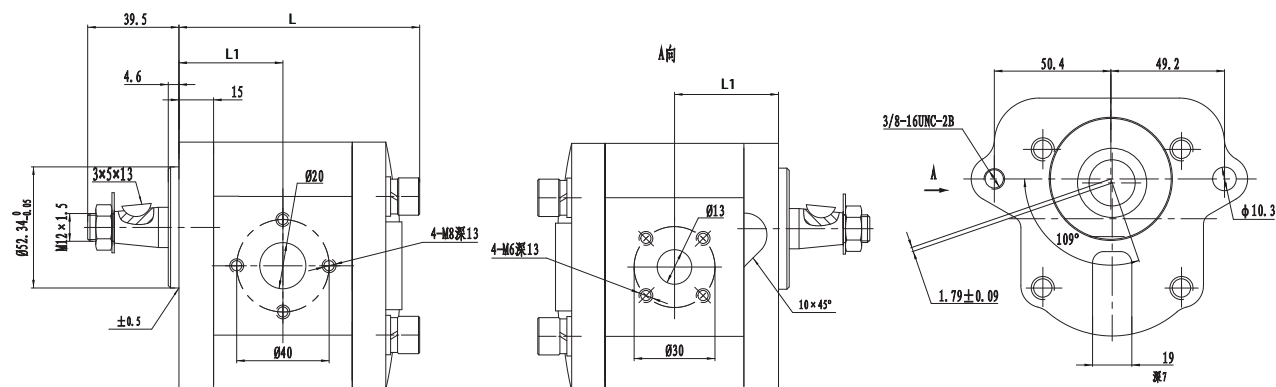

Dimensions

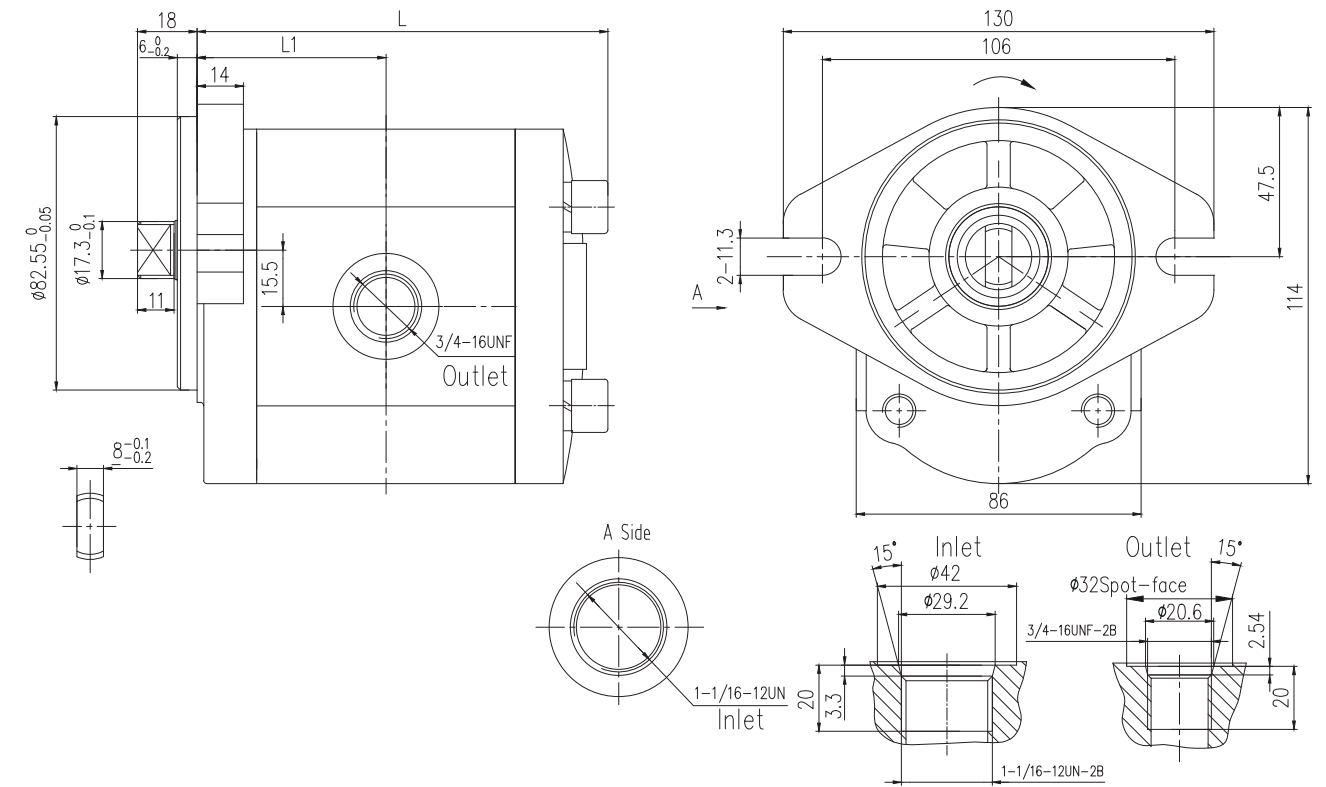

2LPFF**T31S7***



Model	Displacement (ml/r)	Pressure(bar)		Speed(r/min)			L (mm)	L1 (mm)
		Rated	Peak	Rated	Max	Min		
2LPF04F52T31S7*	4	200	230	1500	1800	1000	95.5	42
2LPF06F52T31S7*	6	200	230	1500	1800	1000	99	43.8
2LPF08F52T31S7*	8	200	230	1500	1800	1000	103	45.8
2LPF10F52T31S7*	10	200	230	1500	1800	1000	107	47.8
2LPF12F52T31S7*	12	200	230	1500	1800	1000	111	49.8
2LPF14F52T31S7*	14	200	230	1500	1800	1000	115	51.8
2LPF16F52T31S7*	16	200	230	1500	1800	1000	118.5	53.5
2LPF18F52T31S7*	18	200	230	1500	1800	1000	122.5	55.5
2LPF19F52T31S7*	19	180	210	1500	1800	1000	124.5	56.5
2LPF20F52T31S7*	20	180	210	1500	1800	1000	126.5	57.5
2LPF23F52T31S7*	23	180	210	1500	1800	1000	132.5	60.5
2LPF25F52T31S7*	25	160	180	1500	1800	1000	136	62.3
2LPF28F52T31S7*	28	160	180	1500	1800	1000	142	65.3
2LPF28F52T31S7*	30	160	180	1500	1800	1000	146	67.3

Dimensions

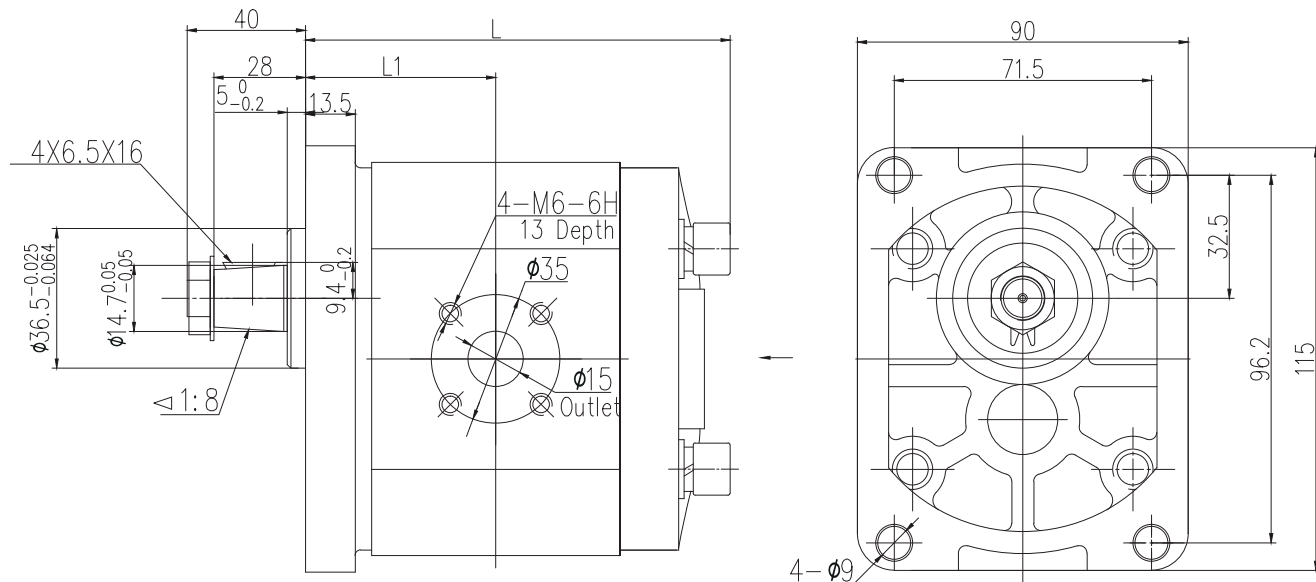

2APFF**T20O8***



Model	Displacement (ml/r)	Pressure(bar)		Speed(r/min)			L (mm)	L1 (mm)	Inlet			Outlet		
		Rated	Peak	Rated	Max	Min			ØD1	Ød1	T1	ØD2	Ød2	T2
2APF4F60T20O8*	4	200	250	2000	3500	500	95.5	43.3	40	15	M6	35	15	M6
2APF6F60T20O8*	6	200	250	2000	3500	500	99	45						
2APF8F52T20O8*	8	200	250	2000	3500	500	102	46.5	40	20	M6	35	15	M6
2APF10F52T20O8*	10	200	250	2000	3500	500	105	48						
2APF12F52T20O8*	12	200	250	2000	3500	500	108	49.5						
2APF14F52T20O8*	14	200	250	2000	3500	500	111	51						
2APF16F52T20O8*	16	200	250	2000	3500	500	114	52.5						
2APF18F52T20O8*	18	200	250	2000	3500	500	117.5	54.3						
2APF20F52T20O8*	20	200	250	2000	3500	500	121	56						
2APF23F52T20O8*	23	200	250	2000	3000	500	125.5	58.3						
2APF25F52T20O8*	25	200	250	2000	3000	500	128	59.5						
2APF28F52T20O8*	28	160	200	2000	3000	500	133	62						
2APF30F52T20O8*	30	160	200	2000	3000	500	136	63.5						

Dimensions

2APFF52T20O8***

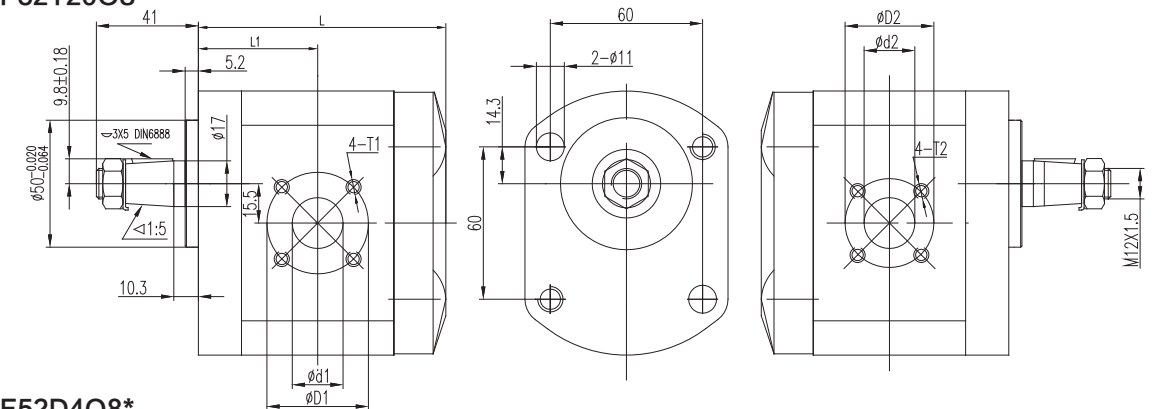

2APFF52D4O8***

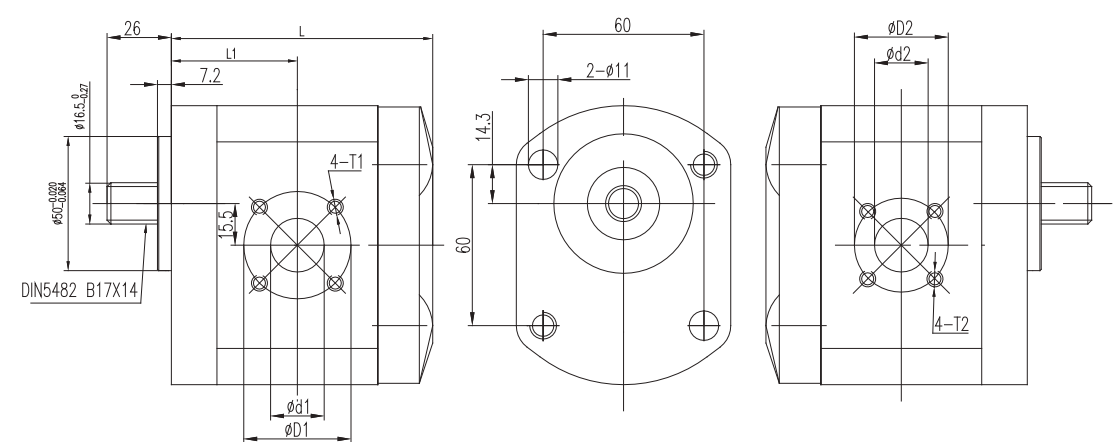

2APFF**T21SP1***



2APFF**T10S8***



Model	Displacement (ml/r)	Pressure(bar)		Speed(r/min)			L (mm)	L1 (mm)	Inlet			Outlet
		Rated	Peak	Rated	Max	Min			ØD1	Ød1	T1	
2APF4LF5T21SP1*	4	200	250	2000	3500	500	91.5	42.3	40	19	M6	G3/8
2APF6LF5T21SP1*	6	200	250	2000	3500	500	95	44				
2APF8LF5T21SP1*	8	200	250	2000	3500	500	98	45.5				
2APF10LF5T21SP1*	10	200	250	2000	3500	500	101	47				
2APF12LF5T21SP1*	12	200	250	2000	3500	500	104.5	48.8				
2APF14LF5T21SP1*	14	200	250	2000	3500	500	107.5	50				
2APF16LF5T21SP1*	16	200	250	2000	3500	500	111	52				
2APF18LF5T21SP1*	18	200	250	2000	3500	500	114	54				
2APF20LF5T21SP1*	20	200	250	2000	3500	500	118	55				
2APF23LF5T21SP1*	23	200	250	2000	3500	500	122	58				
2APF25LF5T21SP1*	25	200	250	2000	3500	500	125	59				
2APF28LF5T21SP1*	28	160	200	2000	3500	500	130	61				
2APF30LF5T21SP1*	30	160	200	2000	3500	500	133	63				

Model	Displacement (ml/r)	Pressure(bar)		Speed(r/min)			L (mm)	L1 (mm)	Inlet			Outlet		
		Rated	Peak	Rated	Max	Min			ØD1	Ød1	T1	ØD2	Ød2	T2
2APF4F60T10S8*	4	200	250	2000	3500	500	95.5	43.3	40	15	M6	35	15	M6
2APF6F60T10S8*	6	200	250	2000	3500	500	99	45						
2APF8F52T10S8*	8	200	250	2000	3500	500	102	46.5						
2APF10F52T10S8*	10	200	250	2000	3500	500	105	48						
2APF12F52T10S8*	12	200	250	2000	3500	500	108	49.5						
2APF14F52T10S8*	14	200	250	2000	3500	500	111	51						
2APF16F52T10S8*	16	200	250	2000	3500	500	114	52.5						
2APF18F52T10S8*	18	200	250	2000	3500	500	117.5	54.3						
2APF20F52T10S8*	20	200	250	2000	3500	500	121	56						
2APF23F52T10S8*	23	200	250	2000	3000	500	125.5	58.3						
2APF25F52T10S8*	25	200	250	2000	3000	500	128	59.5						
2APF28F52T10S8*	28	160	200	2000	3000	500	133	62						
2APF30F52T10S8*	30	160	200	2000	3000	500	136	63.5						

Dimensions

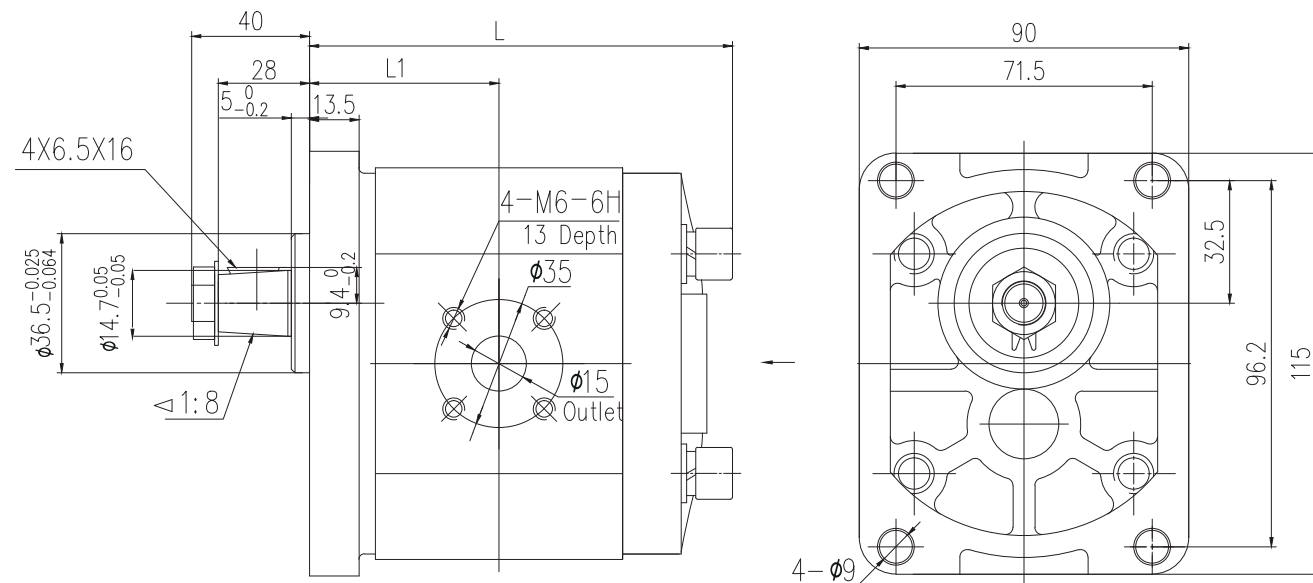

Dimensions

2APFF52T10S8***

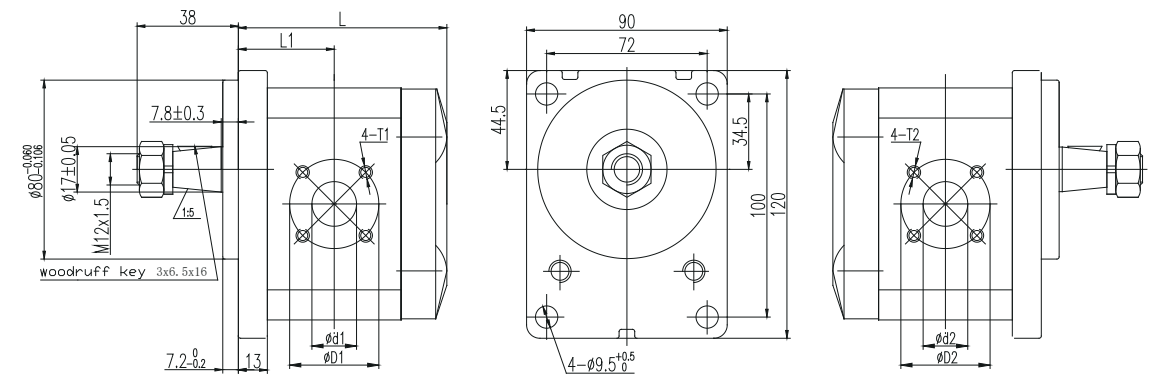

2APFF52T37S9***

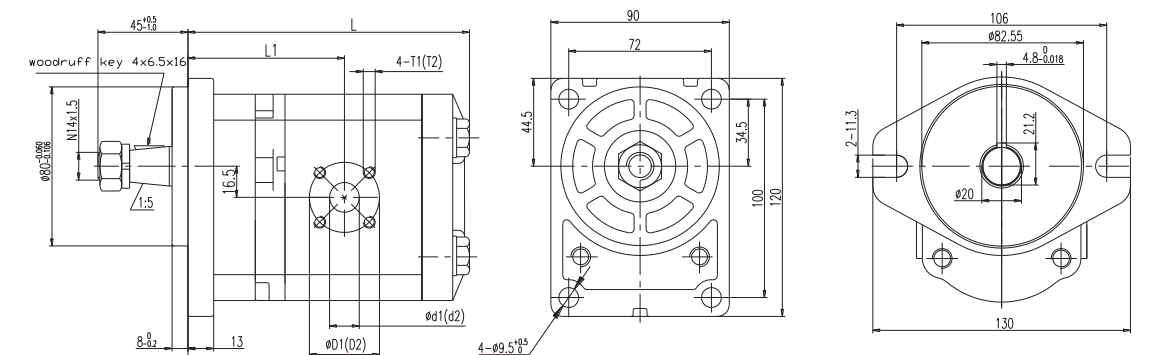

Option: 2PF**F**P21*-O

2.5 A P F 30 L04 T10 D9 L- SS F- O -V
a b c d e f g h i j k l m

- Ⓐ 2.5=Group 2.5
- Ⓑ Improve number
Omit=Aluminum covers and body
C=Forklift pump
Q=Ceramic forklift pump
- Ⓒ P=Gear Pump
- Ⓓ Pressure Rate
E=160bar
F=200bar
G=250bar
- Ⓔ Displacement(ml/r)
20、25、27、30、32、36、40
- Ⓕ L04=Line ports
- Ⓖ T10=Drive shafts
- Ⓗ D9=Front covers
- Ⓘ Rotation
R=CW
L=CCW
B=Bi-directional
- Ⓚ Ports Combination
SS=Side inlet and side outlet
SB=Side inlet and back outlet
BS=Back inlet and Side outlet
BB=Back inlet and back outlet
- Ⓛ Seal
F=FKM Seal
Omit=NBR Seal
- Ⓛ Outboard Bearing
O=Outboard Bearing
Omit=Without Outboard Bearing
- Ⓜ Option
V=Relief valve
D=Check valve

Ⓕ Line ports Inlet/Outlet	Ⓖ Drive shafts	Ⓗ Front covers
L04 G1/2 G1/2	F63 Flat keyed shaft SAE A Ø15.88mm	D9 2-groove mounting Ø106mm
L69 G3/4 G3/4	T3 Tapered key shaft 1:8	SP9 2-groove mounting Ø106mm
L03 G1 G3/4	T10 Tapered key shaft 1:5	
LJ36 7/8-14UNF-2B 7/8-14UNF-2B	S46 Splined shaft 11teeth 18.63mm	
LJ39 1-1/16-12UN-2B 7/8-14UNF-2B	S28 Splined shaft 10teeth 16.95mm	
F30 52.4*26.2,M10,Ø25 47.6*22.2,M10,Ø19		
F77 30.2*58.7,M10,Ø25 26.2*52.4,M10,Ø19		

2.5APF **LF63D9***



Model	Displacement (ml/r)	Pressure(bar)		Speed(r/min)			L (mm)	L1 (mm)	Inlet	Outlet
		Rated	Peak	Rated	Max	Min				
2.5APF20L03F63D9*	20	200	250	2000	3000	500	124.5	61.5	G 1	G 3/4
2.5APF25L03F63D9*	25	200	250	2000	3000	500	130.5	64.5		
2.5APF27L03F63D9*	27	200	250	2000	3000	500	133	65.8		
2.5APF30L03F63D9*	30	200	250	2000	3000	500	136.5	67.5		
2.5APF32L03F63D9*	32	200	230	2000	3000	500	139	68.8		
2.5APF36L03F63D9*	36	200	230	2000	3000	500	143.5	71		
2.5APF40L03F63D9*	40	160	200	2000	3000	500	148.5	73.5		

Dimensions

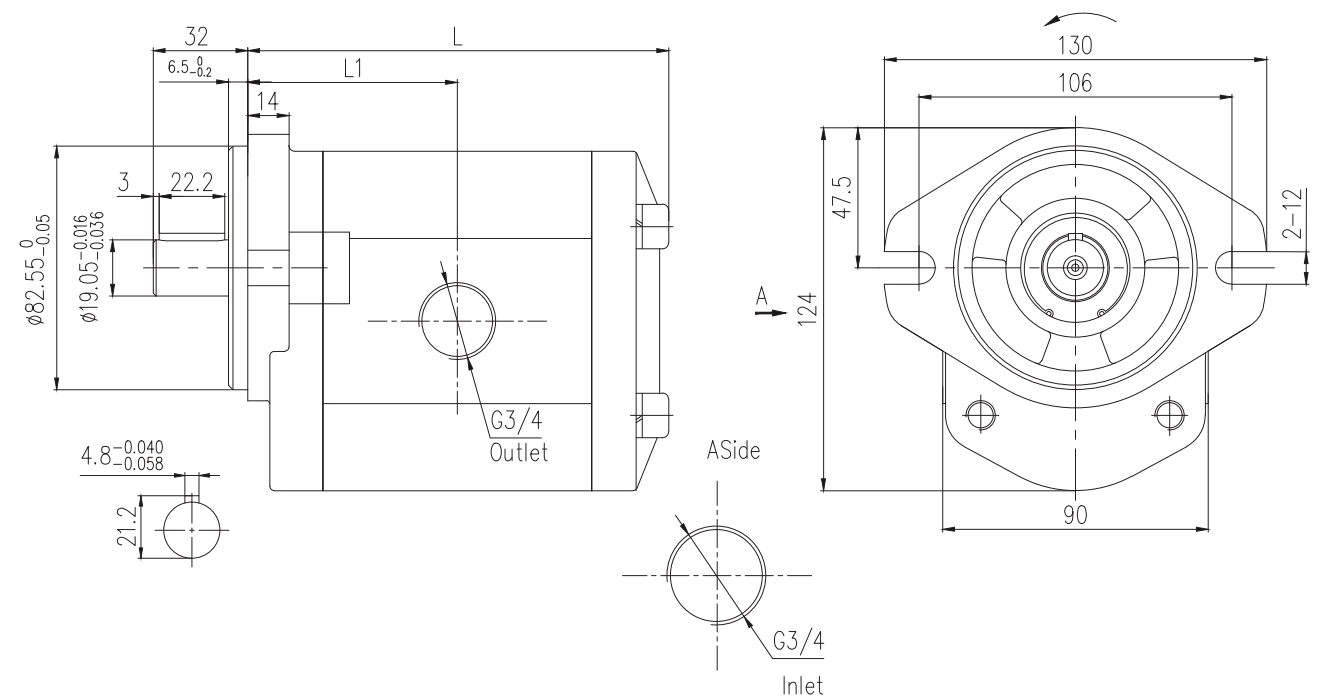

2.5CPF **FS28SP9***

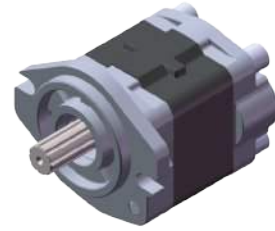

Model	Displacement (ml/r)	Pressure(bar)		Speed(r/min)			L (mm)	L1 (mm)	Inlet	Outlet
		Rated	Peak	Rated	Max	Min				
2.5CPF20F30S28SP9*	20	200	250	2000	3000	500	124.5	61.5	Ø 25	Ø 19
2.5CPF25F30S28SP9*	25	200	250	2000	3000	500	130.5	64.5		
2.5CPF27F30S28SP9*	27	200	250	2000	3000	500	133	65.8		
2.5CPF30F30S28SP9*	30	200	250	2000	3000	500	136.5	67.5		
2.5CPF32F30S28SP9*	32	200	230	2000	3000	500	139	68.8		
2.5CPF36F30S28SP9*	36	200	230	2000	3000	500	143.5	71		
2.5CPF40F30S28SP9*	40	160	200	2000	3000	500	148.5	73.5		

Dimensions

2.5CPFF30S28SP9***

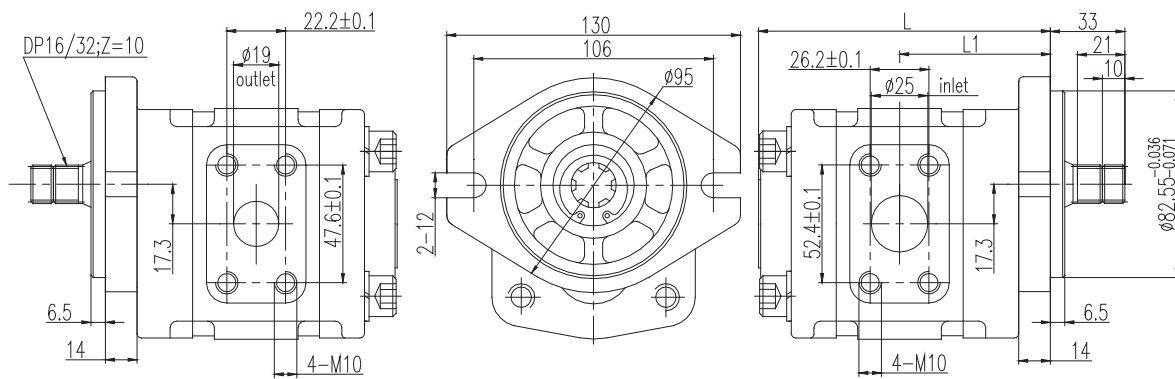

2.5CPFLJ03F88SP9LBB**

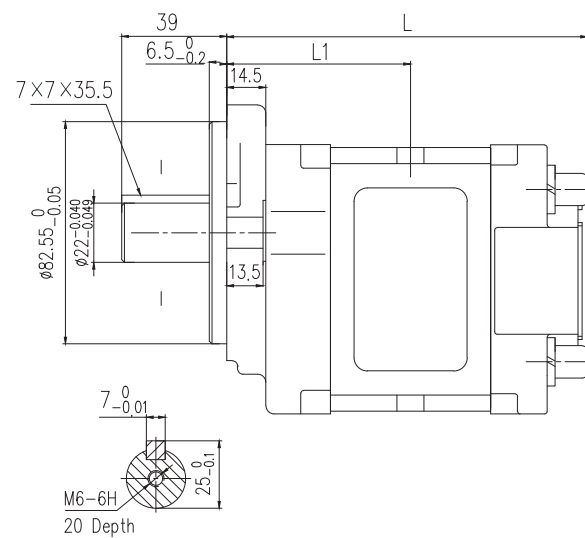

Option :2.5CPFLJ02S28SP9*BB**

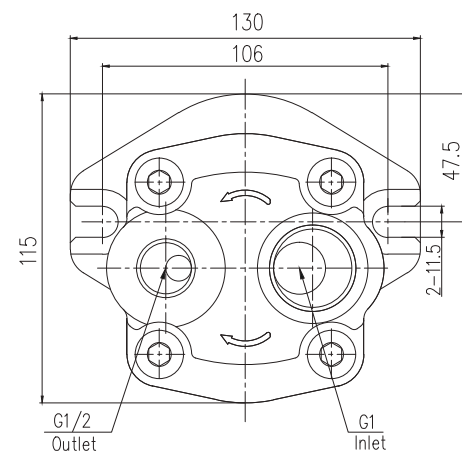

2.5QPF **LJ03S65SP9LBB



Model	Displacement (ml/r)	Pressure(bar)		Speed(r/min)			L (mm)	Inlet	Outlet
		Rated	Peak	Rated	Max	Min			
2.5QPF16LJ03S65SP9LBB	16	200	250	1500	2500	500	101.5	G 1	G 3/4
2.5QPF18LJ03S65SP9LBB	18	200	250	1500	2500	500	103.5		
2.5QPF20LJ03S65SP9LBB	20	200	250	1500	2500	500	105.5		
2.5QPF23LJ03S65SP9LBB	23	200	250	1500	2500	500	108.5		
2.5QPF25LJ03S65SP9LBB	25	200	250	1500	2500	500	110.5		
2.5QPF28LJ03S65SP9LBB	28	200	250	1500	2500	500	113.5		
2.5QPF30LJ03S65SP9LBB	30	200	250	1500	2500	500	115.5		
2.5QPF32LJ03S65SP9LBB	32	200	250	1500	2500	500	117.5		
2.5QPF36LJ03S65SP9LBB	36	200	250	1500	2500	500	121.5		
2.5QPF40LJ03S65SP9LBB	40	200	250	1500	2500	500	125.5		
2.5QPF45LJ03S65SP9LBB	45	200	250	1500	2500	500	130.5		
2.5QPF52LJ03S65SP9LBB	52	200	250	1500	2500	500	137.5		

Dimensions

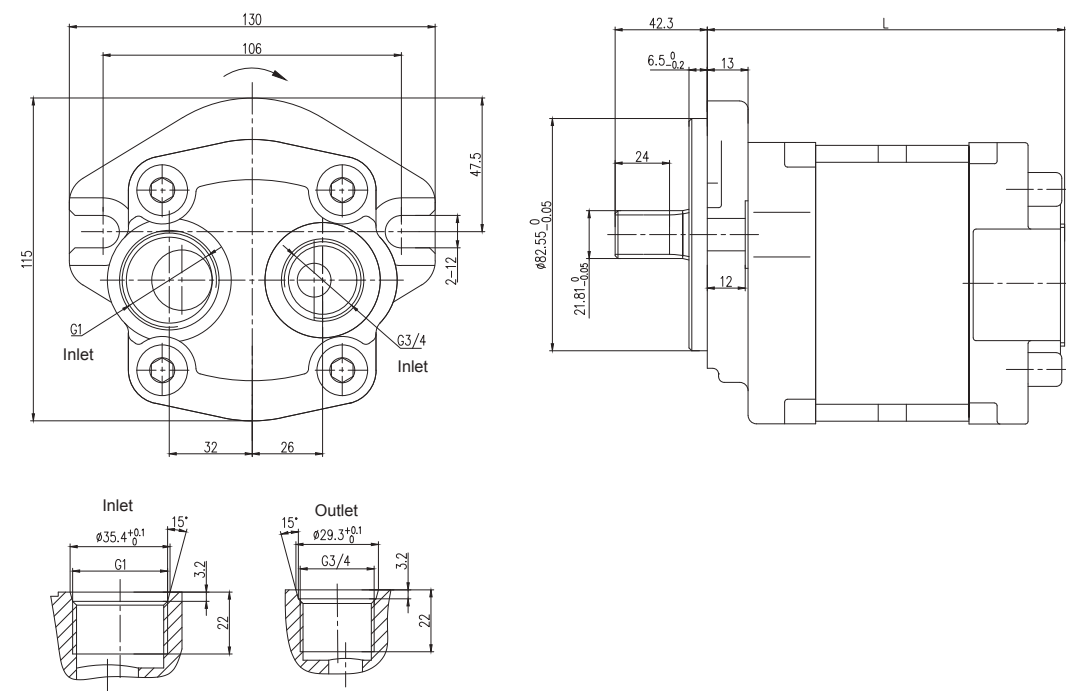

2.8 A P F 40 L69 S71 D16 L- SS F- O -V
a | b | c | d | e | f | g | h | i | j | k | l | m

- Ⓐ 2.8=Group 2.8
- Ⓑ Improve number
A=Cast iron covers
- Ⓒ P=Gear Pump
- Ⓓ Pressure Rate
E=160bar
F=200bar
G=250bar
- Ⓔ Displacement(ml/r)
6、8、10、12、14、16、19、22、25、
28、30、32、36、40、43、45
- Ⓕ L69=Line ports
- Ⓖ S71=Drive shafts
- Ⓗ D16=Front covers
- Ⓘ Rotation
R=CW
L=CCW
- Ⓛ B=Bi-directional
- Ⓜ Ports Combination
- Ⓝ Seal
F=FKM Seal
Omit=NBR Seal
- Ⓟ Outboard Bearing
O=Outboard Bearing
Omit=Without Outboard Bearing
- Ⓠ Option
V=Relief valve
D=Check valve

Ⓕ Line ports Inlet/Outlet	Ⓖ Drive shafts	Ⓗ Front covers
L04 G1/2 G1/2	S71 Splined shaft 13teeth 21.81mm	D16 2-hole mounting Ø146mm
L05 G1/2 G3/8		
L69 G3/4 G3/4		
L03 G1 G3/4		
LJ36 7/8-14UNF-2B 7/8-14UNF-2B		
LJ39 1-1/16-12UN-2B 7/8-14UNF-2B		

2.8APF**LJ**S71D16L



Model	Displacement (ml/r)	Pressure(bar)		Speed(r/min)			L (mm)
		Rated	Peak	Rated	Max	Min	
2.8APF06LJ39S71D16L	06	250	280	2000	4000	800	115
2.8APF08LJ39S71D16L	08	250	280	2000	4000	800	117
2.8APF10LJ39S71D16L	10	250	280	2000	4000	700	119
2.8APF12LJ39S71D16L	12	250	280	2000	3500	700	121.5
2.8APF14LJ39S71D16L	14	250	280	2000	3500	600	123.5
2.8APF16LJ39S71D16L	16	250	280	2000	3500	600	125.5
2.8APF19LJ39S71D16L	19	250	280	2000	3000	500	128.5
2.8APF22LJ39S71D16L	22	250	280	2000	3000	500	132
2.8APF25LJ39S71D16L	25	250	280	2000	3000	500	135
2.8APF28LJ39S71D16L	28	250	280	2000	3000	500	138.5
2.8APF30LJ39S71D16L	30	230	250	2000	3000	500	140.5
2.8APF32LJ39S71D16L	32	230	250	2000	3000	400	142.5
2.8APF36LJ39S71D16L	36	200	230	1500	2750	400	147
2.8APF40LJ39S71D16L	40	200	230	1500	2750	400	151.5
2.8APF43LJ39S71D16L	43	170	190	1500	2500	400	154.5
2.8APF45LJ39S71D16L	45	170	190	1500	2500	400	156.5

Dimensions

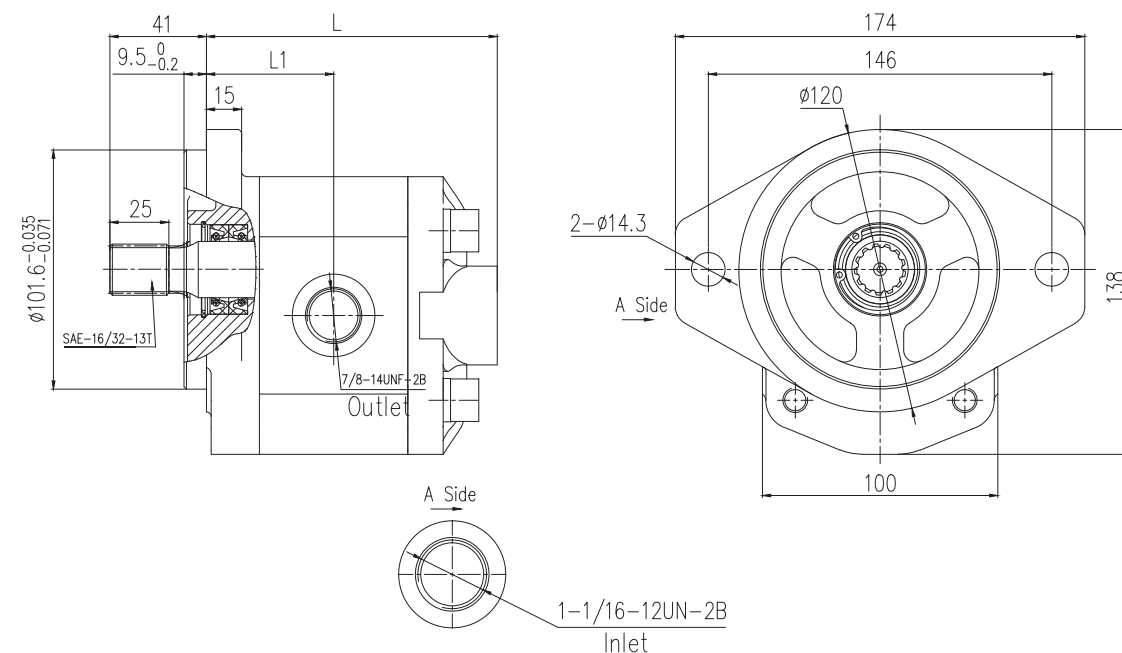



3APF**F**T11S12*

3	A	P	F	60	L99	S71	D16	L-	SS	F-	O	-v
a	b	c	d	e	f	g	h	i	j	k	l	m

- Ⓐ 3=Group 3
- Ⓑ Improve number
A=Cast iron covers
B=Special type
- Ⓒ P=Gear Pump
- Ⓓ Pressure Rate
E=160bar
F=200bar
G=250bar
- Ⓔ Displacement(ml/r)
22、26、34、39、43、51、60、70、78、89
- Ⓕ L99=Line ports
- Ⓖ S71=Drive shafts
- Ⓗ D16=Front covers
- Ⓘ Rotation
R=CW
L=CCW
B=Bi-directional
- Ⓚ Ports Combination
SS=Side inlet and side outlet
SB=Side inlet and back outlet
BS=Back inlet and Side outlet
BB=Back inlet and back outlet
- Ⓛ Seal
F=FKM Seal
Omit=NBR Seal
- Ⓛ Outboard Bearing
O=Outboard Bearing
Omit=Without Outboard Bearing
- Ⓜ Option
V=Relief valve
D=Check valve

Ⓕ Line ports Inlet/Outlet	Ⓖ Drive shafts	Ⓗ Front covers
L69 G3/4 G3/4	T11 Tapered key shaft 1:8	S12 4-hole mounting 98.5x128mm
L03 G1 G3/4	S71 Splined shaft 13teeth 21.81mm	D16 2-hole mounting Ø146mm
L11 G1-1/4 G1		D12 2-hole mounting Ø146mm
L99 G1-1/4 G1-1/4		
LJ42 1-5/16-12UN-2B 1-1/16-12UN-2B		
LJ53 1-5/8-12UN-2B 1-5/16-12UN-2B		
F10 Ø56 ,M10,Ø27 Ø56 ,M10,Ø19		

Model	Displacement (ml/r)	Pressure(bar)		Speed(r/min)			L (mm)	L1 (mm)	ØD1	Ød1	T1	ØD2	Ød2	T2
		Rated	Peak	Rated	Max	Min								
3APF22F10T11S12	22	200	250	2000	3000	400	128.5	65.5	56	27	M10	56	19	M10
3APF26F10T11S12	26	200	250	2000	3000	400	131.5	67						
3APF34F10T11S12	34	200	250	2000	3000	400	137	69.8						
3APF39F10T11S12	39	200	250	2000	3000	400	141	71.8						
3APF43F09T11S12	43	200	250	2000	2800	400	143.5	73	51	27	51	27	M10	
3APF51F11T11S12	51	200	250	2000	2400	400	149.5	76	56	27				
3APF60F12T11S12	60	180	230	1500	2800	400	156	79.3	62	33	51	27	M10	
3APF70F12T11S12	70	180	200	1500	2500	400	163	82.8						
3APF78F12T11S12	78	160	200	1500	2300	400	169.2	85.2						
3APF89F12T11S12	89	140	180	1500	2000	400	174.2	88.2						

Dimensions

3APF**F**T11S12*

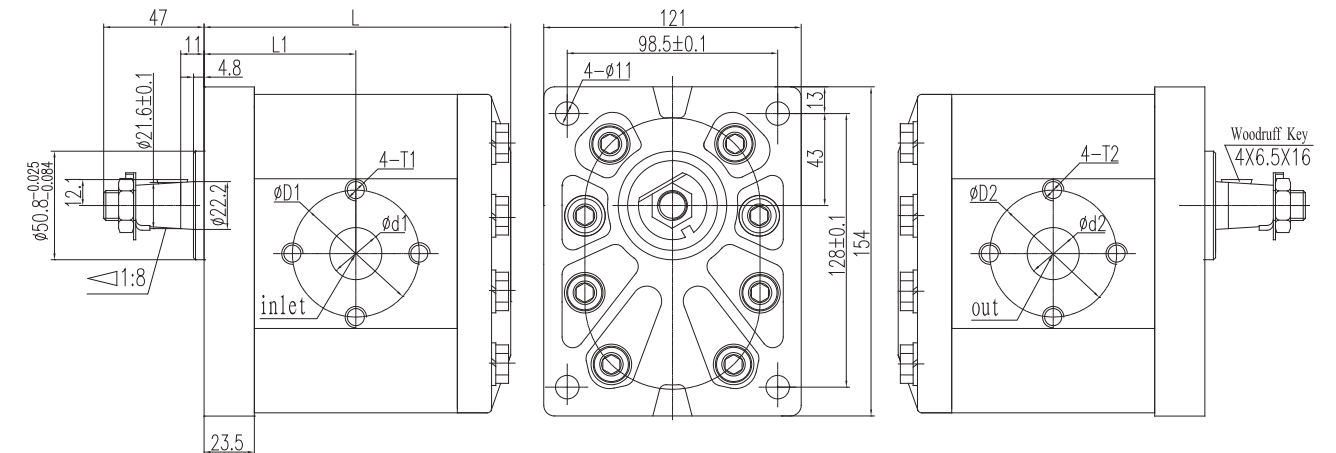

3APF**F12T47S18L

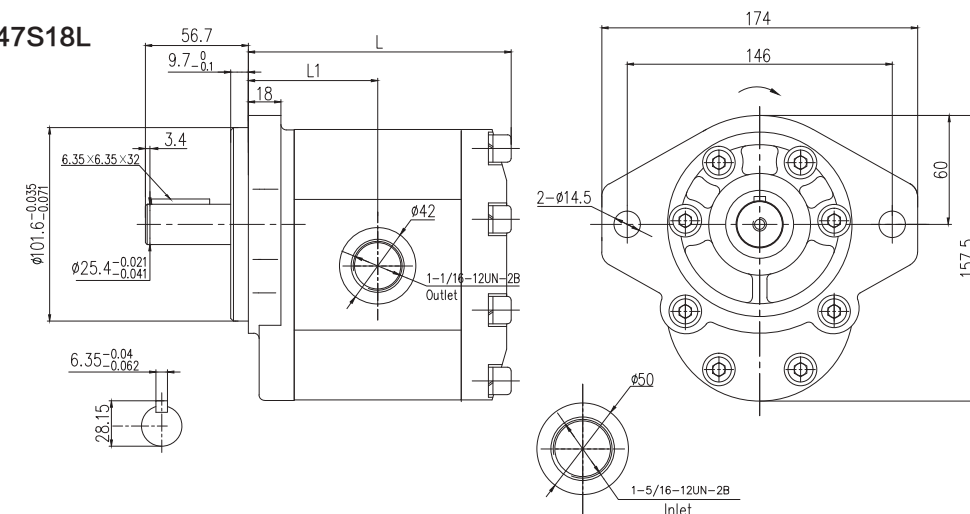

3APF**F32S70D12*



Model	Displacement (ml/r)	Pressure(bar)		Speed(r/min)			L (mm)	L1 (mm)	L2 (mm)	B2 (mm)	∅D1 (mm)	T1 (mm)	L3 (mm)	B3 (mm)	∅D2 (mm)	T2 (mm)
		Rated	Peak	Rated	Max	Min										
3APF22F32S70D12	22	200	250	2000	3000	400	130.3	65.3	52.4	26.2	27	16UNC -2B	26.2	47.6	19	16UNC -2B
3APF26F32S70D12	26	200	250	2000	3000	400	133.3	66.8								
3APF34F32S70D12	34	200	250	2000	3000	400	138.8	69.6								
3APF39F32S70D12	39	200	250	2000	3000	400	142.8	71.6								
3APF43F32S70D12	43	200	250	2000	2800	400	145.3	72.8								
3APF51F32S70D12	51	200	250	2000	2400	400	151.3	75.8								
3APF60F36S70D12	60	180	230	1500	2800	400	157.8	79.1	58.7	28.4	33	7/16 14UNC -2B	26.2	52.4	27	
3APF70F36S70D12	70	180	200	1500	2500	400	164.8	82.5								
3APF78F36S70D12	78	160	200	1500	2300	400	171	85								
3APF89F36S70D12	89	140	180	1500	2000	400	176	88								

Dimensions

3APF**F**S70D12*

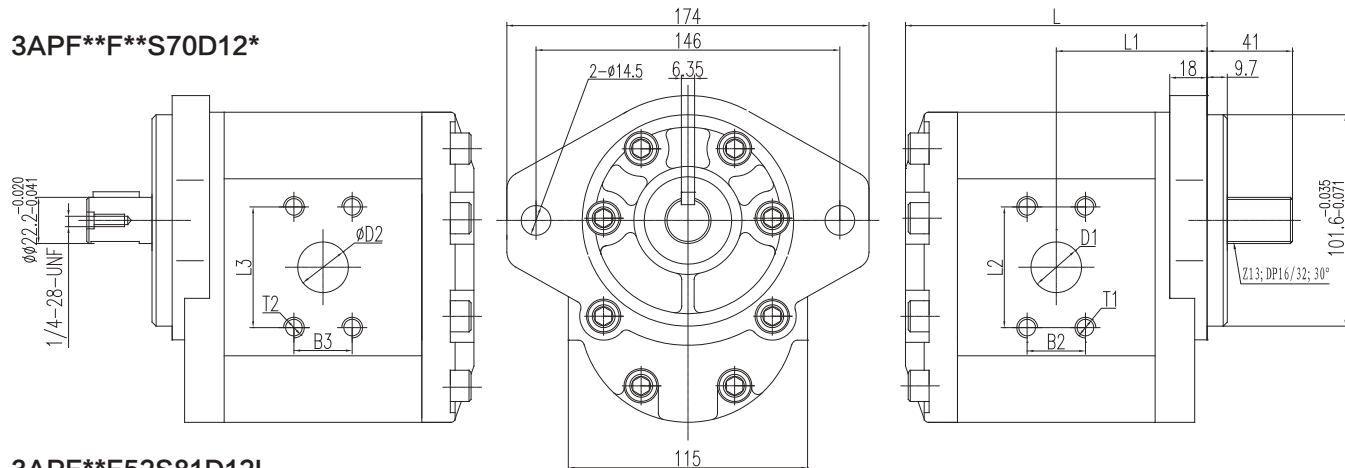

3APF**F52S81D12L

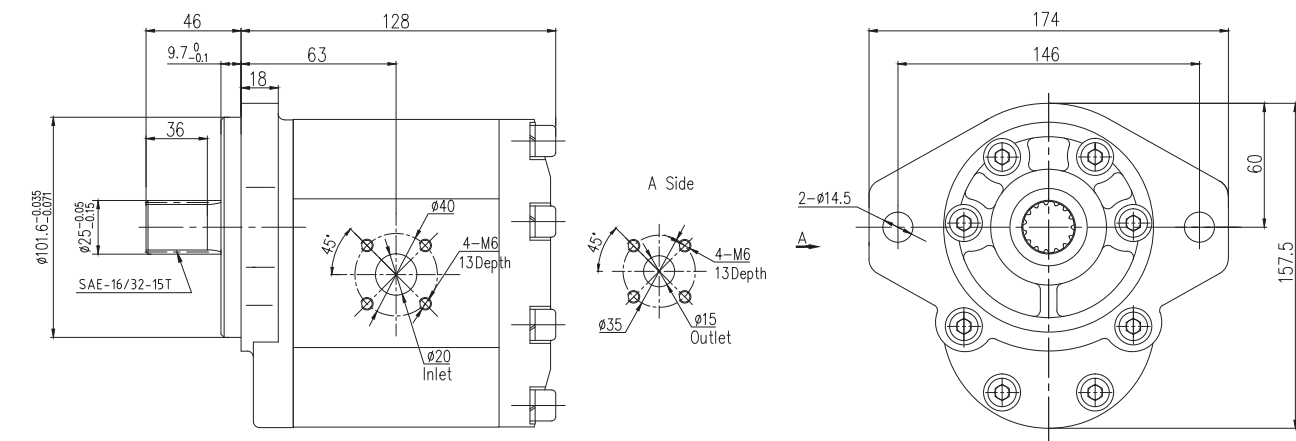

3APF**F**F12D9*



Model	Displacement (ml/r)	Pressure(bar)		Speed(r/min)			L (mm)	L1 (mm)	L2 (mm)	B2 (mm)	∅D1 (mm)	T1 (mm)	L3 (mm)	B3 (mm)	∅D2 (mm)	T2 (mm)
		Rated	Peak	Rated	Max	Min										
3APF22F32F12D9*	22	200	250	2000	3000	400	130.3	65.3	52.4	26.2	27	16UNC -2B	26.2	47.6	19	
3APF26F32F12D9*	26	200	250	2000	3000	400	133.3	66.8								
3APF34F32F12D9*	34	200	250	2000	3000	400	138.8	69.6								
3APF39F32F12D9*	39	200	250	2000	3000	400	142.8	71.6								
3APF43F32F12D9*	43	200	250	2000	2800	400	145.3	72.8								
3APF51F32F12D9*	51	200	250	2000	2400	400	151.3	75.8								
3APF60F36F12D9*	60	180	230	1500	2800	400	157.8	79.1	58.7	28.4	33	7/16 14UNC -2B	26.2	52.4	27	
3APF70F36F12D9*	70	180	200	1500	2500	400	164.8	82.5								
3APF78F36F12D9*	78	160	200	1500	2300	400	171	85								
3APF89F36F12D9*	89	140	180	1500	2000	400	176	88								

Dimensions

3APF**F**F12D9*

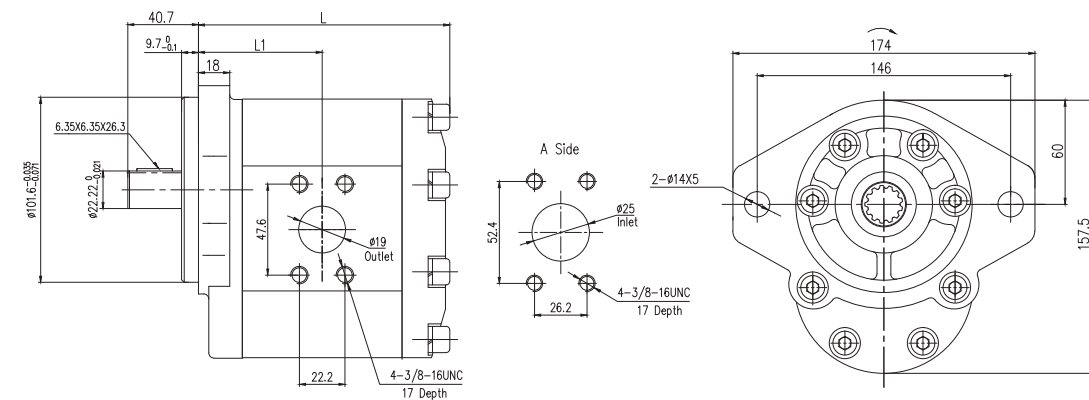

3APF LJ42F100D12

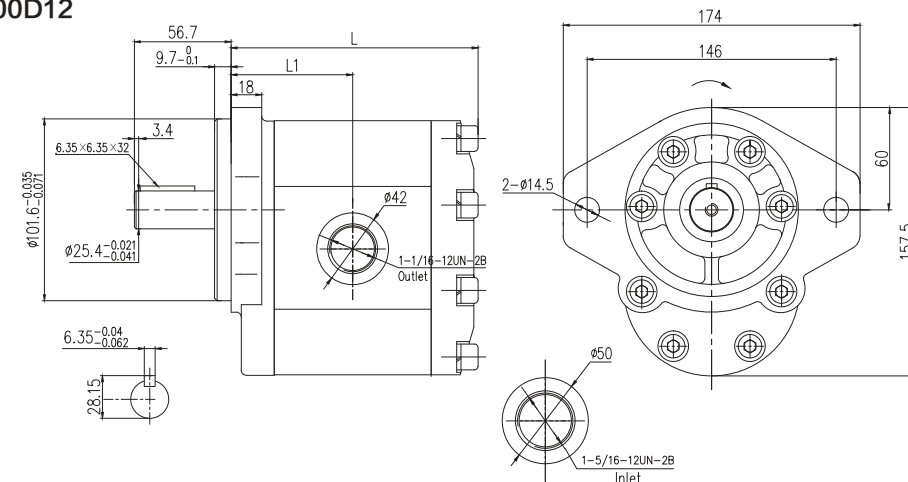

3BPFLJ**S70SP10***



Model	Displacement (ml/r)	Pressure(bar)		Speed(r/min)			L (mm)	L1 (mm)	T1 (mm)	T2 (mm)
		Rated	Peak	Rated	Max	Min				
3BPF22LJ53S70SP10*	22	200	250	2000	3000	400	111.6	85.6	1-5/8-12UNC-2B	1-5/16-12UNC-2B
3BPF26LJ53S70SP10*	26	200	250	2000	3000	400	114.5	88.5		
3BPF34LJ53S70SP10*	34	200	250	2000	3000	400	120.2	94.2		
3BPF39LJ53S70SP10*	39	200	250	2000	3000	400	123.8	97.8		
3BPF43LJ53S70SP10*	43	200	250	2000	2800	400	126.5	100.5		
3BPF50LJ53S70SP10*	50	200	250	2000	2400	400	131.5	105.5		
3BPF60LJ53S70SP10*	60	180	230	1500	2800	400	138.5	112.5		
3BPF63LJ53S70SP10*	63	180	200	1500	2500	400	140.8	114.8		

Dimensions

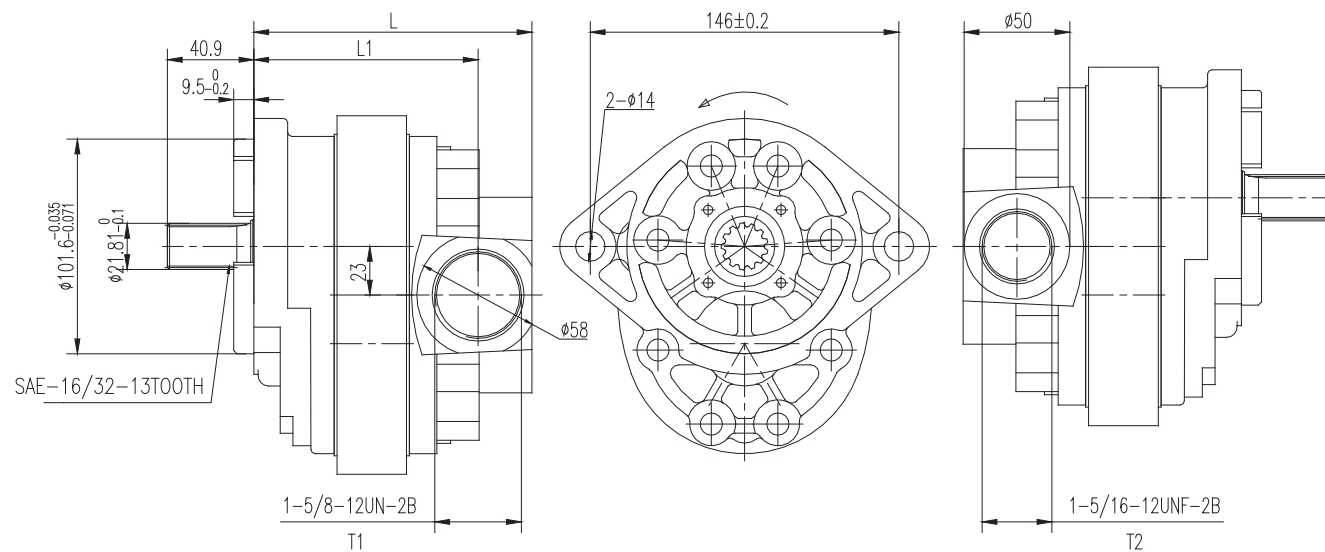

Ordering Code

3	B	P	F	**	LJ53	S70SP10	/L
Group 3	Structure improve number	Gear pump	Pressure F:16~25 Mpa	Displacement 22, 26, 34, 39, 43, 50, 60, 63 ml/r	Inlet/outlet combination	Shaft extension combination	Rotation L= left omit = right

OM08GR08K04S90SP21

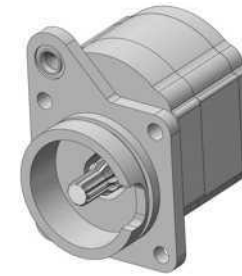

Model	Displacement (ml/r)	Pressure(bar)		Speed(r/min)		
		Rated	Peak	Rated	Max	Min
OM08GR08K04S90SP21	48	100	140	1500	2500	500

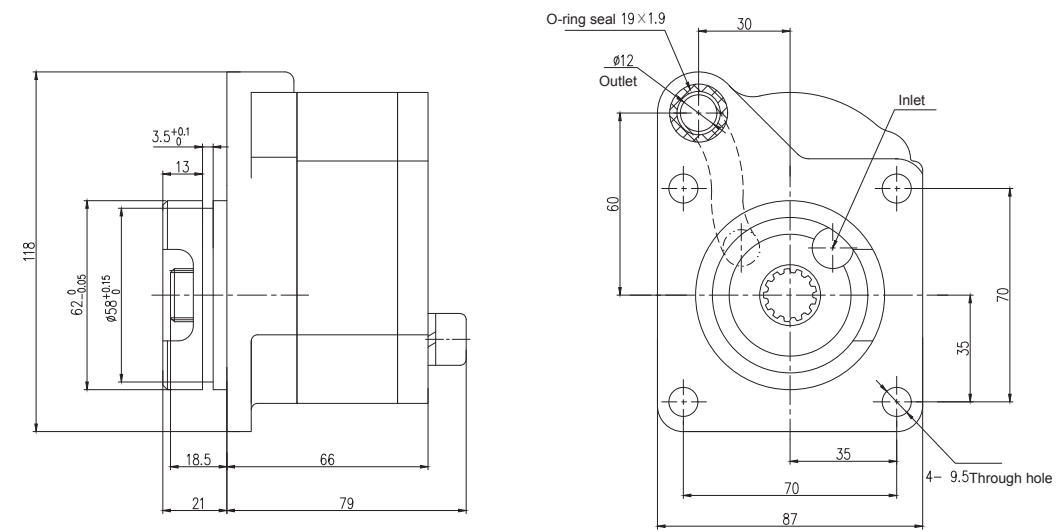

OM08-3GRK03S91SP22**

Model	Displacement (ml/r)	Pressure(bar)		Speed(r/min)		
		Rated	Peak	Rated	Max	Min
OM08-3GR12K03S91SP22	12	100	140	1500	2500	500

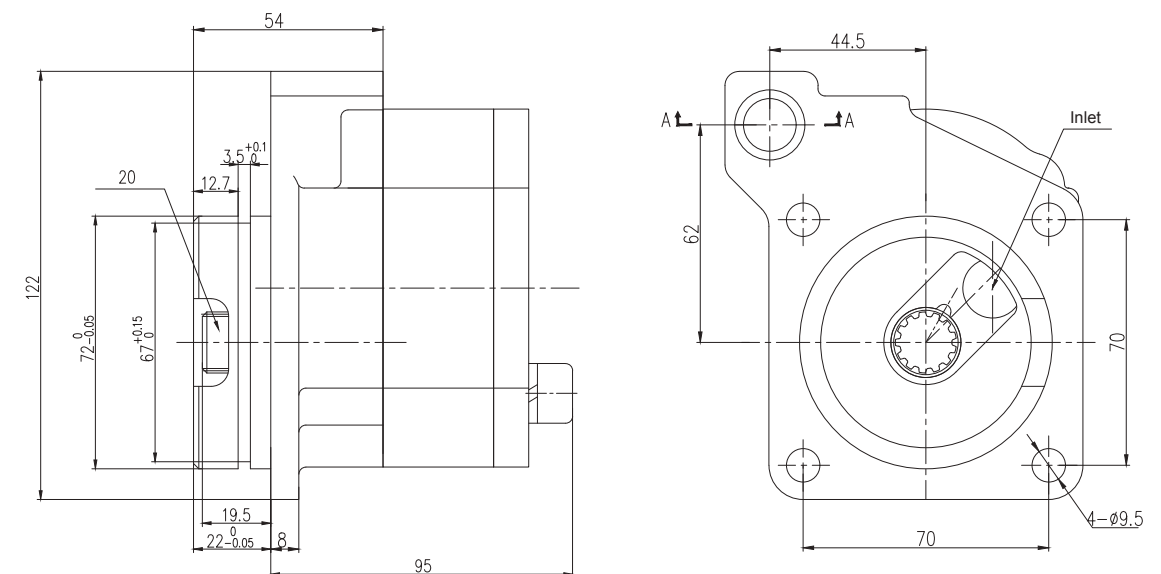



OM401GR18K05S87SP18-X

Model	Displacement (ml/r)	Pressure(bar)		Speed(r/min)			Inlet	Outlet
		Rated	Peak	Rated	Max	Min		
OM401GR18K05S87SP18-X	18	140	160	1500	2500	600	∅ 18	∅ 14

OM601GR18K05S87SP18-X

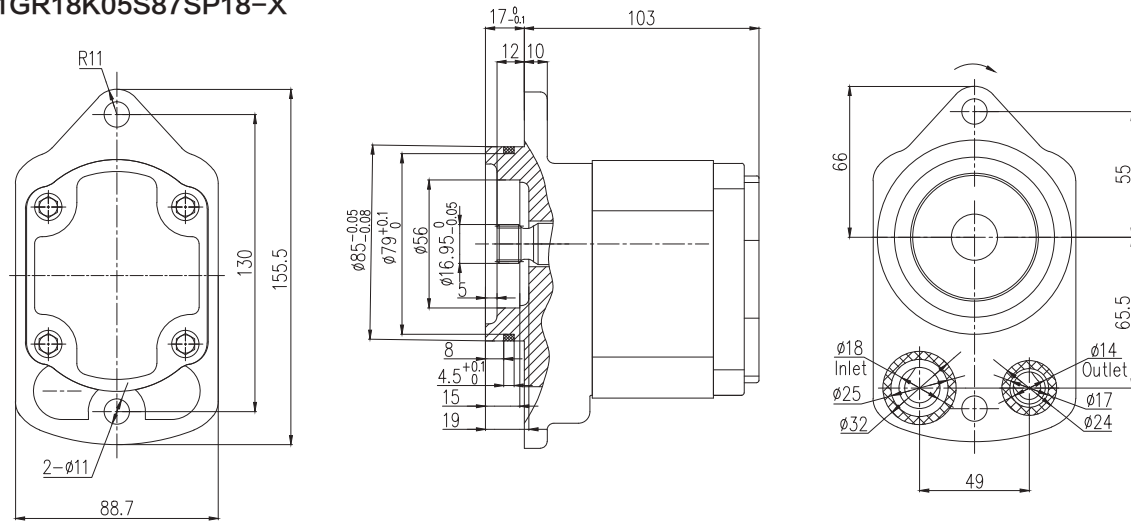

OM601GR18K05S89SP20-X/S88SP19-X

Model	Displacement (ml/r)	Pressure(bar)		Speed(r/min)			Inlet	Outlet
		Rated	Peak	Rated	Max	Min		
OM601GR18K05S89SP20-X	18	140	160	1500	2500	600	∅ 18	∅ 14
OM601GR18K05S88SP19-X	18	140	160	1500	2500	600	∅ 18	∅ 14

OM601GR18K05S89SP20-X

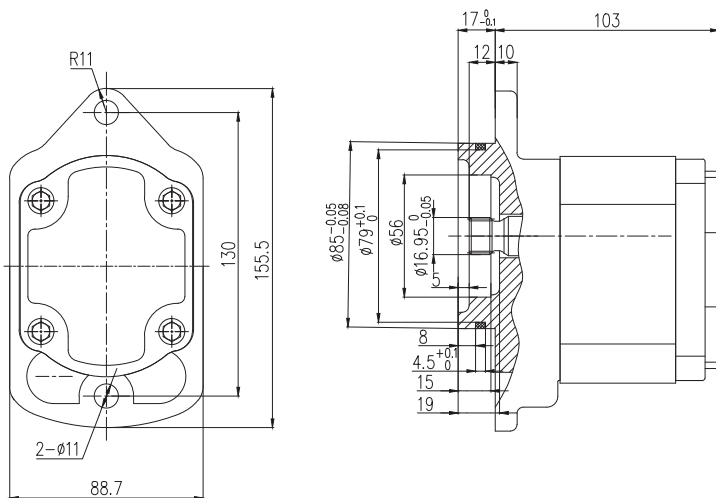

OM601GR18K05S88SP19-X

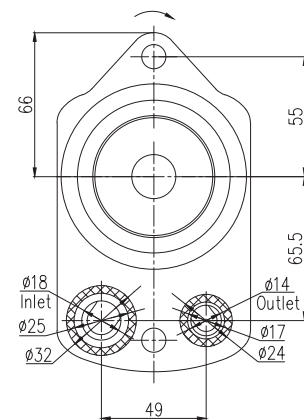

OM701GR17K03S86SP17-X

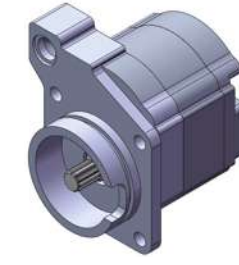

Model	Displacement (ml/r)	Pressure(bar)		Speed(r/min)		
		Rated	Peak	Rated	Max	Min
OM701GR17K03S86SP17-X	17	140	160	1500	2500	600

OM701GR17K03S86SP17-X

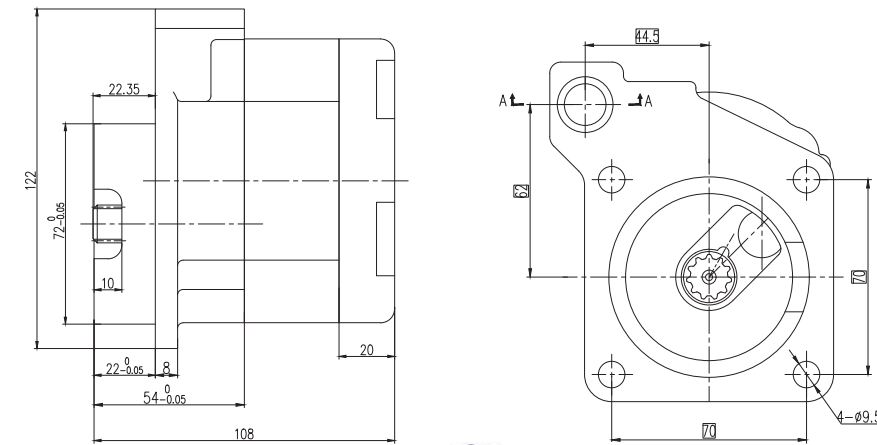

OM702GR10K04S84D14



Model	Displacement (ml/r)	Pressure(bar)		Speed(r/min)			Inlet	Outlet
		Rated	Peak	Rated	Max	Min		
OM702GR10K04S84D14	10	100	160	1500	2500	600	∅ 14	∅ 8

OM702GR10K04S84D14

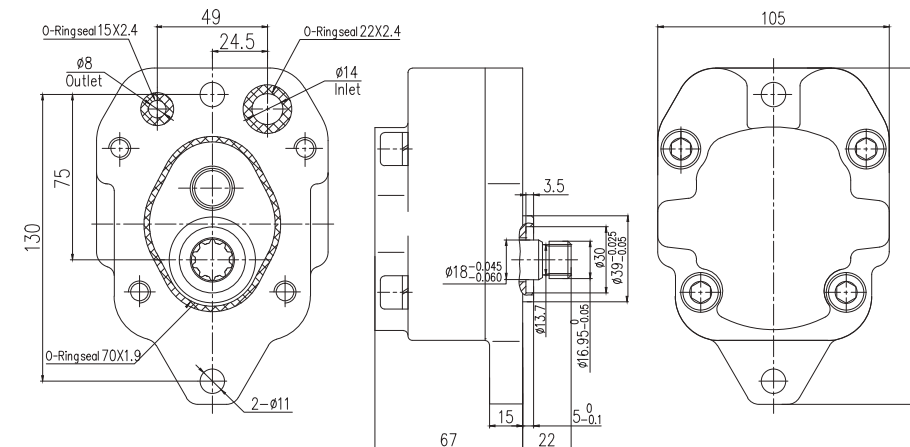

OM14GR**LJ41F107SP16

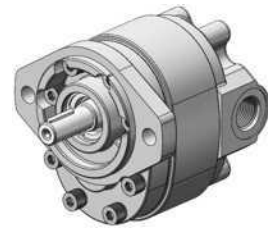

Model	Displacement (ml/r)	Pressure(bar)		Speed(r/min)			L (mm)	L1 (mm)	Inlet	Outlet
		Rated	Peak	Rated	Max	Min				
OM14GR17LJ41F107SP16	17	160	180	1500	2500	500	104.5	84	1-5/16- 12UN-2B	7/8- 14UNF-2B
OM14GR20LJ41F107SP16	20	160	180	1500	2500	500	108	87.5		
OM14GR23LJ41F107SP16	23	160	180	1500	2500	500	112	91.5		
OM14GR24LJ41F107SP16	24	160	180	1500	2500	500	113	92.5		
OM14GR25LJ41F107SP16	25	160	180	1500	2500	500	114	93.5		
OM14GR28LJ41F107SP16	28	160	180	1500	2500	500	117.5	97		
OM14GR29LJ41F107SP16	29	160	180	1500	2500	500	119	98.5		
OM14GR30LJ41F107SP16	30	160	180	1500	2500	500	120	99.5		

Dimensions

OM14GR**LJ41F107SP16

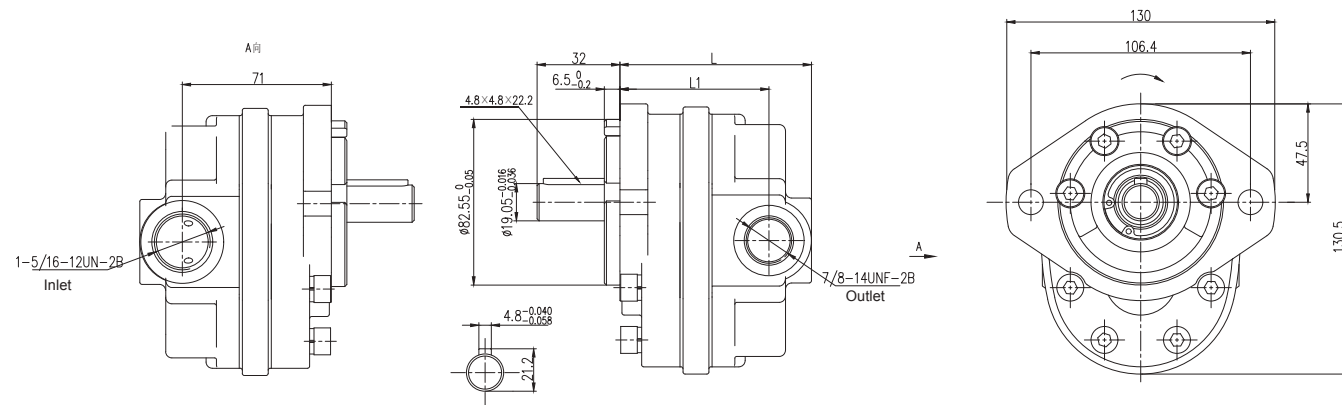

2CP 18 Constant Flow Gear Pumps



Model	Displacement(ml/r)	Constant flow(L/min)	Max Pressure(bar)	Speed(r/min)
2[C]P18 16/14L17F106D18SS	18	16	10	500-3200

Involute Spline parameter

m	Z	Pressure angle	Precision
1	16	300	5h

Dimensions

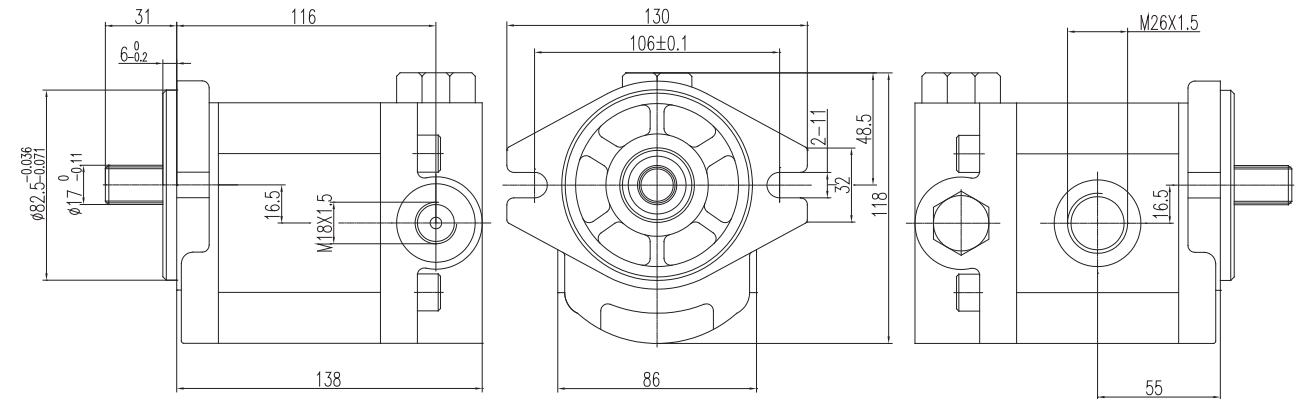

Ordering Code

2	[C]P	**	16/14	L17	F106D18	/L	SS
Group 2	Constant flow Gear pump	Displacement 18 ml/r	Control flow: 16L/min safety valve pressure: 14MPa	Inlet/outlet combination	Shaft extension combination	Rotation L= left omit = right	inlet/out position combination BB, BS, SB, SS

2CP 18 Constant Flow Gear Pumps

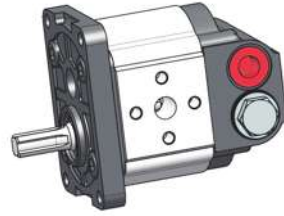

Model	Displacement (ml/r)	Constant flow (L/min)	Max Pressure (bar)	Speed (r/min)	L	L1	L2
2[C]P6 6/12.5LF01R17S7LSS	6	6	125	500-3200	47	98	120
2[C]P10 6/12.5LF01R17S7LSS	10	6	125	500-3200	49.75	103.5	125.5
2[C]P14 10/12.5LF01R17S7LSS	14	10	125	500-3200	52.85	109.5	131.7

Dimensions

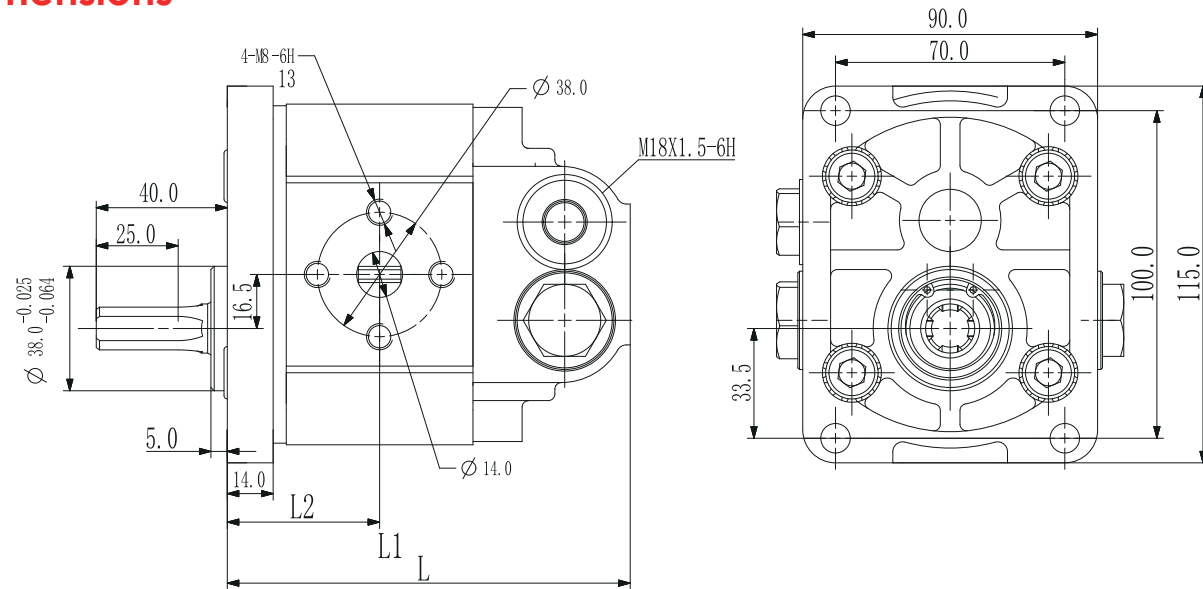

Ordering Code

2	[C]P	**	*/12.5	LF01	R17S7	/L	SS
Group 2	Constant flow Gear pump	Displacement 6, 10, 14 ml/r	Control flow: 6, 10L/min safety valve pressure: 12.5 MPa	Inlet/outlet combination	Shaft extension combination	Rotation L= left omit = right	inlet/out position combination BB, BS, SB, SS

2CB-E**/** HI/LO Gear Pumps

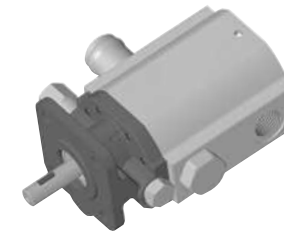

Model	Flow (gpm) 3600 r/min	Pressure (PSI)		Displacement (Cu.in/r)		Speed (rpm)	D	
		LO	HI	LO	HI		Inlet	Outlet
2CB-E6.3/2.1	8	400/900	3000	0.385	0.13	3600	1 IN PIPE	1/2 NPT
2CB-E6.3/3.0	8.5	400/900	3000	0.385	0.183			
2CB-E6.3/3.6	9	400/900	3000	0.385	0.220			
2CB-E8.8/2.1	10	400/900	3000	0.537	0.13			
2CB-E8.8/3.0	10.5	400/900	3000	0.537	0.183			
2CB-E8.8/3.6	11	400/900	3000	0.537	0.220			
2CB-E8.8/4.2	11.5	400/900	3000	0.537	0.256			
2CB-E10.9/2.1	12	400/900	3000	0.665	0.13			
2CB-E10.9/3.0	12.5	400/900	3000	0.665	0.183			
2CB-E10.9/3.6	13	400/900	3000	0.665	0.220			
2CB-E10.9/4.2	13.5	400/900	3000	0.665	0.256			
2CB-E13.0/4.2	16	400/900	3000	0.793	0.265			

Dimensions

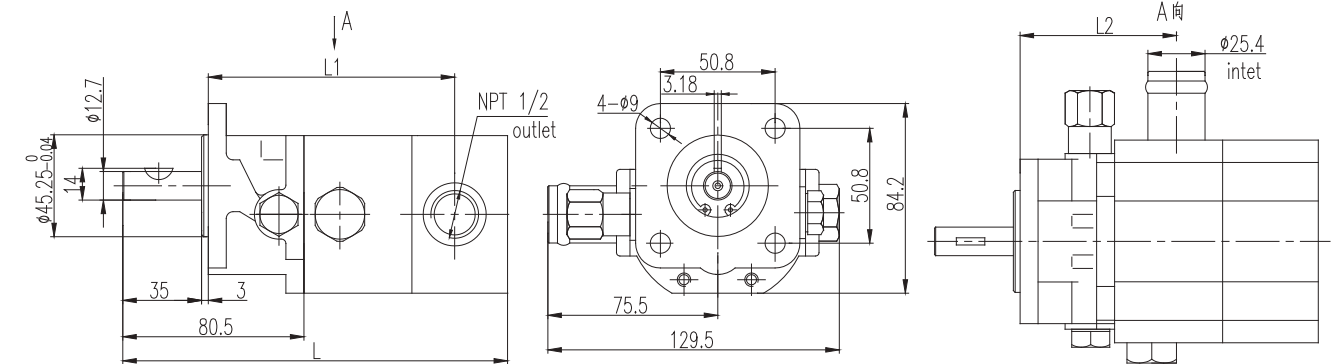

Model	Dimension/In			Model	Dimension/In			Model	Dimension/In		
	L	L1	L2		L	L1	L2		L	L1	L2
2CB-E6.3/2.1	6.07	3.74	2.41	2CB-E8.8/3.0	6.54	4.08	2.74	2CB-E10.9/3.0	6.90	4.53	3.04
2CB-E6.3/3.0	6.21	3.90	2.41	2CB-E8.8/3.6	6.61	4.24	2.74	2CB-E10.9/3.6	7.00	4.53	3.04
2CB-E6.3/3.6	6.28	3.90	2.74	2CB-E8.8/4.2	6.70	4.24	2.74	2CB-E10.9/4.2	7.09	4.53	3.04
2CB-E8.8/2.1	6.41	4.08	2.74	2CB-E10.9/2.1	6.70	4.37	3.04	2CB-E13.0/4.2	6.70	4.37	3.04

2CB-E**/** HI/LO Gear Pumps



Model	Flow(gpm) 3600 r/min	Pressure (PSI)		Displacement (Cu.in/r)		Speed (rpm)	D	
		LO	HI	LO	HI		Inlet	Outlet
2CB-E15.2/7.6	22	400/900	3000	0.93	0.465	3600	NPTF 1	NPTF3/4
2CB-E22.9/7.6	28	400/900	3000	1.395	0.465		G1	G3/4

Dimensions

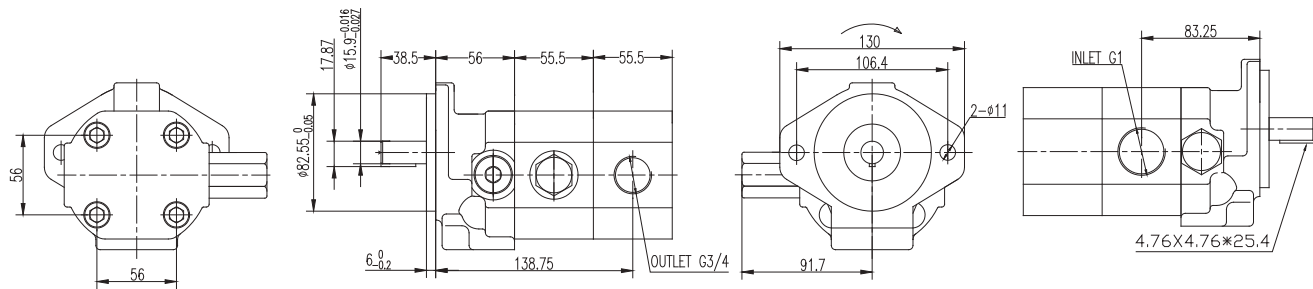

Performance curves

2CB-E15.2/7.6

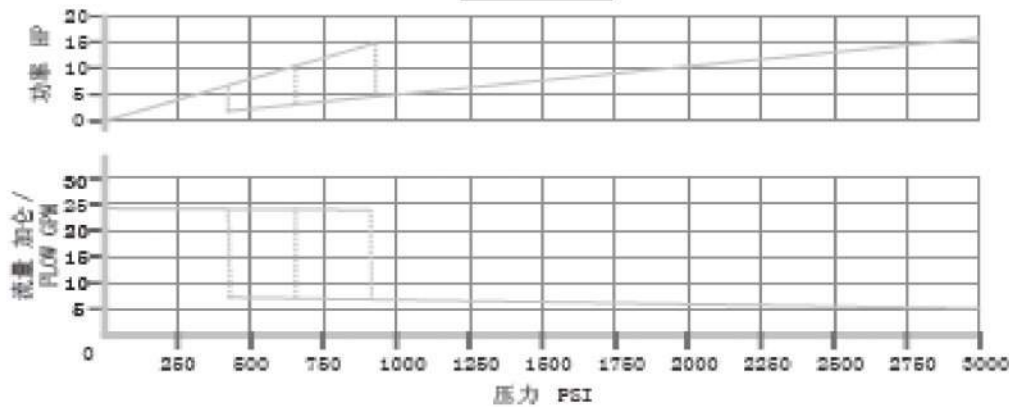

2CB-E22.9/7.6

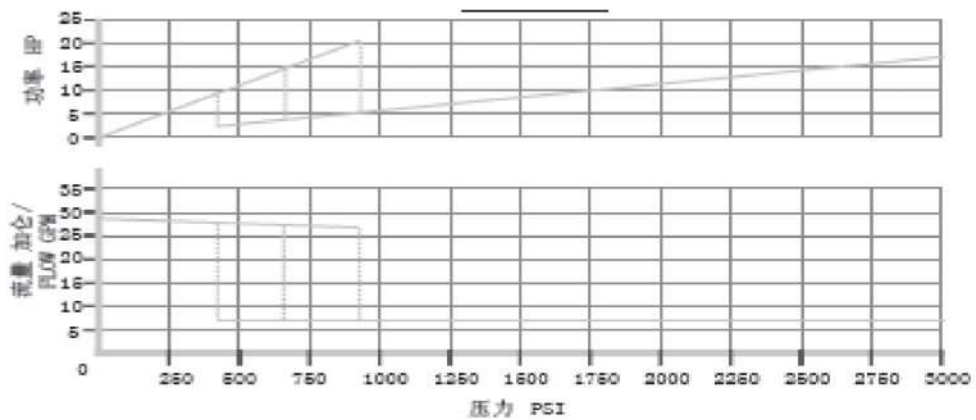

PTO Gear Pumps



PTO pump can be used in the hydraulic systems of agriculture tractors

Model	Displacement (cc/r)	Pressure Max	Speed Rated	L (mm)	L1 (mm)	L2 (mm)	L3 (mm)	L4 (mm)	L5 (mm)
CB-P160LJ53S33BB	160	160 bar (2250 psi)	1000RPM	60.2	53	86	86	161	61
CB-P125LJ53S33BB	125			50.8	50.8	81	81	151	52
CB-P90LJ53S33BB	90			41.5	44	76	76	142	47.5
CB-P56LJ53S33BB	56			32	39	71	71	133	42.5
CB-P160LJ42H21SS	160			60.2	53	86	86	161	61
CB-P125LJ42H21SS	125		540RPM	50.8	48	81	81	151	52
CB-P90LJ42H21SS	90			41.5	44	76	76	142	47.5
CB-P56LJ42H21SS	56			32	39	71	71	133	42.5

Dimensions

CB-P***LJ53S33BB

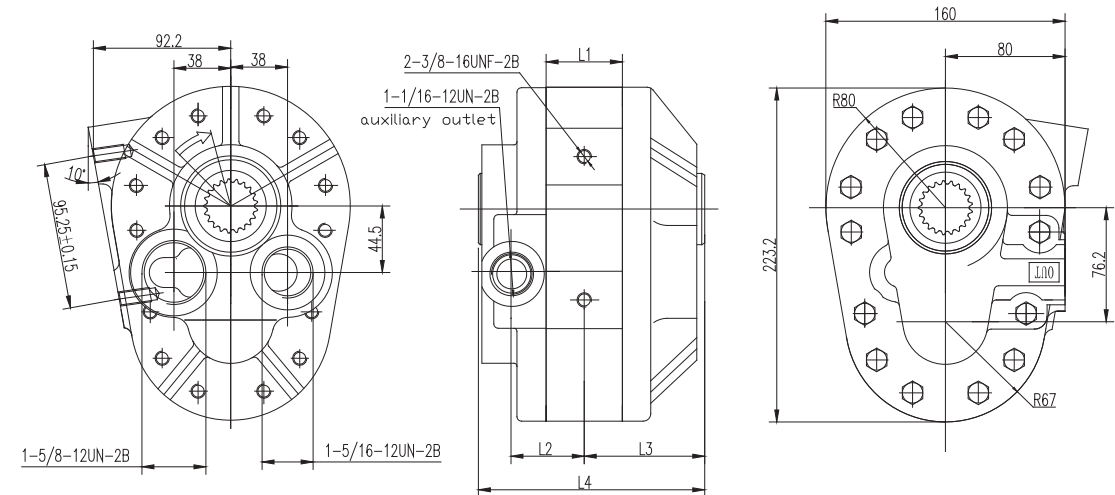

CB-P***LJ42H21SS

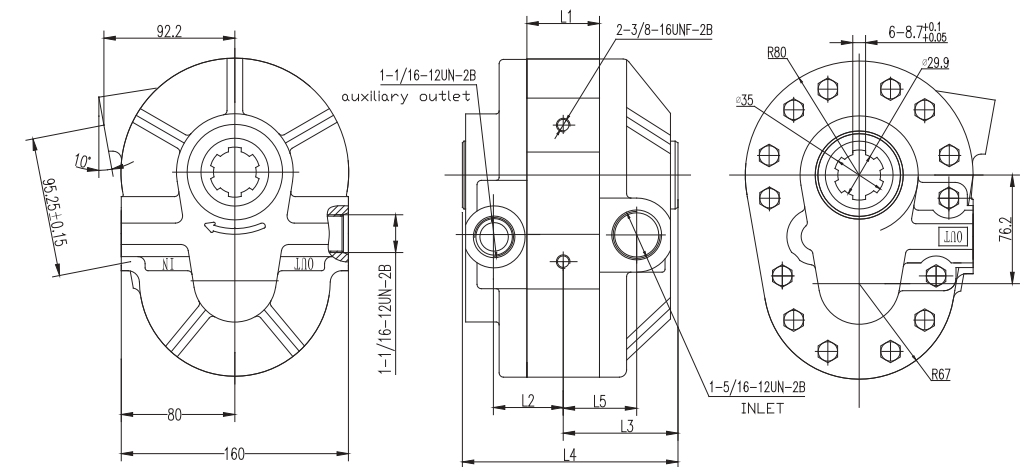

Aluminum Multiple Pumps

1	D	P	F	**/**	DL01	T3	S7	L-	SS	F-	O	-V
a	b	c	d	e	f	g	h	i	j	k	l	m

- Ⓐ 1=Group
1, 1.5, 2, 3 Group
- Ⓑ Function
D=Double Pump
T=Triple Pump
F=Four Stage Pump
- Ⓒ P=Gear Pump
- Ⓓ Pressure Rate
E=160bar
F=200bar
G=250bar
- Ⓔ Displacement(ml/r)
first stage/second stage/third stage/forth stage
- Ⓕ DL01=Port
- Ⓖ T3=Shaft
- Ⓗ S7=Front covers
- Ⓘ Rotation
R=CW
L=CCW
B=Bi-directional
- Ⓚ Ports Combination
SS=side inlet and side outlet
SB=side inlet and back outlet
BS=back inlet and Side outlet
BB=back inlet and back outlet
- Ⓛ Seal
F=FKM Seal
Omit=NBR Seal
- Ⓜ Outboard Bearing
O=Outboard Bearing
Omit=Without Outboard Bearing
- Ⓝ Options
V(Relief valve) D(Check valve)

Ⓕ Line ports	Ⓖ Drive shafts	Ⓗ Front covers
DF02 Ø40,4-M8,Ø20 Ø30,4-M6,Ø13 DF05 Ø40,4-M8,Ø20 Ø30,4-M6,Ø13 Ø40,4-M6,Ø20 Ø35,4-M6,Ø15 Ø40,4-M6,Ø20 Ø35,4-M6,Ø15 DF08 Ø56,4-M10,Ø27 Ø56,4-M10,Ø27 Ø38,4-M8,Ø18 Ø38,4-M8,Ø15	T10 Tapered key shaft 1:5 T3 Tapered key shaft 1:8 F32 Straight keyed shaft SAE A Ø15.88mm S15 Splined shaft 9teeth 15.45mm	S7 4-hole mounting 71.5x96.2mm D9 2-groove mounting Ø106mm S12 4-hole mounting 98.5x128mm D12 2-hole mounting Ø146mm

1DPF**/**DL**F16D2*



Displacement (ml/r)	1.3	2.0	2.7	3.4	4.1	5.1	6.1
L3/L4	44	46	48	50	52	55	58
L	82	84	86	88	90	93	96
L1	42	43	44	45	46	47.5	49

Dimensions

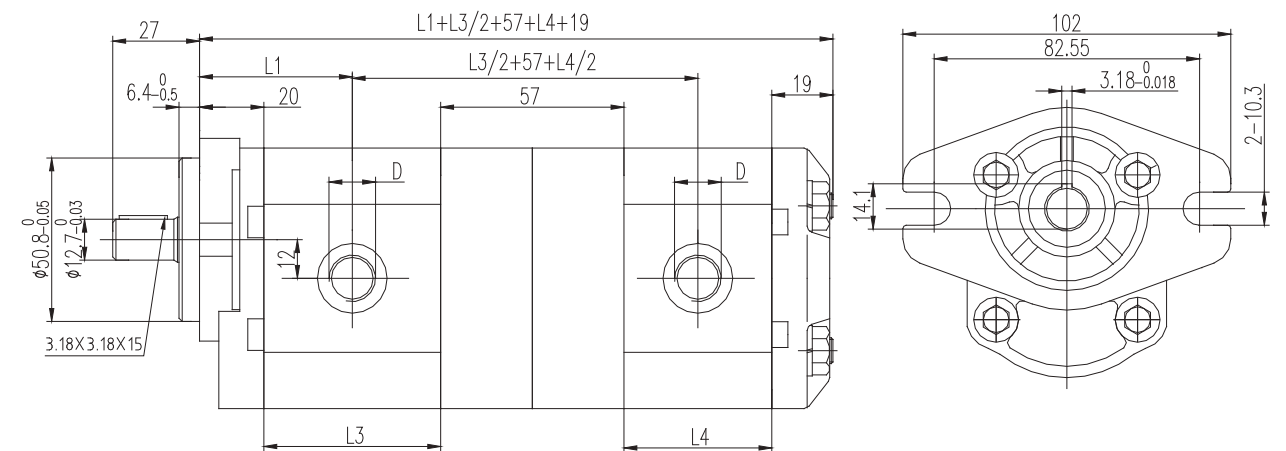

1DPF**/**DL**T3S5*

Displacement (ml/r)	1.1	1.3	1.6	2.1	3.2	3.7	4.2	4.8	5.8	8.0
L3/L4	36	37	38	40	44	46	48	50	54	62
L	75	76	78	79	83	85	87	89	93	101
L1	33	34	35	36	38	39	40	41	43	47

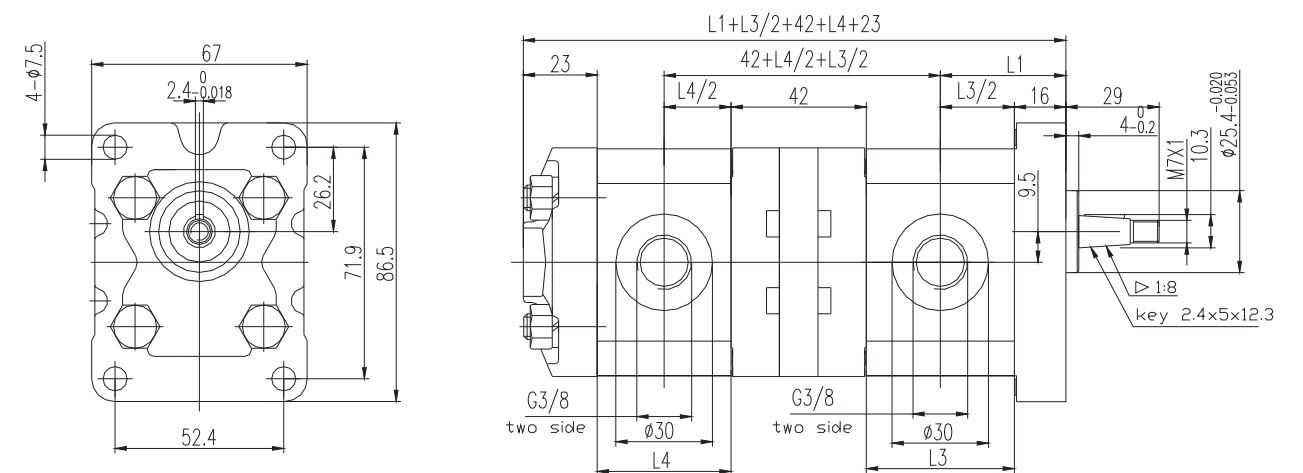

1.5BDPF*DL**S94SP11***



Model	Displacement(ml/r)		Pressure(bar)				Speed(r/min)			L (mm)	L1 (mm)
	Front Pump	Rear Pump	Rated	Peak	Rated	Peak	Rated	Max	Min		
1.5BDPF3/3DFL17S94SP11L	3	3	4	10	140	200	1500	3200	800	106.2	56
1.5BDPF4/4DL20S94SP11L	4	4	4	10	140	200	1500	3200	800	106.2	56

Dimensions

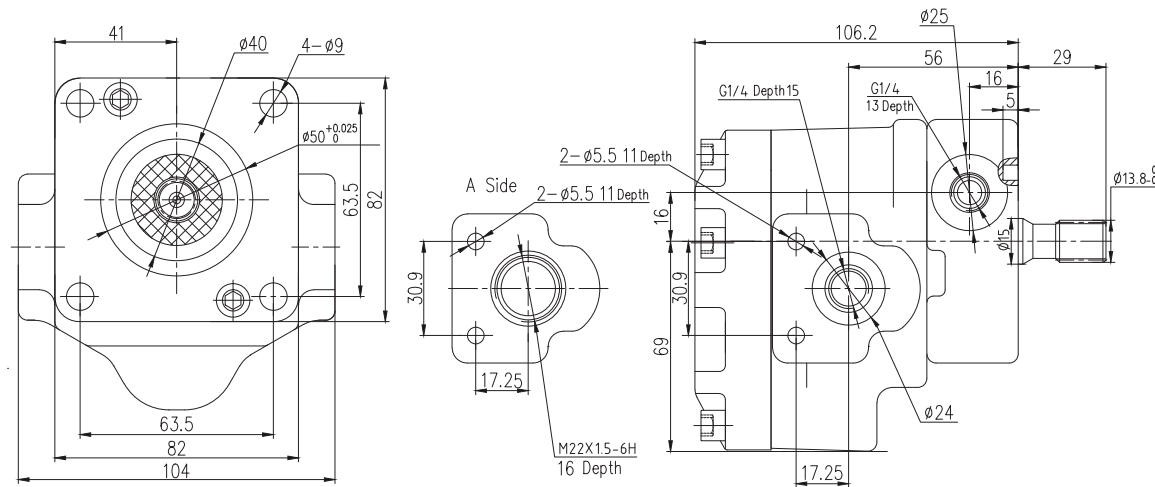

1.5DPF/**DF50F13S3***

Displacement (ml/r)	2	3	4	5	6	7	8	9	10	11	12
L1	42	44	46	48	50	52	54	56	58	60	62

Dimensions

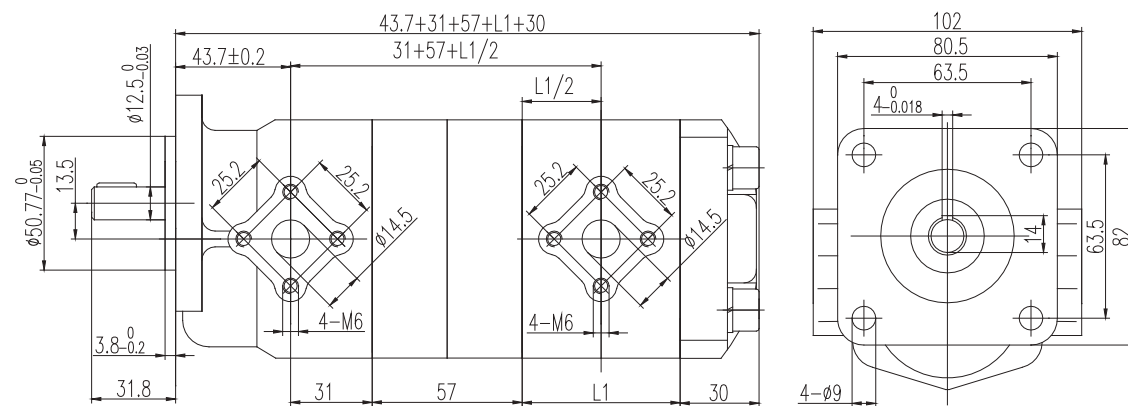

2/1DPF/**DF**T24S7***

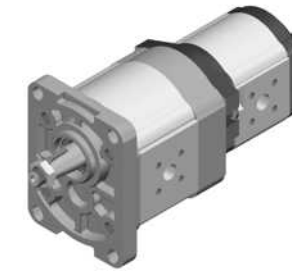

L(mm)	42.3	44	45.5	47	48.8	50	52	54	55	58	59	61	63
Displacement(ml/r)	4	6	8	10	12	14	16	18	20	23	25	28	30
L3(mm)	50.5	54	57	60	63	66	69	72.5	76	80.5	83	88	91
Displacement(ml/r)	1.3	2.0	2.7	3.4	4.1	5.1	6.1	/	/	/	/	/	/
L4(mm)	44	46	48	50	52	55	58	/	/	/	/	/	/

Dimensions

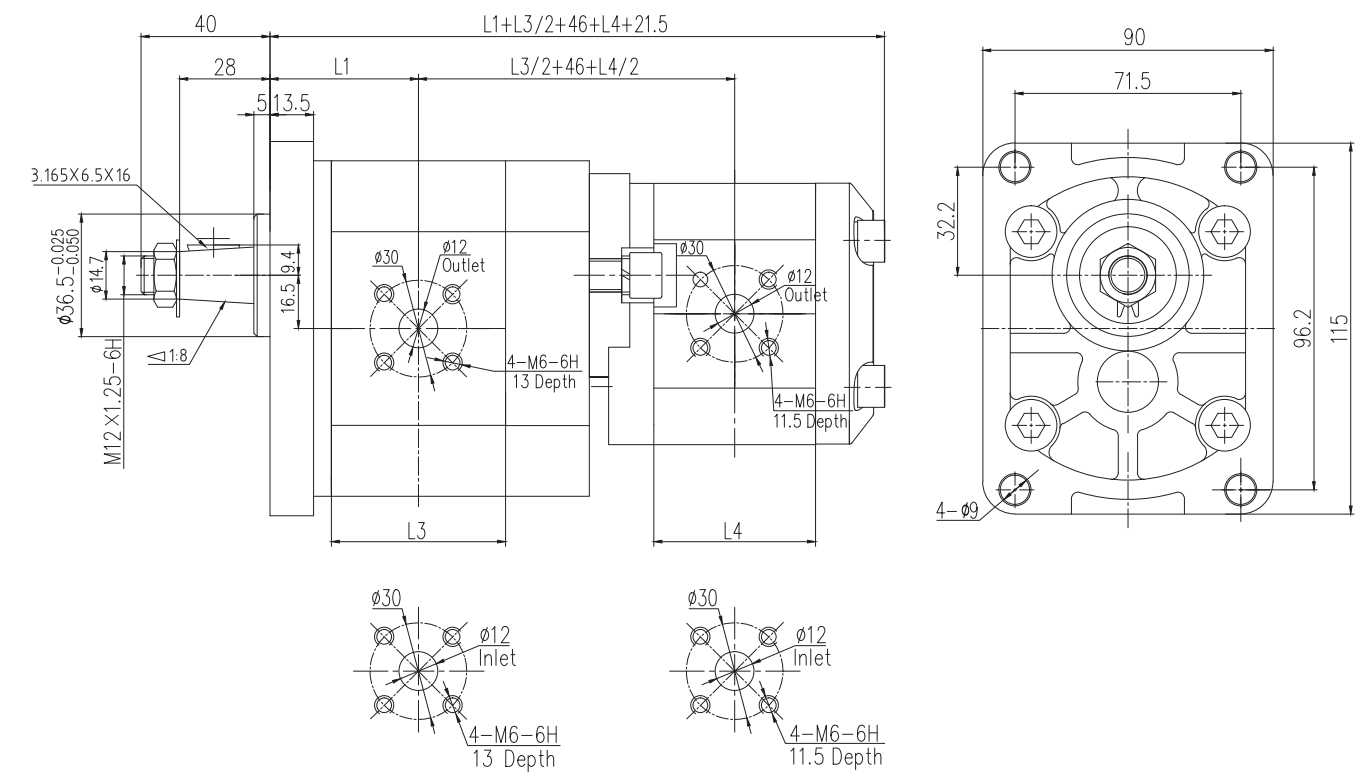

2ADPF **/**DL**F32D9*



Displacement (ml/r)	4	6	8	10	12	14	16	18	20	23	28	30
L3/L4	50.5	54	57	60	63	66	69	72.5	76	80.5	88	91
L	96	98	102	104	108	110	114	117	120	123	133	136
L1	43.3	45	46.5	48	50	51	53	55	56	58	63	64

Dimensions

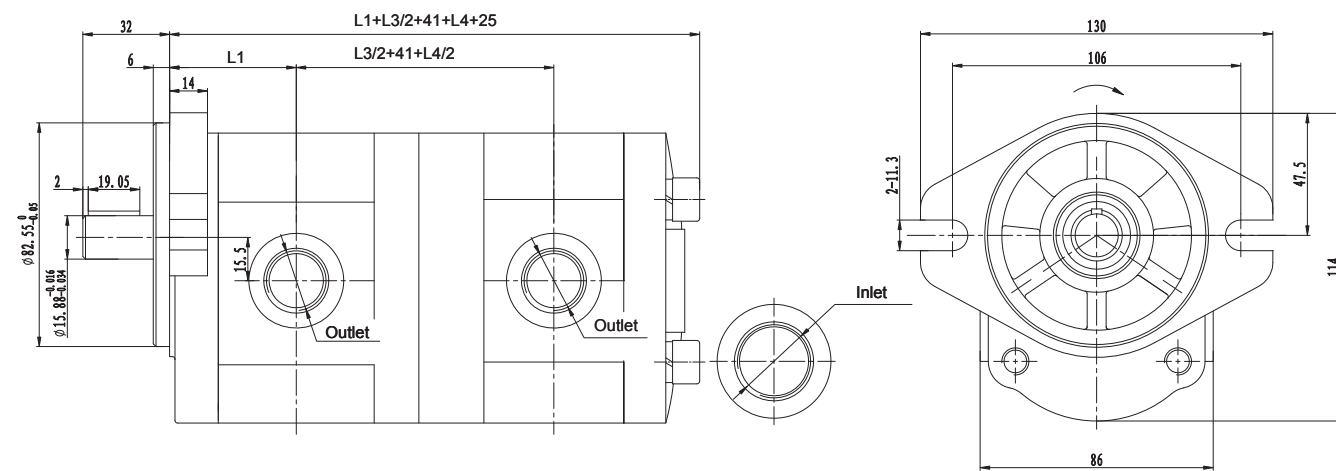

2ADPF **/**DF**T24S7*

Displacement (ml/r)	4	6	8	10	12	14	16	18	20	23	28	30
L3/L4	50.5	54	57	60	63	66	69	72.5	76	80.5	88	91
L	96	98	102	104	108	110	114	117	120	123	133	136
L1	43.3	45	46.5	48	50	51	53	55	56	58	63	64

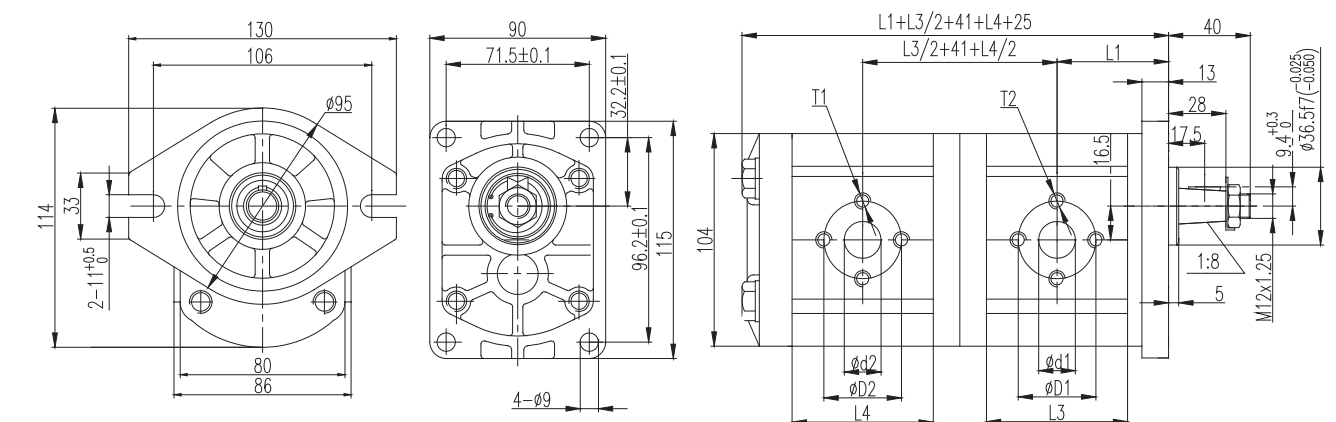

2ADPF **/**DL**S18D9*



Displacement (ml/r)	4	6	8	10	12	14	16	18	20	23	28	30
L3/L4	50.5	54	57	60	63	66	69	72.5	76	80.5	88	91
L	96	98	102	104	108	110	114	117	120	123	133	136
L1	43.3	45	46.5	48	50	51	53	55	56	58	63	64

Dimensions

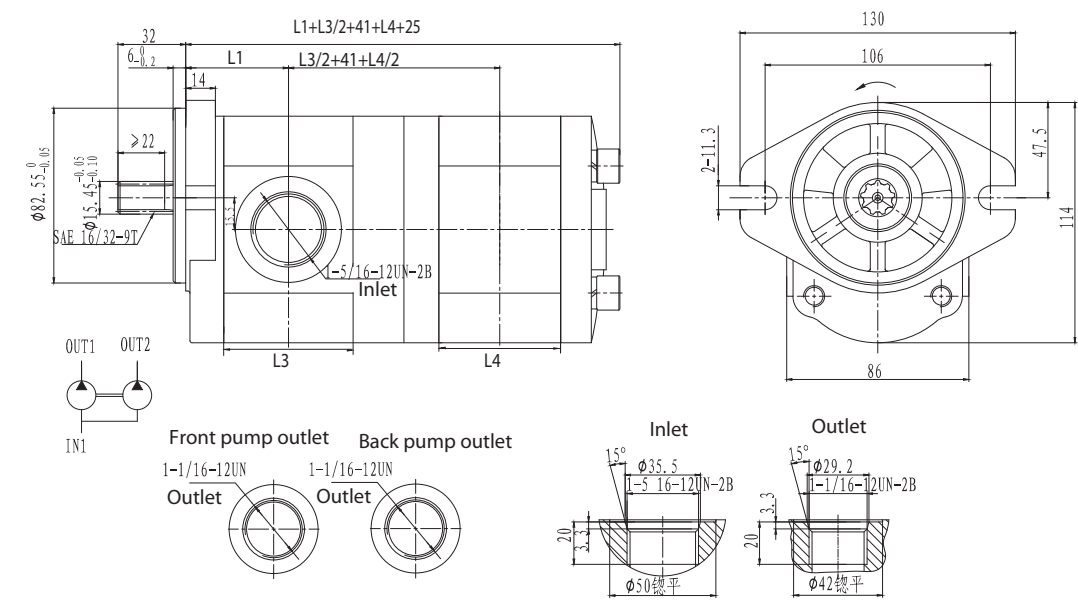

2ADPF **/**DF**T10S8*

Displacement (ml/r)	4	6	8	10	12	14	16	18	20	23	28	30
L3/L4	50.5	54	57	60	63	66	69	72.5	76	80.5	88	91
L	96	98	102	104	108	110	114	117	120	123	133	136
L1	43.3	45	46.5	48	50	51	53	55	56	58	63	64

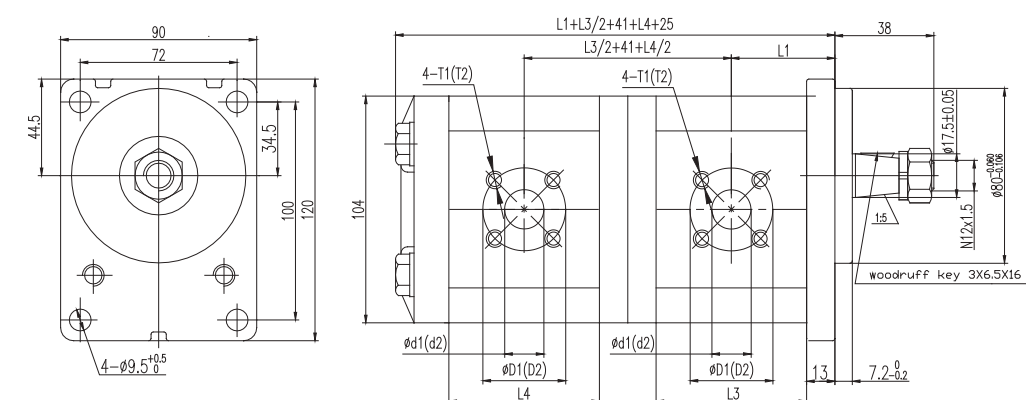

2ATPF/**/**TF02*****



Model	Displacement (ml/r)	Pressure(bar)		Speed(r/min)			L (mm)	L1 (mm)	Inlet			Outlet		
		Rated	Peak	Rated	Max	Min			øD1	ød1	T1	øD2	ød2	T2
2APF04F60*	4	200	250	2000	3500	500	87.9	42.2	40	15	M6	30	15	M6
2APF06F60*	6	200	250	2000	3500	500	91.1	43.8						
2APF08F52*	8	200	250	2000	3500	500	94.3	45.4						
2APF10F52*	10	200	250	2000	3500	500	97.5	47.0						
2APF12F52*	12	200	250	2000	3500	500	110.7	48.6						
2APF14F52*	14	200	250	2000	3500	500	114.0	50.2						
2APF16F52*	16	200	250	2000	3500	500	109.5	51.2						
2APF18F52*	18	200	250	2000	3500	500	113.0	52.8						
2APF20F52*	20	200	250	2000	3500	500	116.5	55.3						
2APF23F52*	23	200	250	2000	3000	500	121.5	56.9						
2APF25F52*	25	200	250	2000	3000	500	124.7	58.5						

Dimensions

2TPF**/**/**TF02T2008* Triple Pump

Option:2TPF**/**/**TF02F63D9*

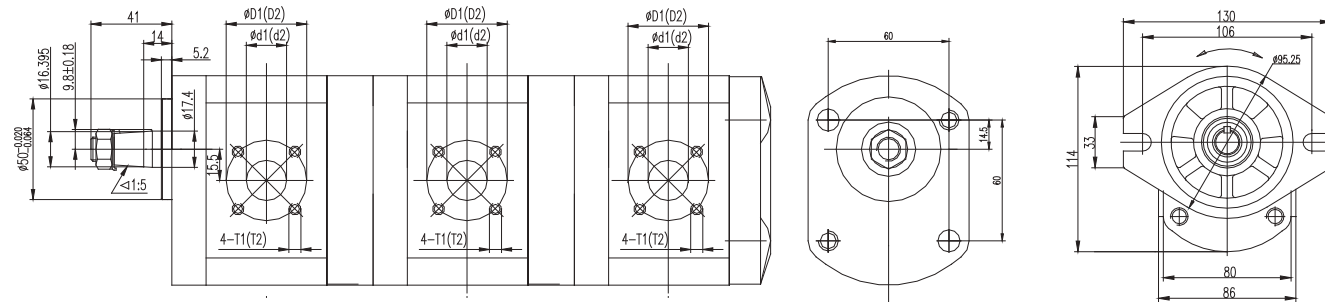

Ordering code:2APF**F52T2008*-A Ordering code:2APF**F52*-M

Ordering code:2APF**F52*-B

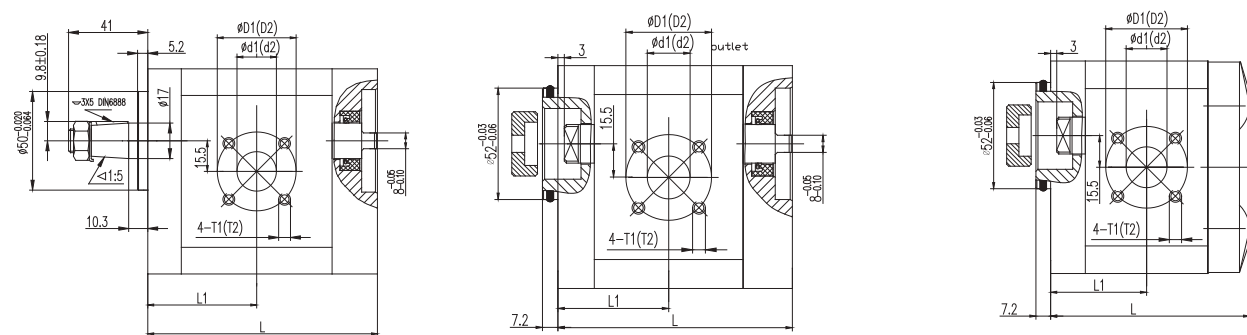

2ATPF10/5/5TLJ04S46D9



Model	Displacement (ml/r)	Pressure(bar)		Speed(r/min)			Inlet	Outlet
		Rated	Peak	Rated	Max	Min		
2ATPF10/5/5TLJ04S46D9	10/5/5	200	250	2500	3000	500	1-5/16-12UN-2B	3/4-16UNF-2B

Dimensions

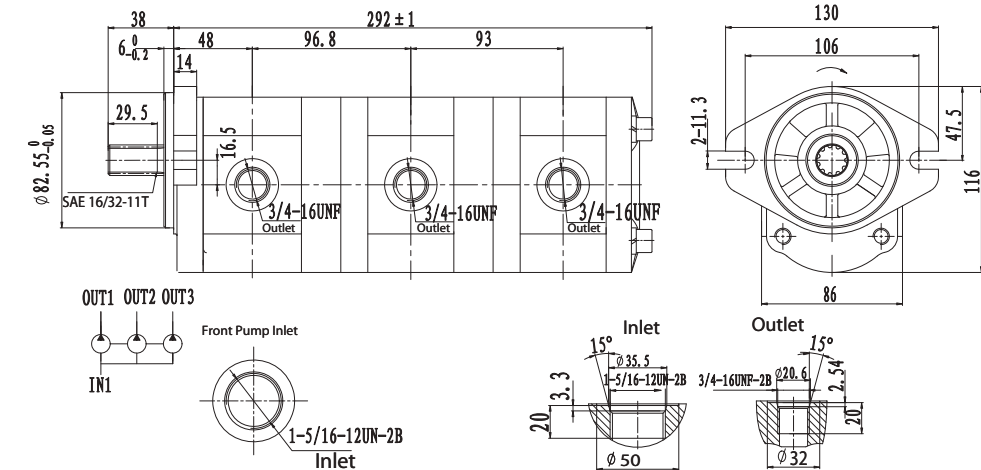

2ATPF14/14/8TL28S35D9-C



Model	Displacement (ml/r)	Pressure/(bar)		Speed(r/min)			Inlet	Outlet
		Rated	Peak	Rated	Max	Min		
2ATPF14/14/8TL28S35D9-C	14/14/8	160	200	2000	3000	500	NPT3/4	NPT1/2

Dimensions

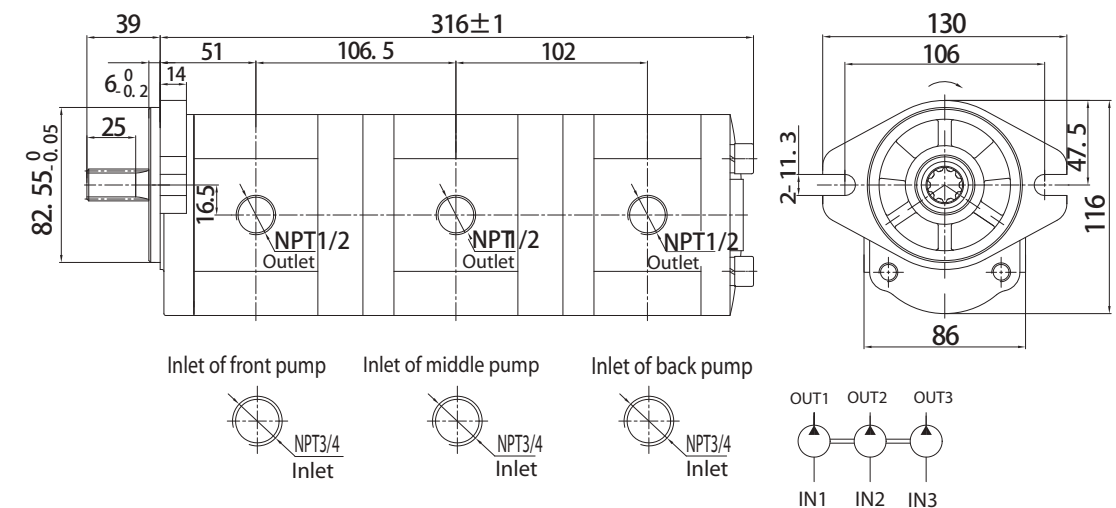

2AAPP4/4/4/4FLJF63D9**



Model	Displacement (ml/r)	Pressure(bar)		Speed(r/min)		
		Rated	Peak	Rated	Max	Min
2AAPP4/4/4/4FLJ**F63D9	4/4/4/4	200	250	2000	3000	500

Dimensions

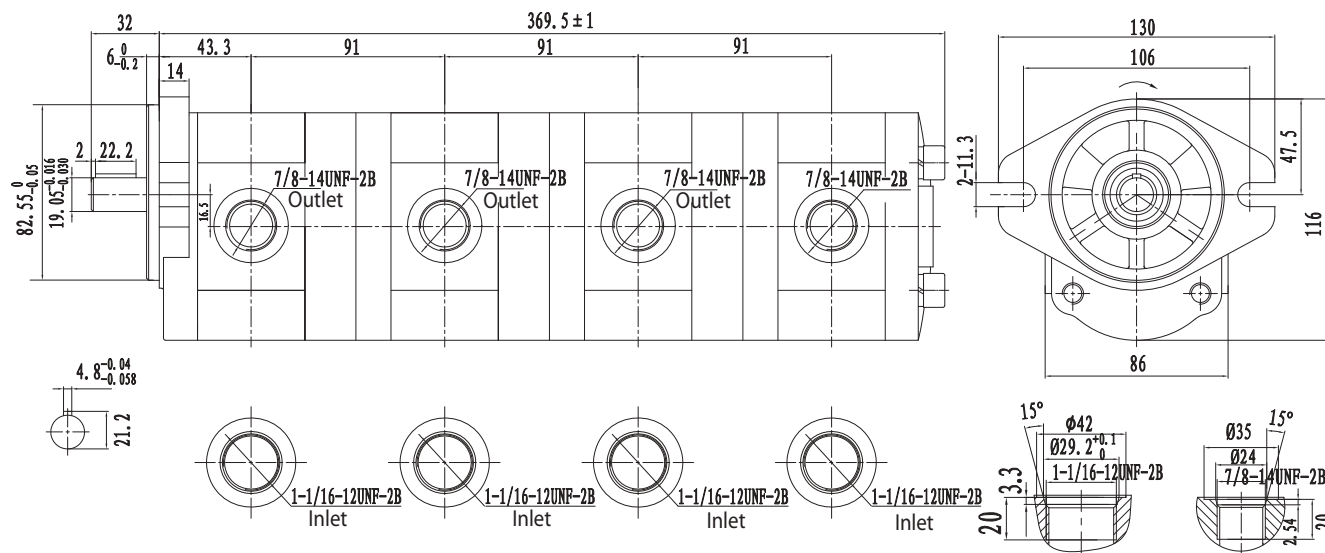

3/2ADPF25/08DF129T40S14*



Model	Displacement (ml/r)	Pressure/(bar)		Speed(r/min)		
		Rated	Peak	Rated	Max	Min
3/2ADPF25/08DF129T40S14*	25/08	200	250	2000	3000	500

Dimensions

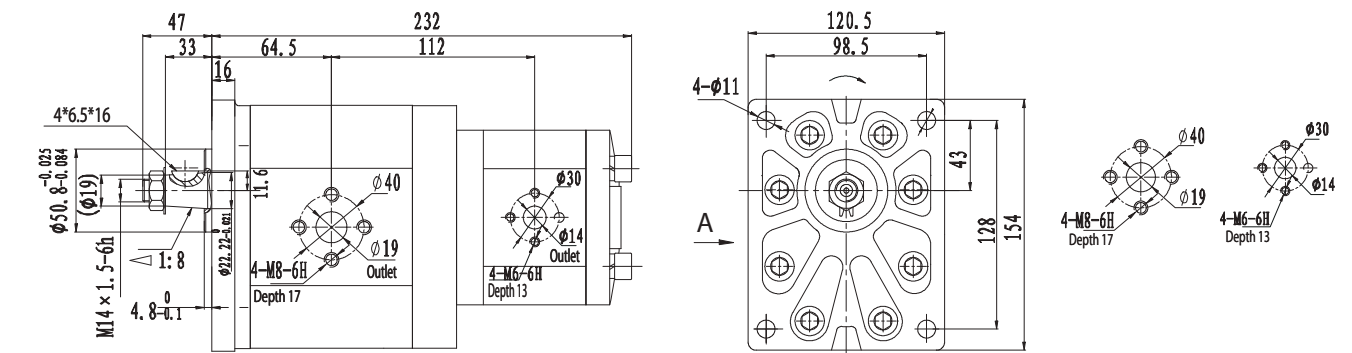

3/2ADPF32/23DF128S70D12*



Model	Displacement (ml/r)	Pressure(bar)		Speed(r/min)		
		Rated	Peak	Rated	Max	Min
3/2ADPF32/23DF128S70D12*	32/23	200	250	2000	3000	500

Dimensions

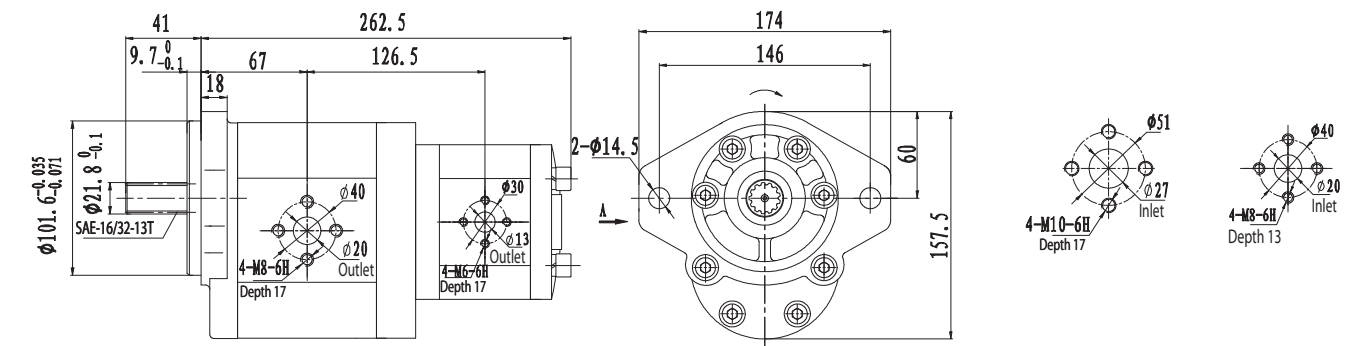

3ADPF/**DL**T40S14***



Displacement(ml/r)	22	26	34	39	43	51	60	70
L3/L4	80	83	88.5	92.5	95	101	107.5	114.5
L	128.5	131.5	137	141	143.5	149.5	156	163
L1	65.5	67	69.8	71.8	73	76	79.3	82.8

Dimensions

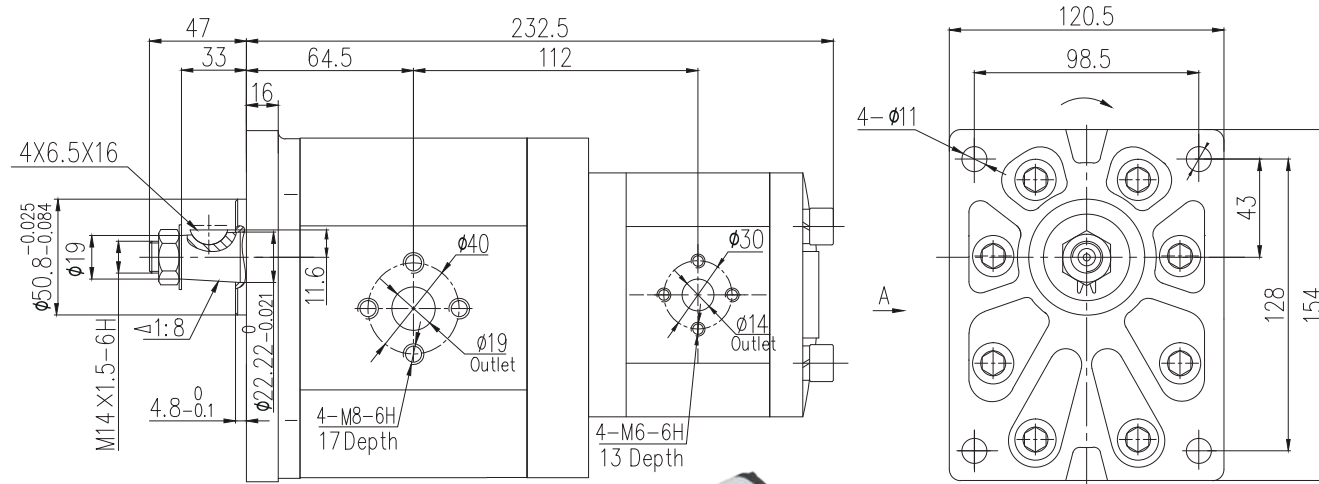

3ADPF/**DL**S70D12*****

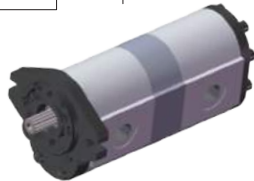

Displacement(ml/r)	22	26	34	39	43	51	60	70
L3/L4	80	83	88.5	92.5	95	101	107.5	114.5
L	128.5	131.5	137	141	143.5	149.5	156	163
L1	65.5	67	69.8	71.8	73	76	79.3	82.8

Dimensions

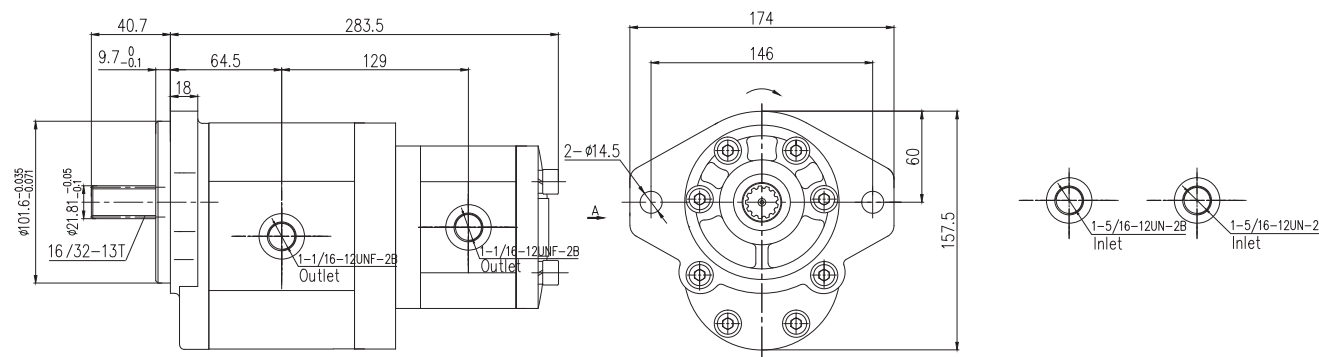

3ATPFTL**S70D12***



Model	Displacement (ml/r)	Pressure/(bar)		Speed(r/min)			L (mm)	L1 (mm)	L2 (mm)	B2 (mm)	ØD1 (mm)	T1 (mm)	L3 (mm)	B3 (mm)	ØD2 (mm)	T2 (mm)
		Rated	Peak	Rated	Max	Min										
3ATPF**TL**S70D12*	22	200	250	2000	3000	400	130.3	65.3	52.4	26.2	27	3/8 16UNC -2B	26.2	47.6	19	3/8 16UNC -2B
3ATPF**TL**S70D12*	26	200	250	2000	3000	400	133.3	66.8								
3ATPF**TL**S70D12*	34	200	250	2000	3000	400	138.8	69.6								
3ATPF**TL**S70D12*	39	200	250	2000	3000	400	142.8	71.6								
3ATPF**TL**S70D12*	43	200	250	2000	2800	400	145.3	72.8								
3ATPF**TL**S70D12*	51	200	250	2000	2400	400	151.3	75.8								
3ATPF**TL**S70D12*	60	180	230	1500	2800	400	157.8	79.1								
3ATPF**TL**S70D12*	70	180	200	1500	2500	400	164.8	82.5	58.7	28.4	33	7/16 14UNC -2B	26.2	52.4	27	
3ATPF**TL**S70D12*	78	160	200	1500	2300	400	171	85								
3ATPF**TL**S70D12*	89	140	180	1500	2000	400	176	88								

Dimensions

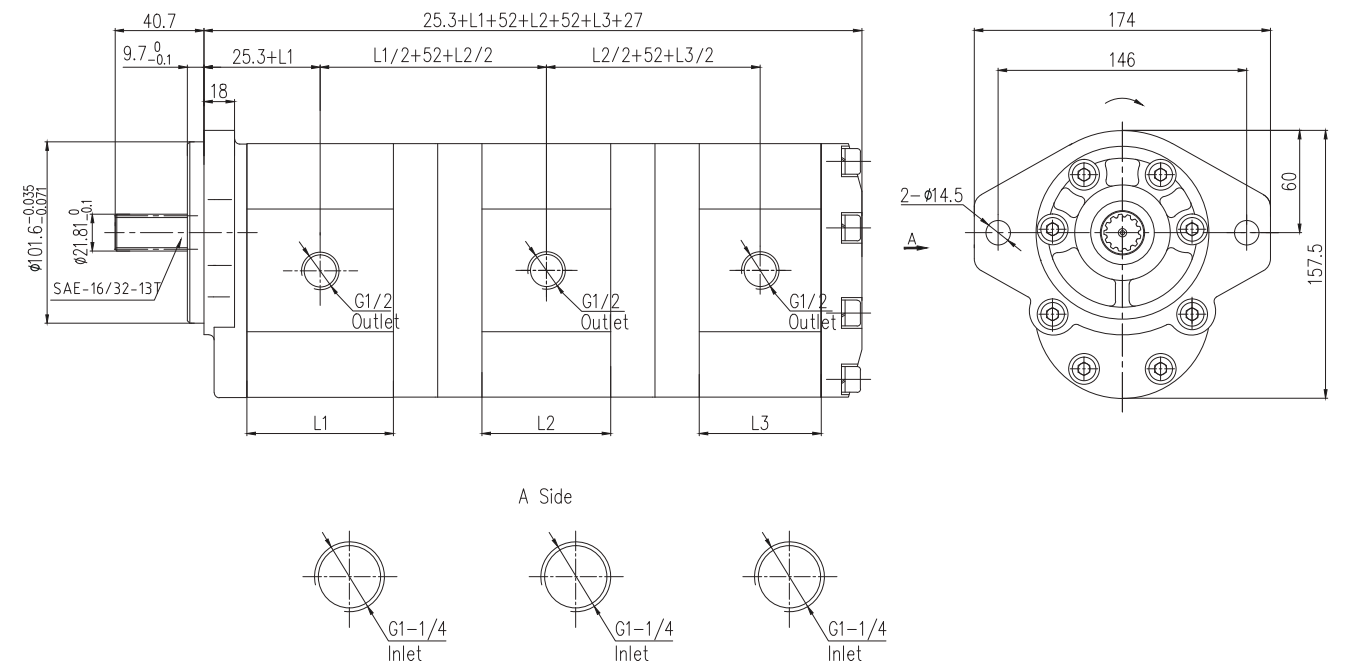

Application Guide of Tandem Pump Connection - Assemble Step

2ABDPF**F*****-TS Only for Tandem Pump or Triple Pump

Step 1 2ABPF-F*****-TSF Step 2 2ABPF-F*****-TSM Step 3 2ABPF-F*****-TSR

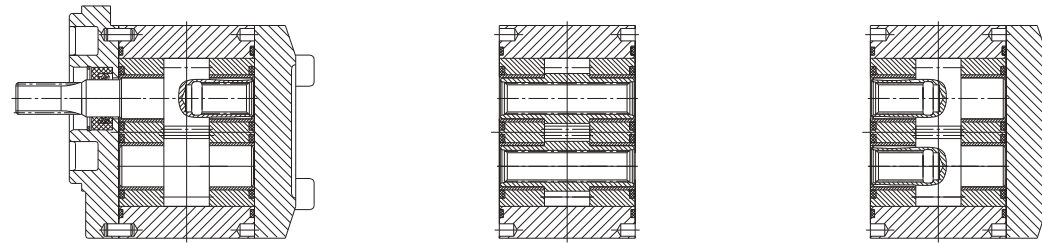

Step 4 Add Kit 2ABPF-TS-K

Plate Pin Spline

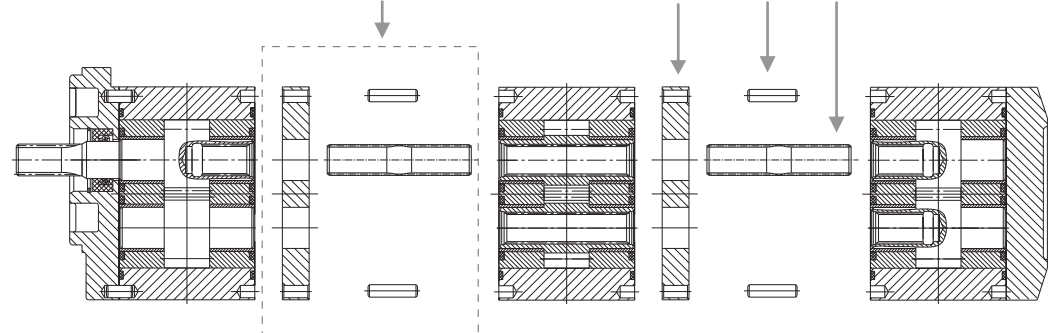

Long Bolts

Step 5 Tighten Bolt 4 × M10/70Nm

To remove 4 × M10 Short Bolt and stare using

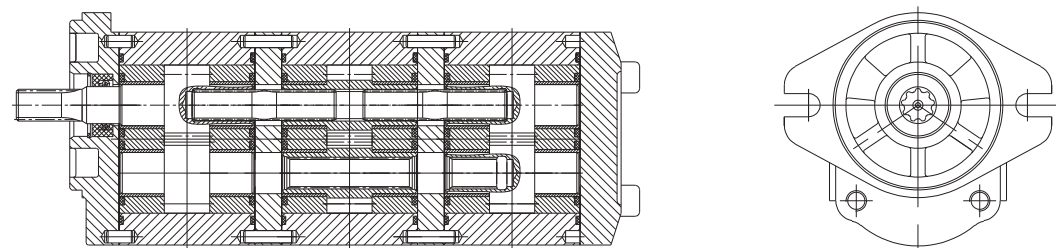

Exploded View

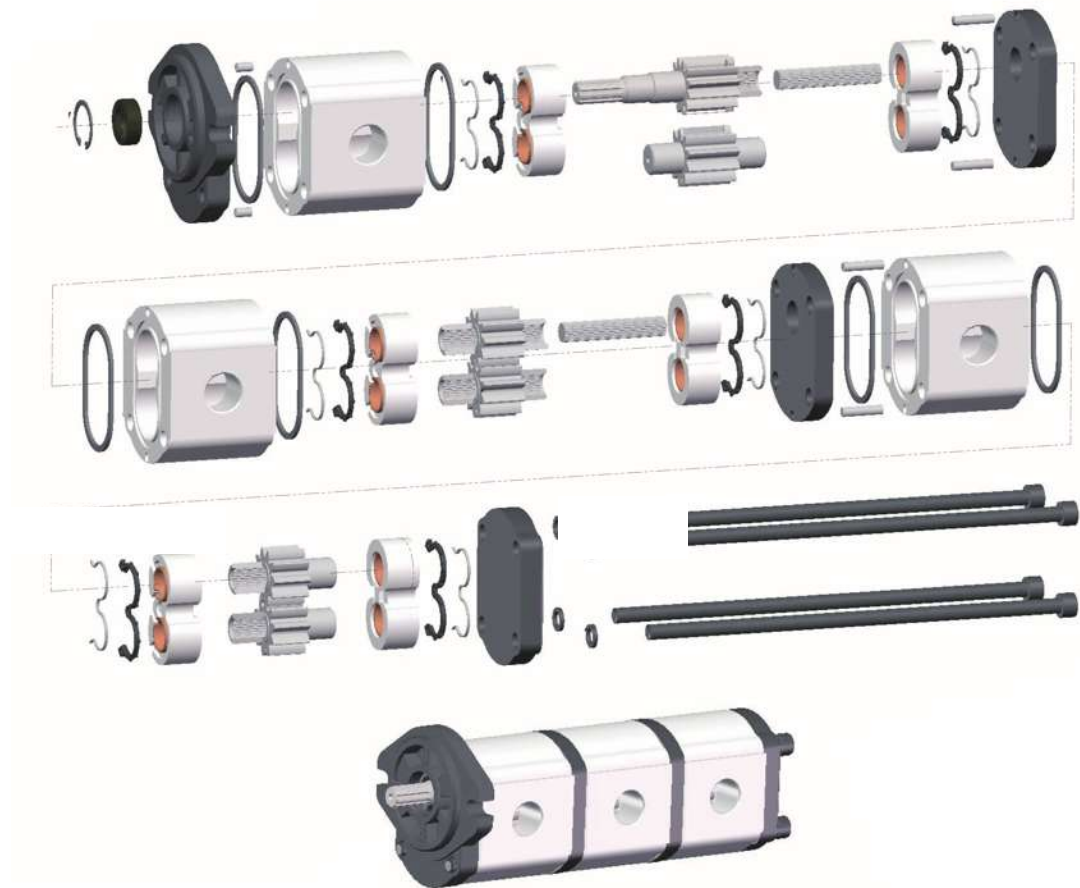

Order Code

Sequence	Name	Order Code	Number	Notes
1	Gear Pump	2ABPF**F*****-TSF	1	Front Pump
2	Gear Pump	2ABPF**F*****-TSM	1	Middle Pump
3	Gear Pump	2ABPF**F*****-TSR	1	Rear Pump
4	Kit	2ABPF-TS-K1	1	Used in Double Pump or Triple Pump
4.1	Pin	2ABPF-TS-KP	2	
4.2	Plate	2ABPF-TS-KPL	1	
4.3	Spline	2ABPF-TS-KSP	1	
5	Bolt		4	According to the displacement

2BDPF**F*****-TK Single Pump Available

STEP 1 2BPF**F*****-TK

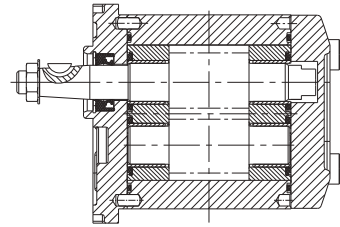

STEP 2 2BPF**F*****-TK

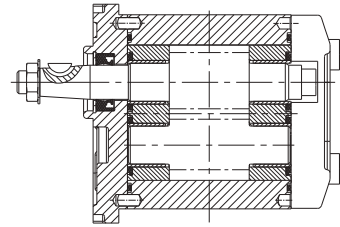

Step 3 Add Kit 2BPF-TK-K

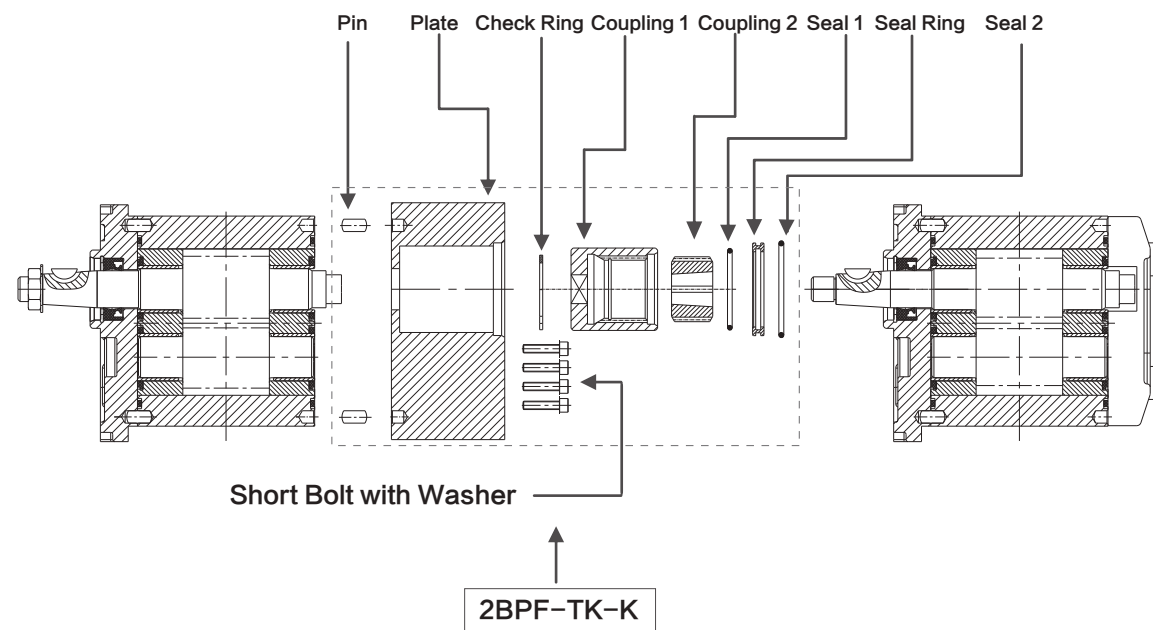

Step 4 Tighten Bolt 4 × M8/40Nm

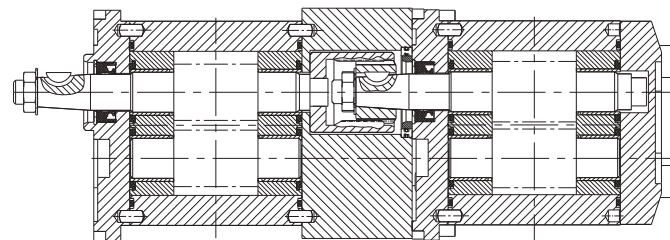

Exploded View

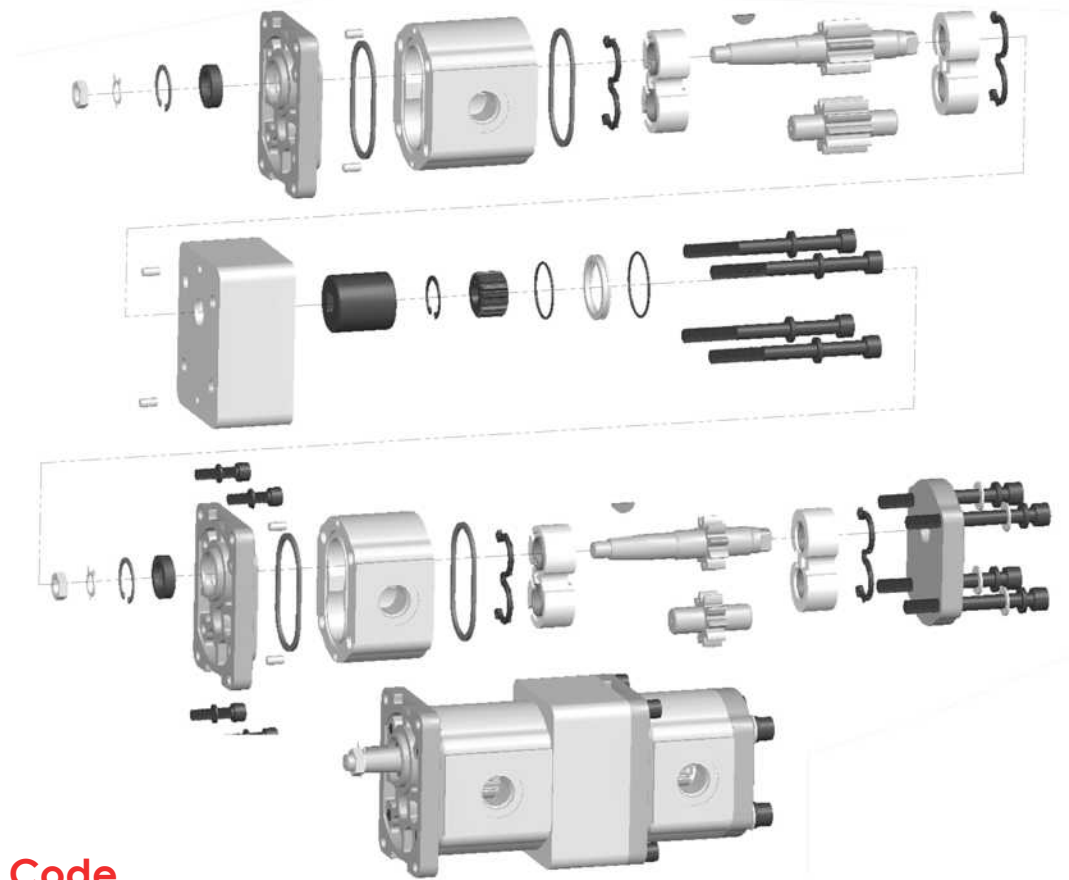

Order Code

Sequence	Name	Order Code	Number	Notes
1	Gear Pump	2BPF**F*****-TK	1	Front Pump
2	Gear Pump	2BPF**F*****-TK	1	Rear Pump
3	Kit	2BPF-TK-K	1	
3.1	Pin	2BPF-TK-KP	2	Used in 2BPF-TK-K
3.2	Plate	2BPF-TK-KBL	1	Used in 2BPF-TK-K
3.3	Check Ring	2BPF-TK-KBL	1	Used in 2BPF-TK-K
3.4	Coupling 1	2BPF-TK-KC1	1	Used in 2BPF-TK-K
3.5	Coupling 2	2BPF-TK-KC2	1	Used in 2BPF-TK-K
3.6	Seal 1	2BPF-TK-KS1	1	Used in 2BPF-TK-K
3.7	Seal 2	2BPF-TK-KS2	1	Used in 2BPF-TK-K
3.8	Seal Ring	2BPF-TK-KSR	1	Used in 2BPF-TK-K
3.9	Bolt with Washer	2BPF-TK-KB	4	Used in 2BPF-TK-K

2ABDPF**F*****-XK Only for Tandem Pump

Step 1 2ABPF**F*****-XKF

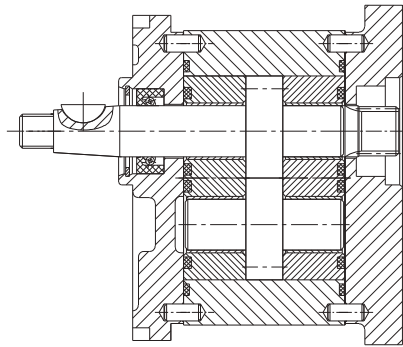

Step 2 2ABPF**F*****-XKR

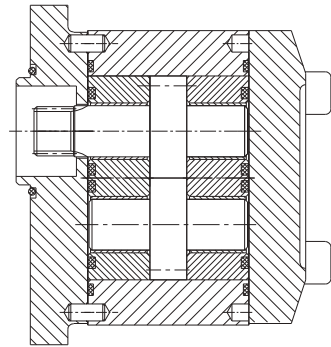

Step 4 Add 2ABPF-XK-K (Nuts 4 × M10 / Washer 4 × φ 11/ Coupling 1/ Bolt 4 × M10)

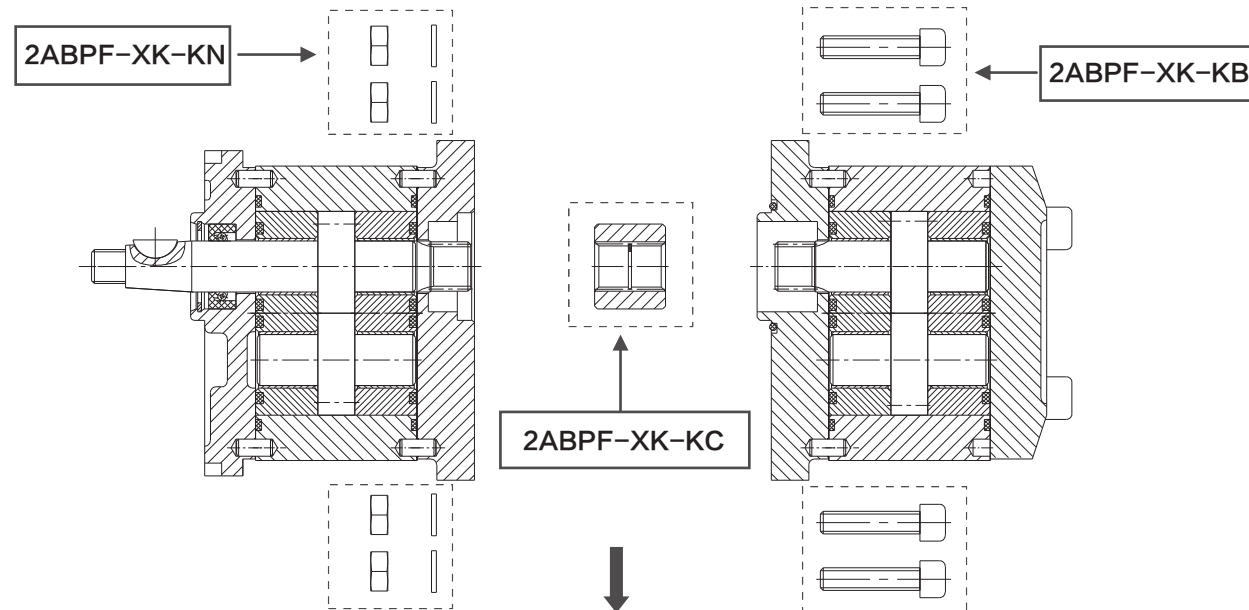

Step 5 Tighten Bolt 4 × M8/40Nm

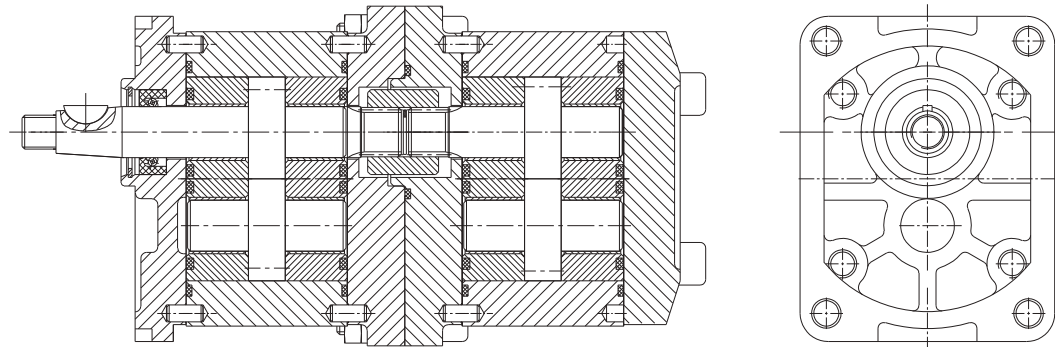

Exploded View

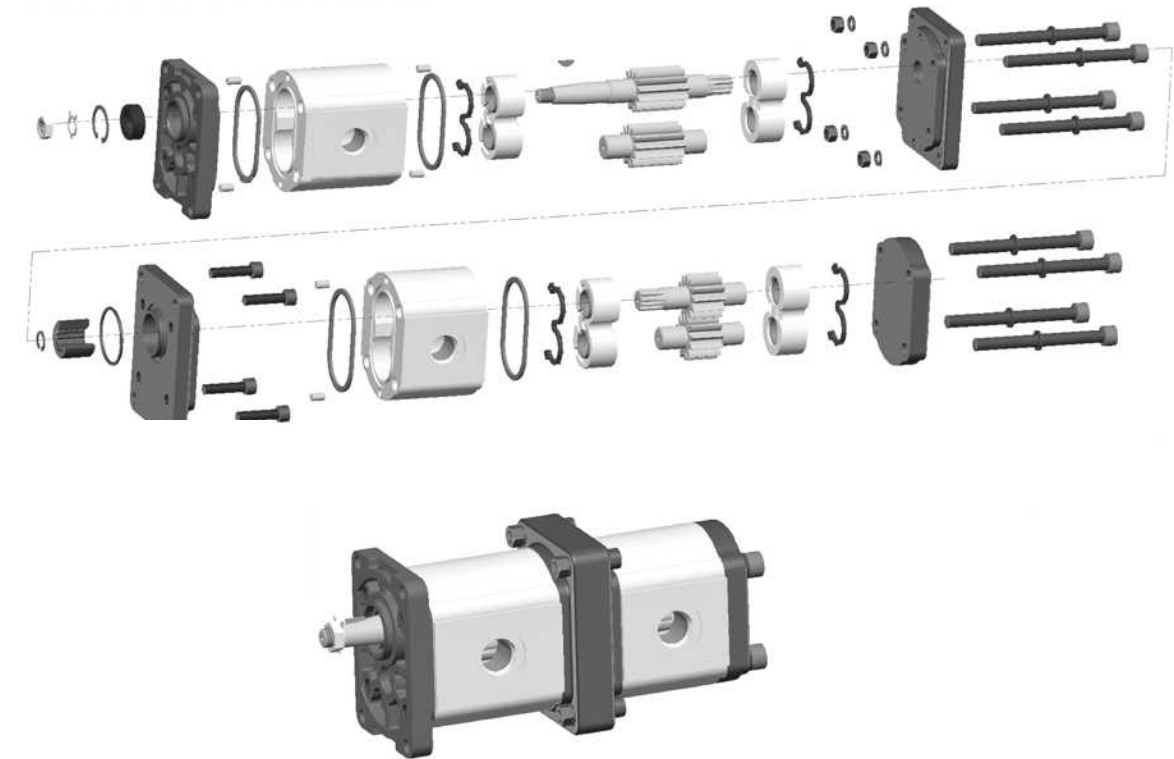

Order Code

Sequence	Name	Order Code	Number	Notes
1	Gear Pump	2ABPF**F*****-XKF	1	Front Pump
2	Gear Pump	2ABPF**F*****-XKR	1	Rear Pump
3	Kit	2ABPF-XK-K	1	Nuts × 4 / Whsher × 4 / Coupling × 1 / Bolt × 4
3.1	Nu	2ABPF-XK-KN	4	Used in 2ABPF-XK-K
3.2	Coupling	2ABPF-XK-KC	1	Used in 2ABPF-XK-K
3.3	Bolt	2ABPF-XK-KB	4	Used in 2ABPF-XK-K

2ABDPF**F*****-FK Single Pump Available

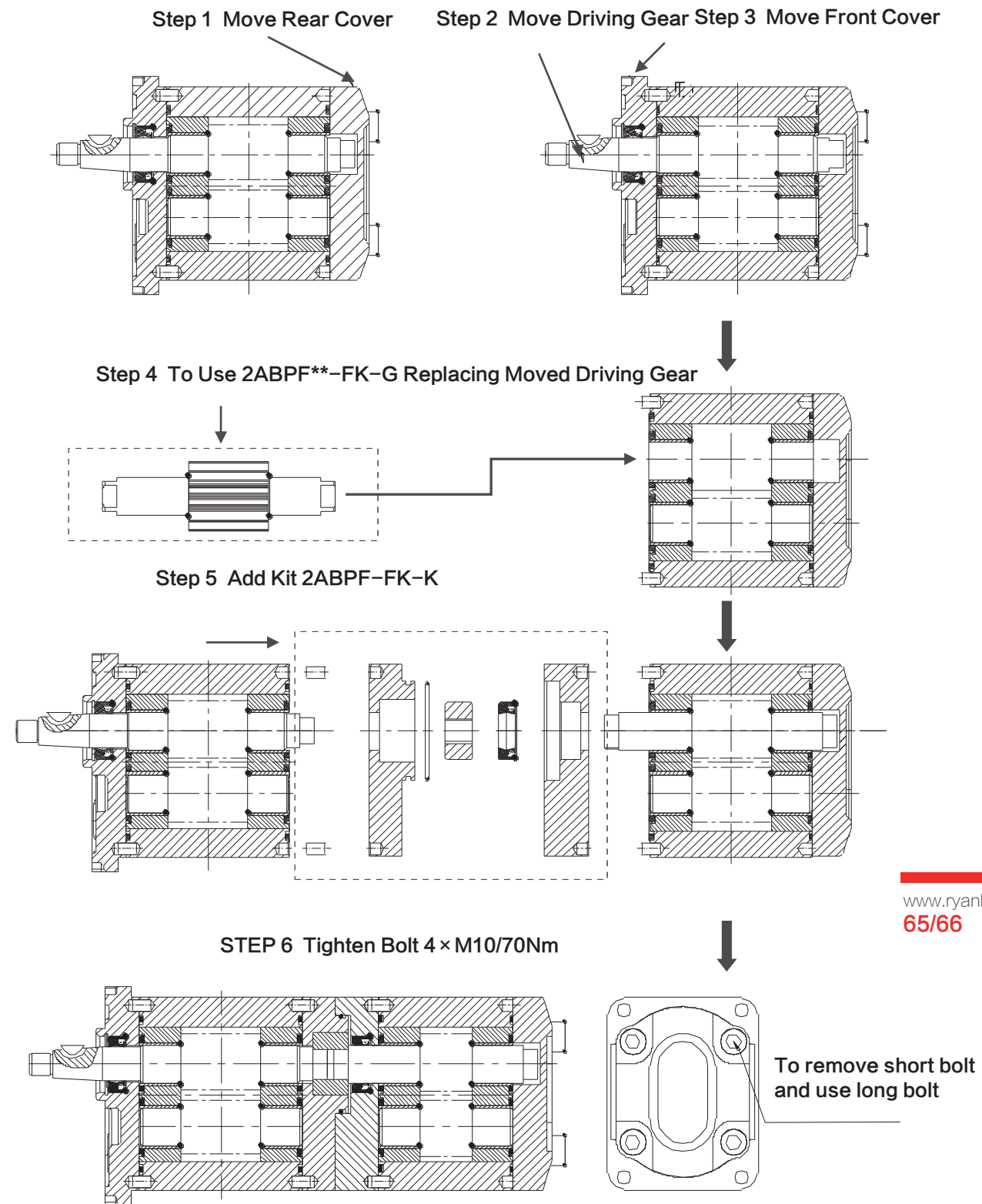

Exploded View

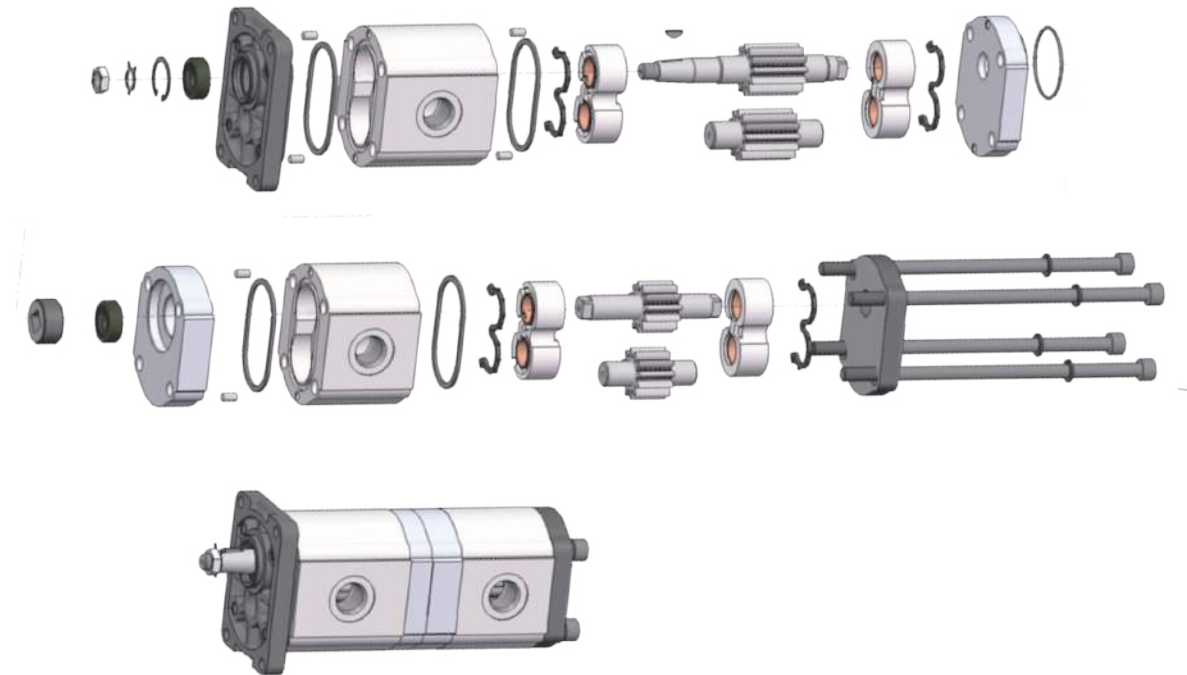

Order Code

Sequence	Name	Order Code	Number	Notes
1	Gear Pump	2ABPF**F*****-TK	1	Front Pump
2	Gear Pump	2ABPF**F*****-TK	1	Rear Pump
3	Gear	2ABPF**-FK-G	1	**—cc/r
4	Kit	2ABPF-FK-K	1	
4.1	Pin	2ABPF-FK-KP	2	Used in 2ABPF-FK-K
4.2	Plate 1	2ABPF-FK-KPL1	1	Used in 2ABPF-FK-K
4.3	Seal	2ABPF-FK-KS	1	Used in 2ABPF-FK-K
4.4	Coupling	2ABPF-FK-KC	1	Used in 2ABPF-FK-K
4.5	Shaft Seal	2ABPF-FK-KSS	1	Used in 2ABPF-FK-K
4.6	Plate 2	2ABPF-FK-KPL2	1	Used in 2ABPF-FK-K
5	Bolt		4	According to the displacement

Cast Iron pumps

1	E	P	F	73	L01	F75	D9	L-	SS	F
a	b	c	d	e	f	g	h	i	j	k

- Ⓐ 1=Group
1、 2、 2.5、 3、 3.5、 4 Group
- Ⓑ E/Y/C=Cast Iron Pump
- Ⓒ Function
P=Gear Pump
D=Double Pump
T=Triple Pump
- Ⓓ Pressure Rate
E=160bar
F=200bar
G=250bar
- Ⓔ Displacement=1.6 ~ 199cc/r
- Ⓕ L01=Port
- Ⓖ F75=Shaft

- Ⓗ D9=Front Covers
- Ⓘ Rotation
R=CW
L=CCW
B=Bi-directional
- Ⓚ Ports Combination
SS=side inlet and side outlet
SB=side inlet and back outlet
BS=back inlet and Side outlet
BB=back inlet and back outlet
- Ⓛ Seal
F=FKM Seal
Omit=NBR Seal

Ⓕ Line ports Inlet/Outlet		Ⓖ Drive shafts		Ⓗ Front covers	
LJ35	3/4-16UNF-2B 9/16-18UNF-2B	O9	Oblate shaft Ø4.37mm x 8	S2	4-groove mounting 50.8x50.8mm
L00	G1 G1	S70	Splined shaft 13teeth 21.81mm	D9	2-groove mounting Ø106mm
F97	52.4x26.2,M10,Ø25 47.6x22.2,M10,Ø19	F75	Flat keyed shaft Ø19.05mm	D14	6-hole mounting 89.81mm, 146.05mm
F104	52.4x26.2,M10,Ø25 52.4x26.2,M10,Ø25	S57	Splined shaft 11teeth 18mm	SP9	4-hole mounting Ø113x113mm

1EPF**L35O9S2*SS-YD With Relief Valve

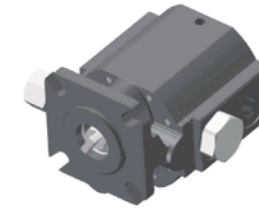

Model	Displacement cc/r	Pressure(bar)		Speed(r/min)			Port	
		Rated	Peak	Rated	Max	Min	Inlet	Outlet
1EPF1.6L35O9S2SS-YD	1.6	160	200	2000	4500	500	3/4-16UNF -2B	9/16-18UNF -2B
1EPF2.7L35O9S2SS-YD	2.7	160	200	2000	4500	500		
1EPF4.1L35O9S2SS-YD	4.1	160	200	2000	4500	500		
1EPF6.1L35O9S2SS-YD	6.1	160	200	2000	4500	500		

Dimensions

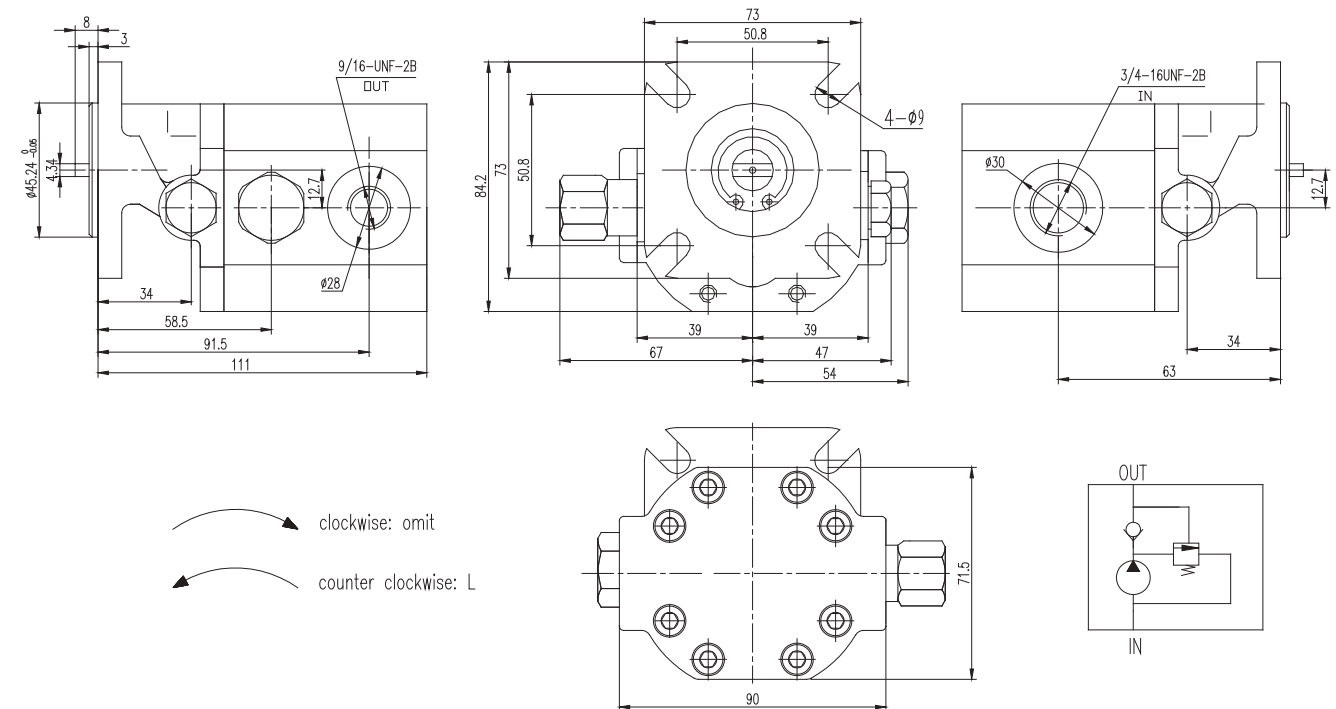

2YBDPF**DF**S57S12*

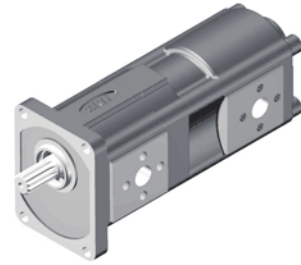

Model	Displacement (ml/r)		Pressure(bar)				Speed(r/min)		
			Front Pump		Rear Pump				
	Front Pump	Rear Pump	Rated	Peak	Rated	Peak	Rated	Max	Min
2YBDPF20/10DF54S57S12*	20	10	200/250	250/300	200/250	250/300	2500	3000	800

Dimensions

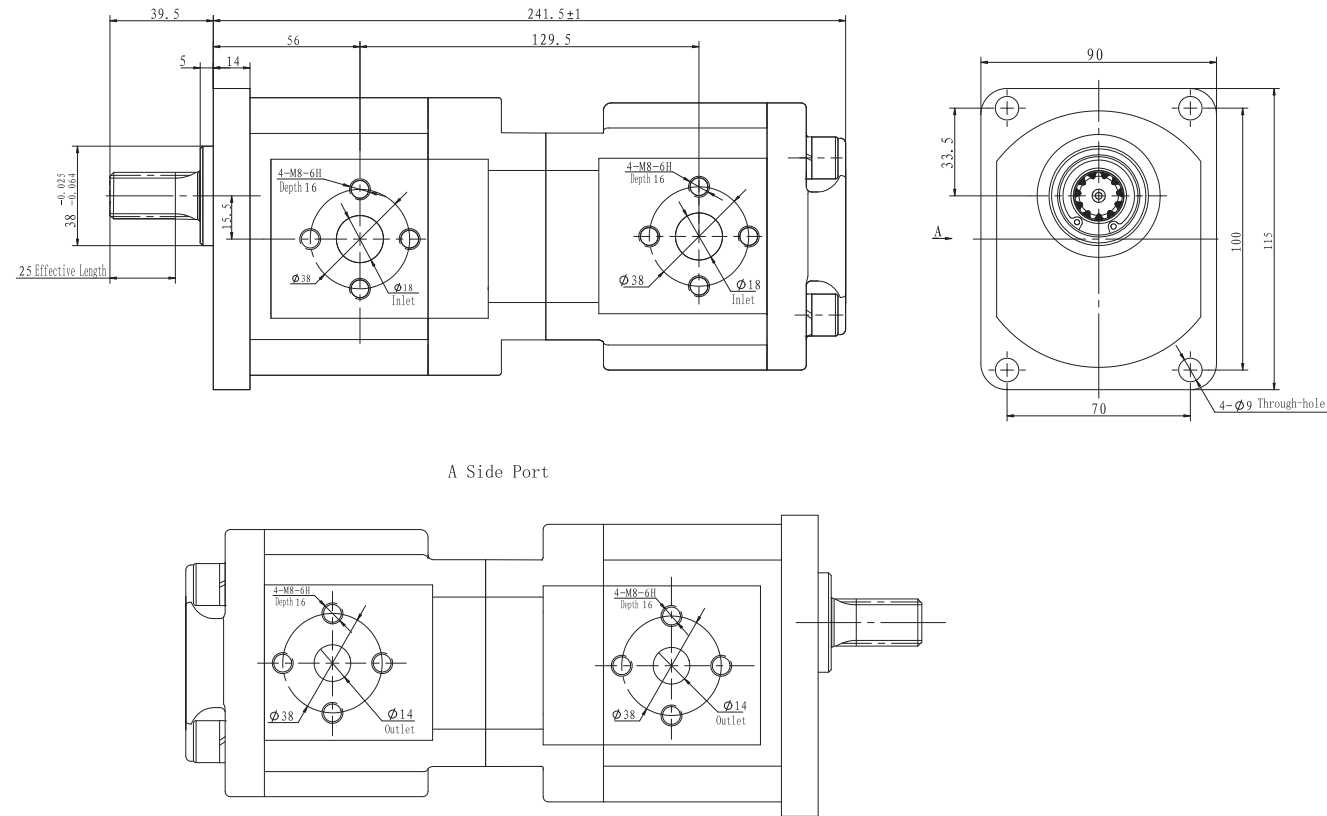

2.5YPF25F97F75D9*



Model	Displacement (ml/r)	Pressure(bar)		Speed(r/min)			Inlet			Outlet		
							Rated	Peak	Rated	Peak	Min	L1xB1
		2.5YPF25F97F75D9*	25	250	280	1500	2500	500	52.4 X 26.2	M10	Ø25	47.6 X 22.2

Dimensions

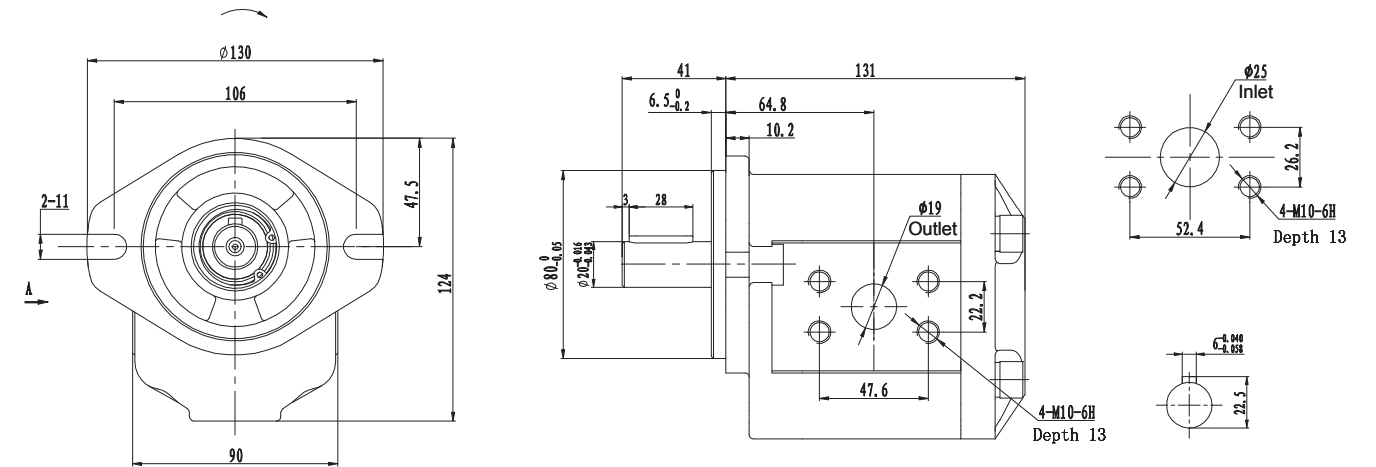

2.5EPF **LF104D11-O***



Model	Displacement (ml/r)	Pressure(bar)		Speed(r/min)			L (mm)	L1 (mm)
		Rated	Peak	Rated	Max	Min		
2.5EPF 10.16L**F104D11-O*	10.16	210	250	2000	3000	600	137	112
2.5EPF 15.23L**F104D11-O*	15.23	210	250	2000	3000	600	143.5	118.5
2.5EPF 20.31L**F104D11-O*	20.31	210	250	2000	3000	600	150	125
2.5EPF 25.39L**F104D11-O*	25.39	210	250	2000	3000	600	156.5	131.5
2.5EPF 30.47L**F104D11-O*	30.47	210	250	2000	3000	600	163	138
2.5EPF 35.54L**F104D11-O*	35.54	180	210	2000	3000	600	169.5	144.5
2.5EPF 40.62L**F104D11-O*	40.62	180	210	2000	3000	600	176	151

Dimensions

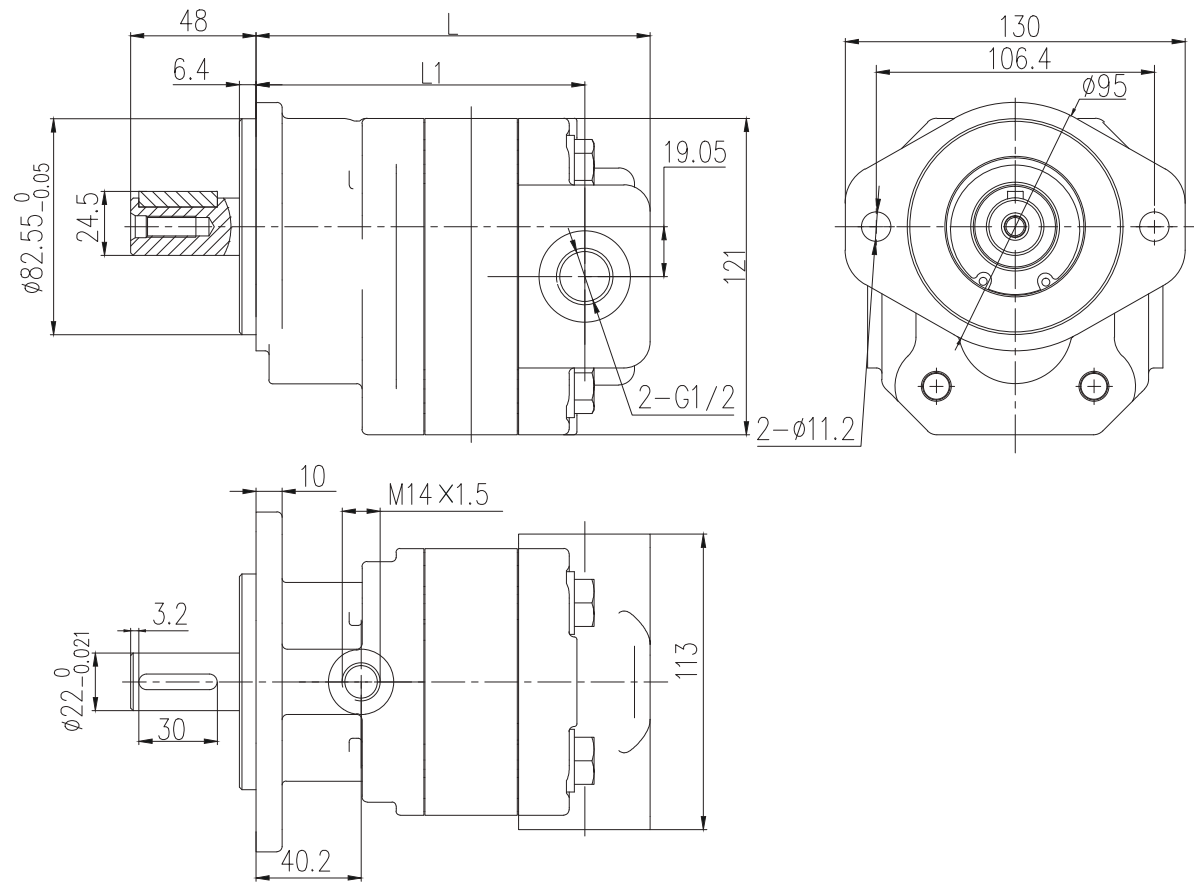

3CPFL**R16S22**



Model	Displacement (ml/r)	Pressure(bar)		Speed(r/min)			A (mm)	B (mm)	D (mm)	d (mm)	Weight (kg)
		Rated	Peak	Rated	Max	Min					
3CPF43L03R16S22	43	210	300	2000	3000	300	171	115.5	G1	G3/4	12.8
3CPF51L00R16S22	51	210	300	2000	3000	300	177	118.5	G1	G1	13.2
3CPF61L00R16S22	61	210	300	200	3000	300	183.6	121.8	G1	G1	13.6
3CPF82L11R16S22	82	210	300	200	3000	300	196	128	G1-1/4	G1	14.1

Dimensions

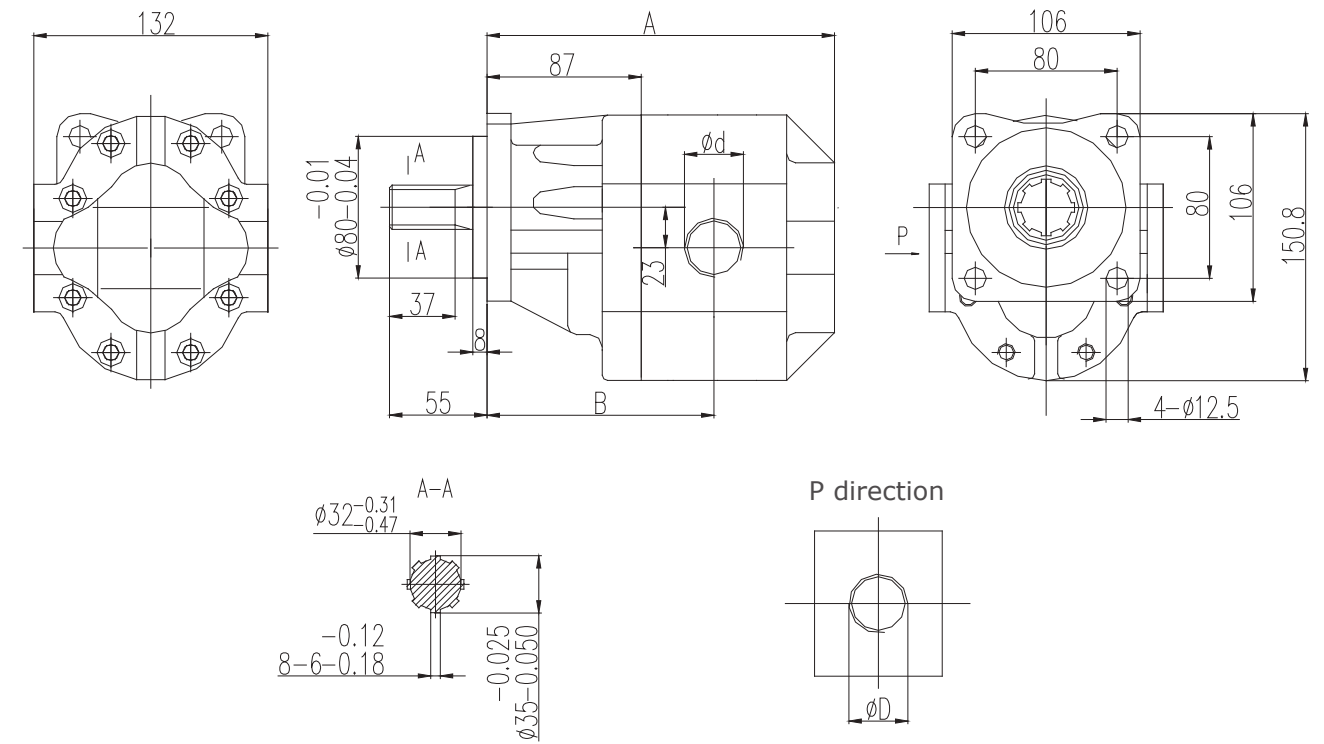

3.5EPFL**R16S22B**



Model	Displacement (ml/r)	Pressure(bar)		Speed(r/min)			A (mm)	B (mm)	D (mm)	d (mm)
		Rated	Peak	Rated	Max	Min				
3.5EPF82L00R16S22B	82	210	300	2000	3000	300	233	157.5	G1	G1
3.5EPF95L99R16S22B	95	210	300	2000	3000	300	239	160.5	G1-1/4	G1-1/4

Dimensions

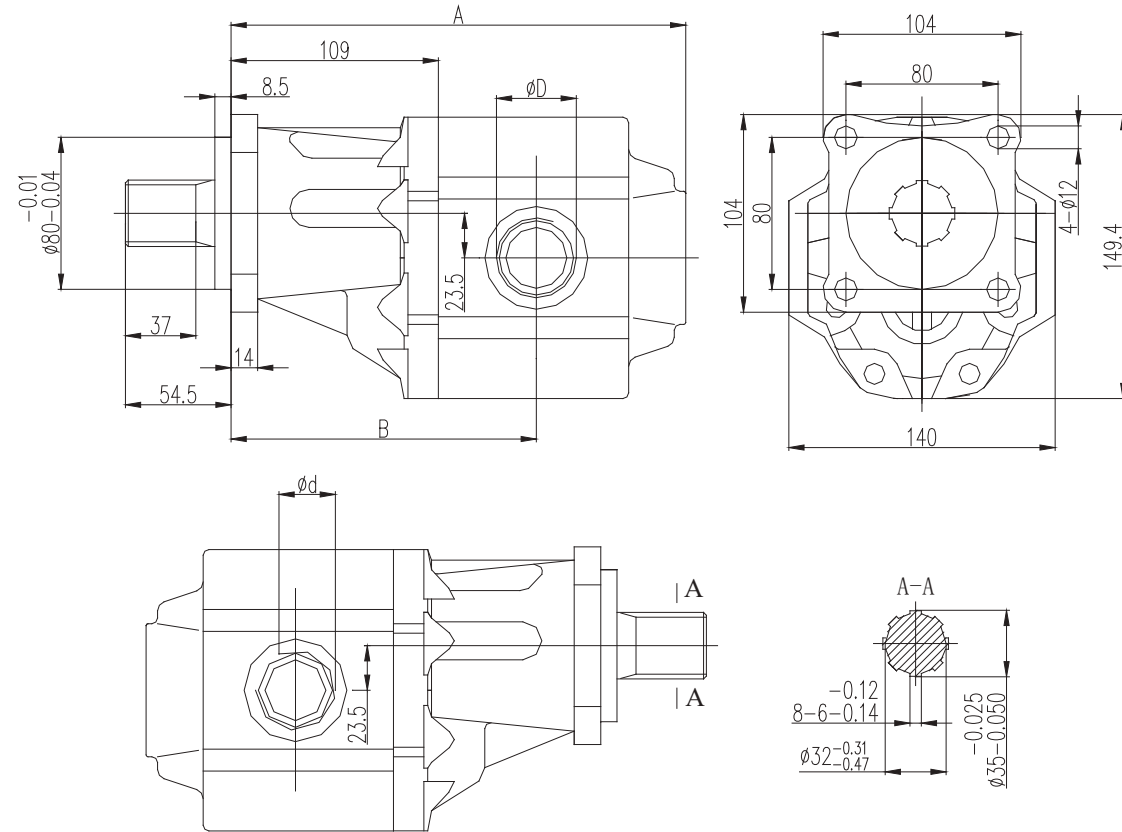

3.5APFF108F102S73SP9-B-O**



Model	Displacement (ml/r)	Pressure(bar)		Speed(r/min)			L (mm)	L1 (mm)	T1 (mm)	T2 (mm)
		Rated	Peak	Rated	Max	Min				
3.5APF52F108F102S73SP9-B-O	52	170	210	1500	3600	600	181.0	206.5	1"	1-1/4"
3.5APF63F108F102S73SP9-B-O	63	170	210	1500	3600	600	187.5	216.0	1"	1-1/4"
3.5APF73F108F102S73SP9-B-O	73	170	210	1500	3600	600	193.5	225.3	1-1/4"	1-1/4"
3.5APF85F108F102S73SP9-B-O	85	150	180	1500	3600	600	200.5	235.5	1-1/4"	1-1/4"
3.5APF93F108F102S73SP9-B-O	93	150	180	1500	3600	600	206.5	244.5	1-1/2"	1-1/4"
3.5APF104F108F102S73SP9-B-O	104	150	180	1500	3600	600	213.0	254.5	1-1/2"	1-1/4"
3.5APF115F108F102S73SP9-B-O	115	120	140	1500	3600	600	219.0	263.5	1-1/2"	1-1/4"

Dimensions

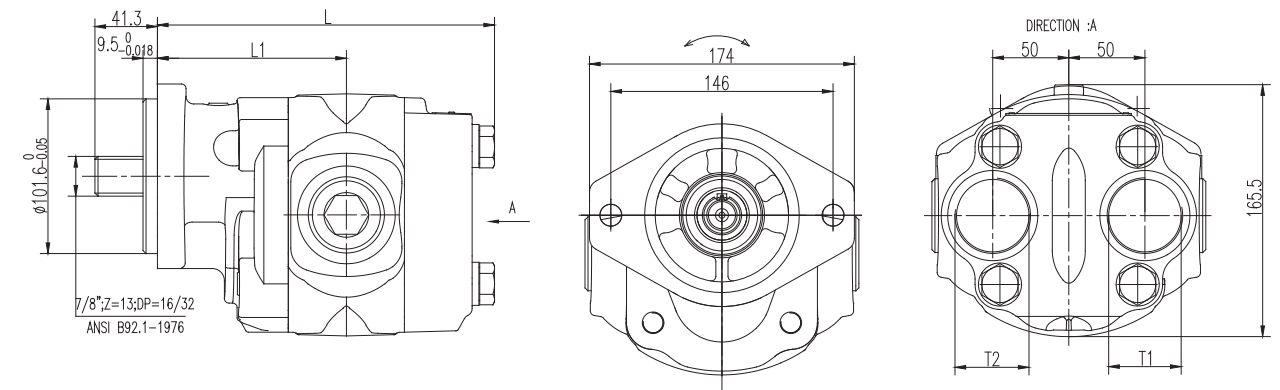

3.5APFL**S84D14*-B-O**



Model	Displacement (ml/r)	Pressure(bar)		Speed(r/min)			L (mm)	L1 (mm)	T1 (mm)	T2 (mm)
		Rated	Peak	Rated	Max	Min				
3.5APF52L**S84D14-B-O	52	170	210	1500	3600	600	181.0	206.5	1"	1-1/4"
3.5APF63L**S84D14-B-O	63	170	210	1500	3600	600	187.5	216.0	1"	1-1/4"
3.5APF73L**S84D14-B-O	73	170	210	1500	3600	600	193.5	225.3	1-1/4"	1-1/4"
3.5APF85L**S84D14-B-O	85	150	180	1500	3600	600	200.5	235.5	1-1/4"	1-1/4"
3.5APF93L**S84D14-B-O	93	150	180	1500	3600	600	206.5	244.5	1-1/2"	1-1/4"
3.5APF104L**S84D14-B-O	104	150	180	1500	3600	600	213.0	254.5	1-1/2"	1-1/4"
3.5APF115L**S84D14-B-O	115	120	140	1500	3600	600	219.0	263.5	1-1/2"	1-1/4"

Dimensions

3.5APFL**S70D15-B-O**

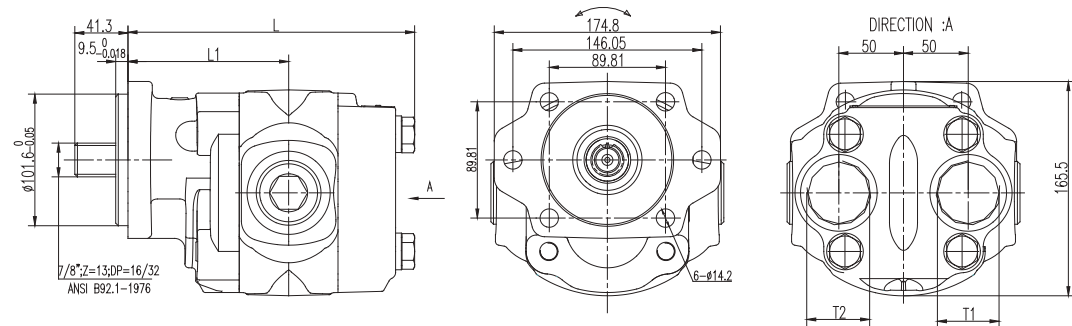

3.5BPFF108F102S73SP9-B-O**

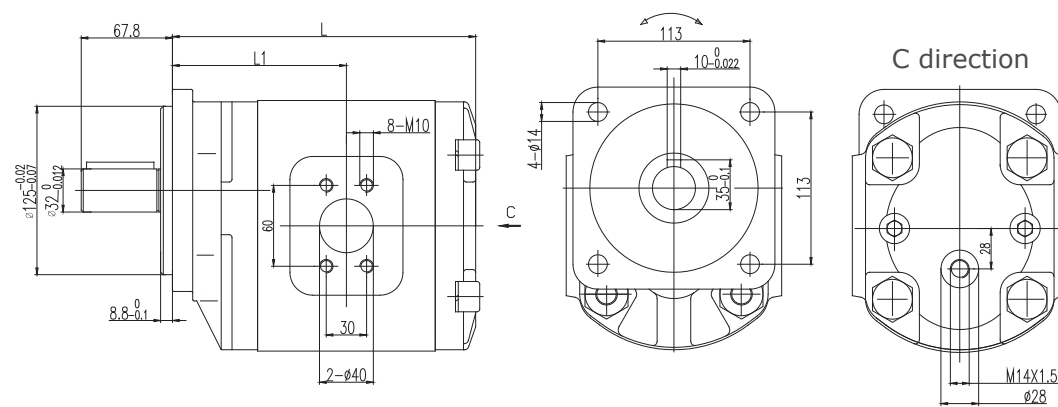

4PF **FS83S20L**



Model	Displacement (ml/r)	Pressure(bar)		Speed(r/min)			L (mm)	L1 (mm)
		Rated	Peak	Rated	Max	Min		
4PF66F161S83S20L	66	210	250	1800	2200	600	197.3	121
4PF83F161S83S20L	83	210	250	1800	2200	600	203.5	124.1
4PF91F161S83S20L	91	210	250	1800	2200	600	207.3	126
4PF99F161S83S20L	99	210	250	1800	2200	600	209.8	127.2
4PF116F161S83S20L	116	210	250	1800	2200	600	217.3	130.9
4PF132F161S83S20L	132	210	250	1800	2200	600	222.6	133.5
4PF145F161S83S20L	145	210	250	1800	2200	600	227.8	136.1
4PF149F161S83S20L	149	210	250	1800	2200	600	229.3	136.8
4PF166F161S83S20L	166	210	250	1800	2200	600	235.3	139.8
4PF182F161S83S20L	182	180	210	1800	2200	600	241.3	142.8
4PF199F161S83S20L	199	180	210	1800	2200	600	248.3	146.3

Dimensions

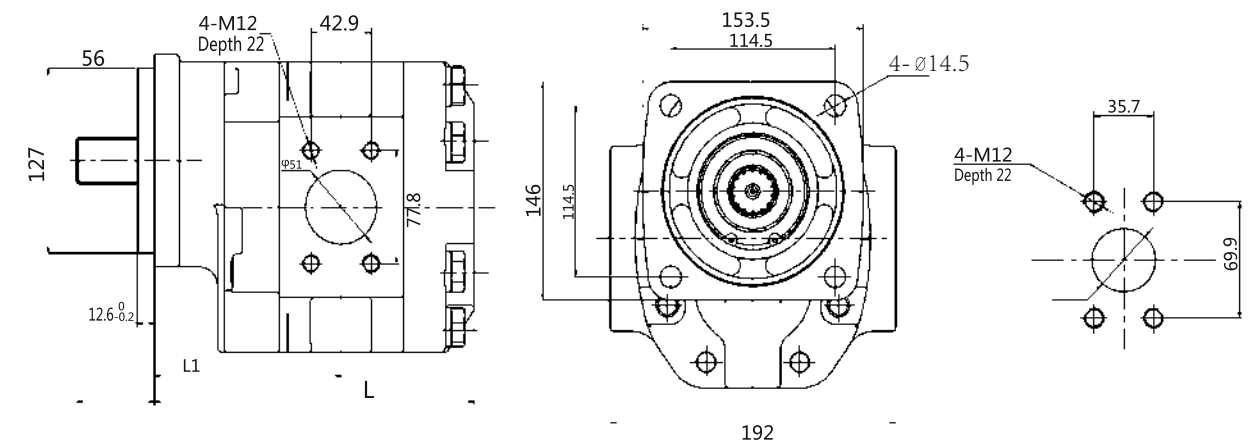

XTYBA Gear Pumps



Model	Displacement (ml/r)	Pressure(bar)		Speed(r/min)	
		Rated	Peak	Rated	Max
XTYBA	10	20	30-50	1500	2500

Dimensions

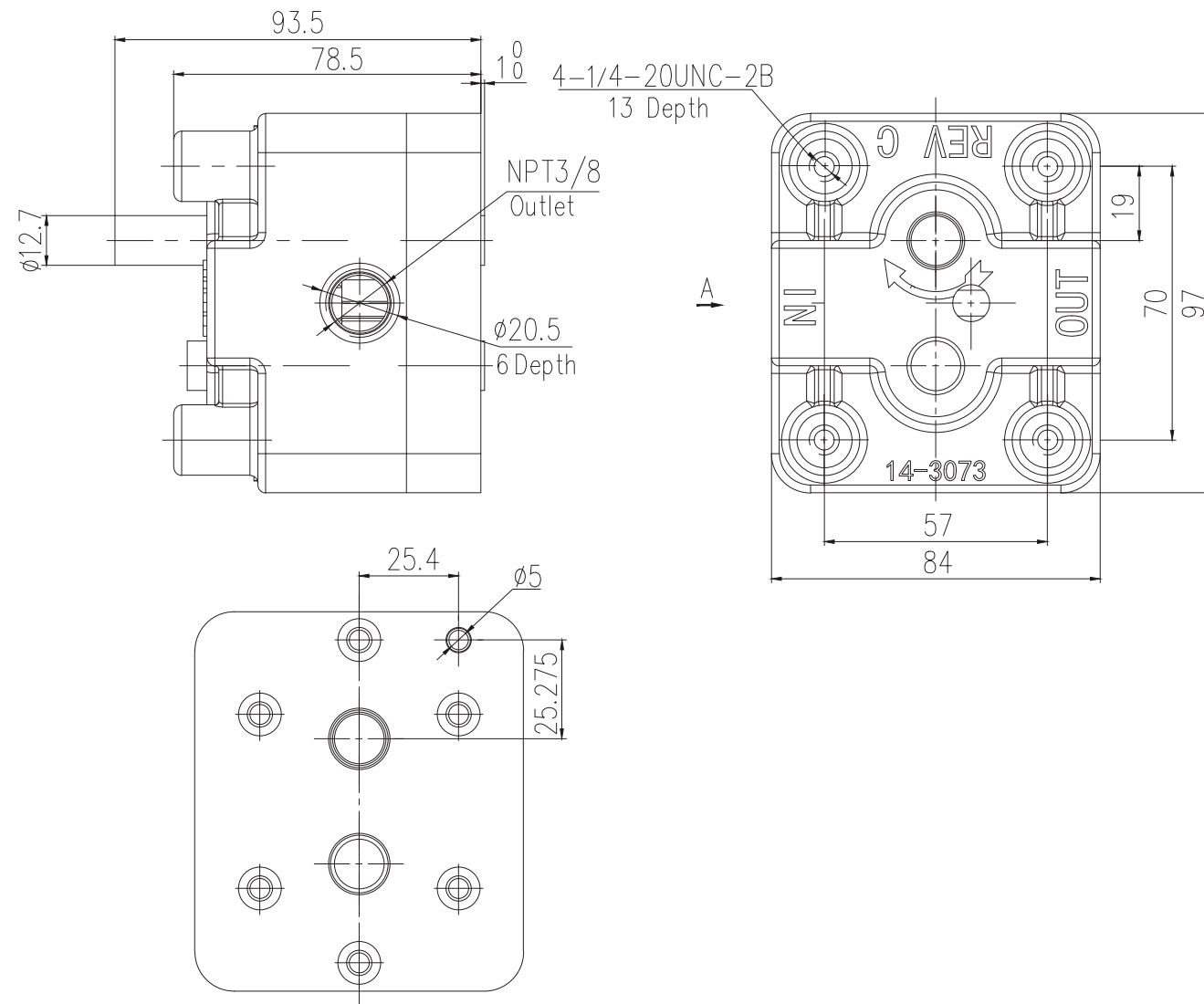

C101 C102 G101 G102 Series Dump Pumps



Model	Teeth Width(in)	Displacement (ml/r)	Pressure(bar)		Speed(r/min)		Input Power (Kw)	Features
			Rated	Peak	Peak	Min		
C101-20-MS/AS-R	2	85	175	210	2400	600	78	Double Shaft
C101-25-MS/AS-R	2-1/2	105	175	210	2400	600	89	Double Shaft
C102-20-MS/AS-L	2	85	175	210	2400	600	78	Single Shaft
C102-25-MS/AS-L	2-1/2	105	175	210	2400	600	89	Single Shaft
G101-07-MS/AS-R	3/4	25	175	210	2400	600	27	Double Shaft
G101-20-MS/AS-R	2	65	175	210	2400	600	70	Double Shaft
G102-15-MS/AS-L	1-1/2	50	175	210	2400	600	89	Single Shaft
G102-20-MS/AS-L	2	65	175	210	2400	600	70	Single Shaft

Dimensions

C101 C102 Dump Pumps

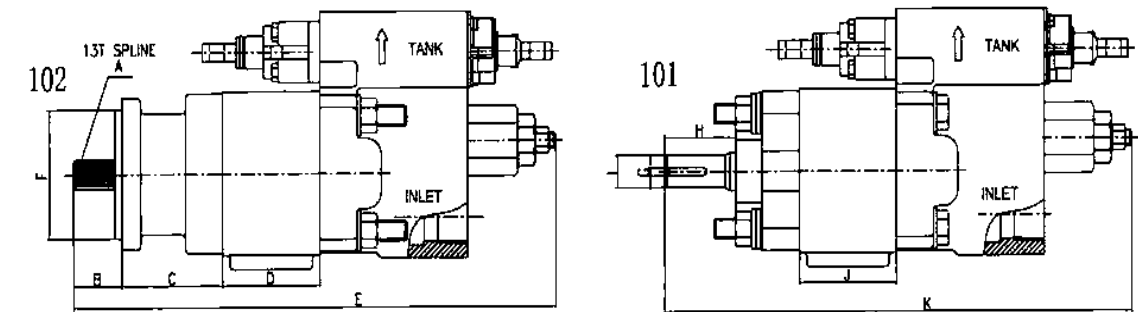

	A	B	C	D		E	D
G102	SAE B	1.62	2.94	1.50(07)	2.25(15)	2.75(20)	11.25+D
C102	SAE B	1.62	3.37	2.75(20)	3.25(25)		13.25+D

	G	H	I	J		K
G101	0.25	1.94	1.00	1.50(07)	2.25(15)	2.75(20)
C101	0.25	2.38	1.00	2.75(20)	3.25(25)	

Installation and Operation

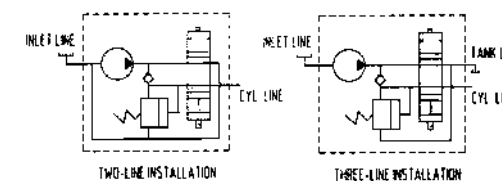

Air Shifters

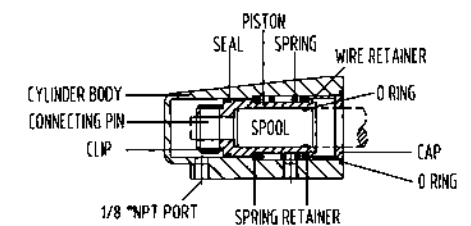

HGP19L10F103SP14



Model	Displacement (ml/r)	Pressure/(bar)		Speed(r/min)		Min flow at rated pressure and speed (L/min)	Rotation	Weight (Kg)
		Rated	Peak	Rated	Max			
HGP19L10F103SP14	10	50	70	200	1200			

Dimensions

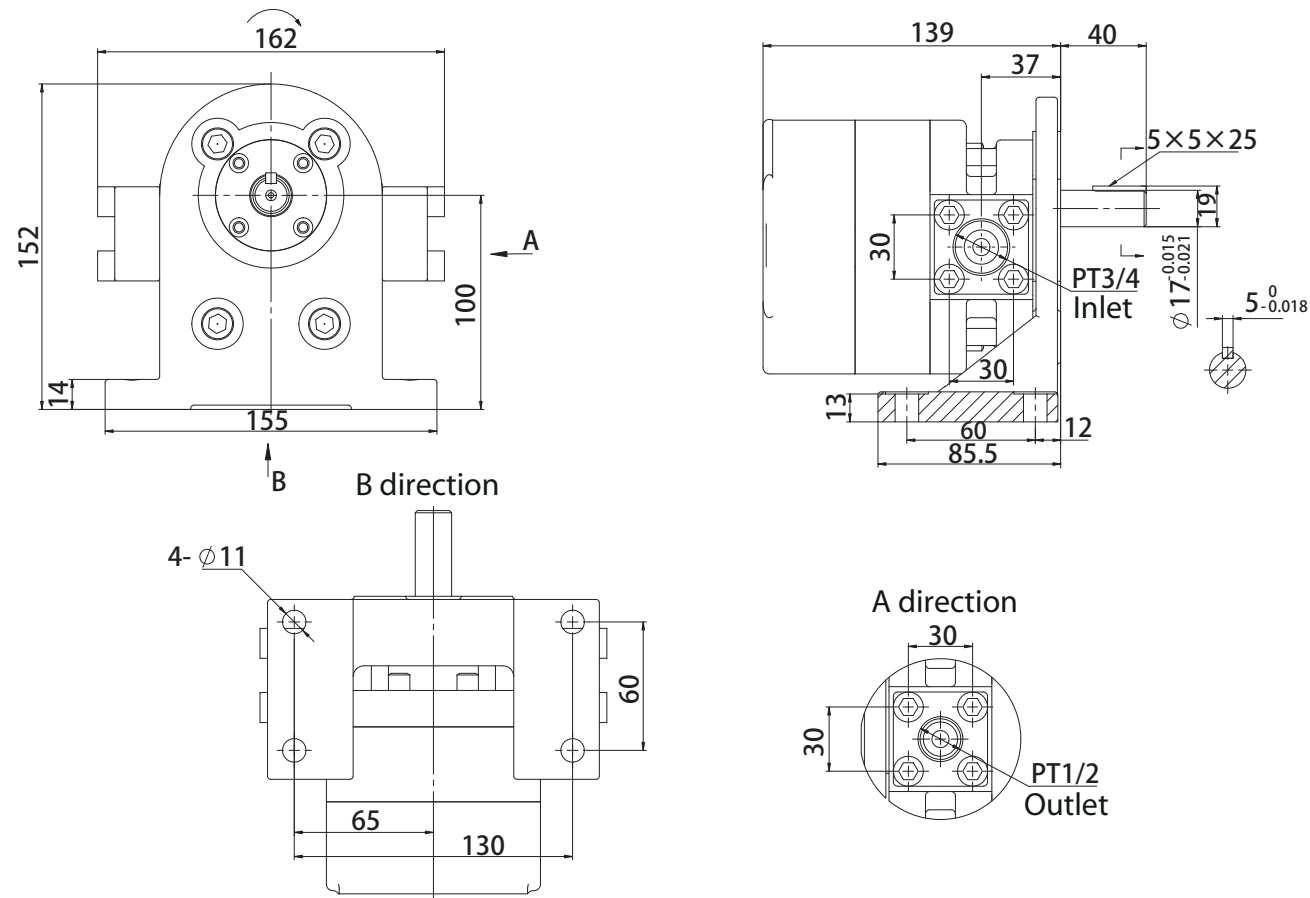

Cat Pumps

These pumps can be used in the hydraulic systems of bulldozer, loader, crane and other construction machineries.

Model	Displacement (ml/r)	Pressure(bar)		Speed(r/min)			Min flow at rated pressure and speed (L/min)	Rotation	Weight (Kg)
		Rated	Peak	Rated	Peak	Min			
3P4002	71	3	4	2000	2500	500	174	CW	15.5
3S4386	22	2.5	3.15	1500	2000	500	30	CW	19.4
7S4629	40	2.5	3.15	2000	2500	500	18	CCW	18.4
3P6816/3P0380	71	2.5	3.15	1800	2500	500	115	CW	19.4
3P6814	32	2.5	3.15	1800	2500	500	45	CW	18.4
2P9239	73.3	2.5	3.15	1800	2500	500	122	CW	15.5
3G4768	90	16	20	2000	2500	500	180	CCW	19.4
5M7864	28	2.5	3.15	2000	2500	500	45.6	CCW	18.4
5H1719	12	0.8	2	1500	2000	500	15	CCW	15.0
3N2078	16	2	3	1500	2000	500	19	CCW	19.4
4W5479	8	0.25	0.35	1500	2000	500	10.8	CCW	18.4
4W2448	Front: 62	2	3	1500	2000	500	109	CW	25
	Rear: 48	2	3				82		
9P9610	55	26	35	1800	2000	500	91.5	CCW	24.5
1233472	55	26	35	1800	2000	500	91.5	CCW	22.3
9U9535	65	26	35	1800	2000	500	108	CCW	26.5
7G4856	47	26	35	1800	2000	500	78	CCW	23.2
8E1217	73	26	35	1800	2000	500	121.5	CCW	31.5
119294	47.5	26	35	1500	2500	500	66	CW	5
1226658	55	26	35	1800	2000	500	91.5	CCW	25.2

3P4002/3S4386/7S4629 Gear Pumps

3P4002 Dimensions

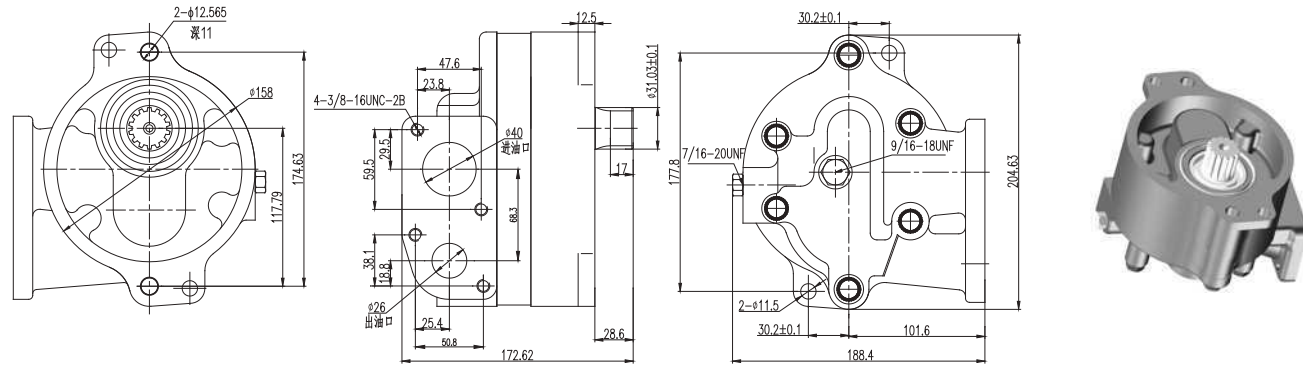

3S4386 Dimensions

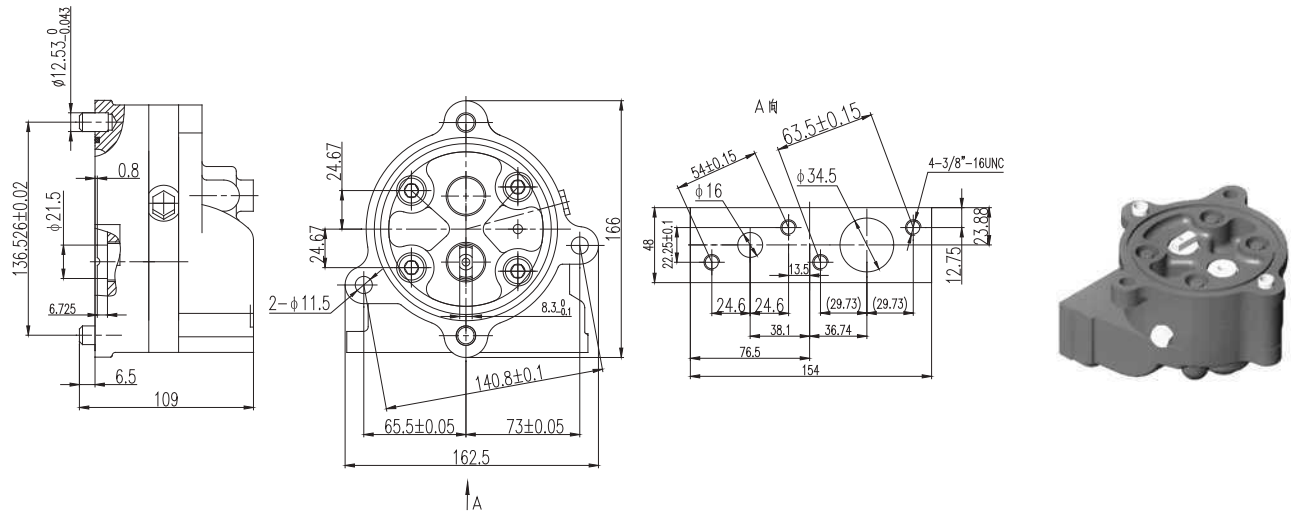

7S4629 Dimensions

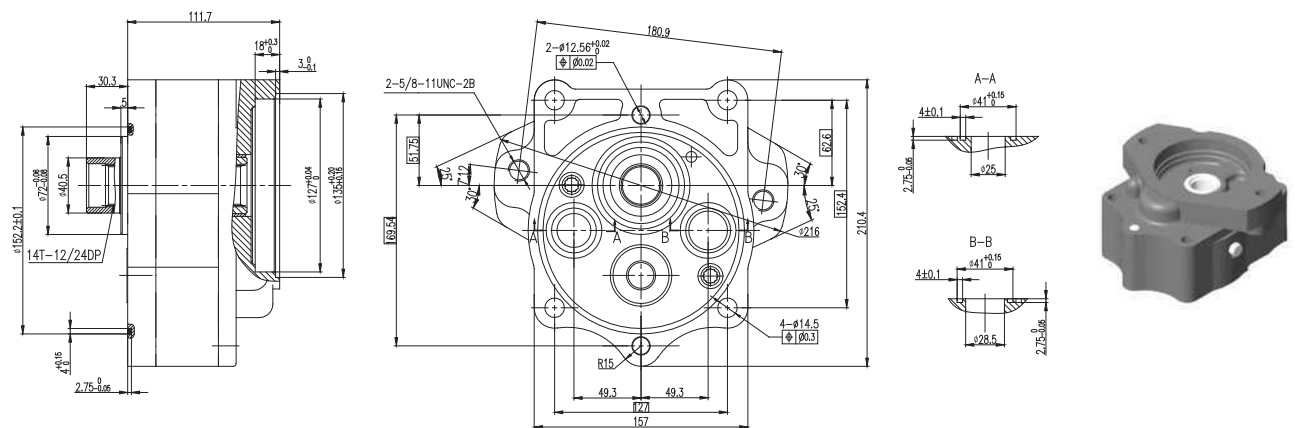

3P6816/3P6814/3P0380/2P9239 Gear Pumps

3P6816 / 3P6814 Dimensions

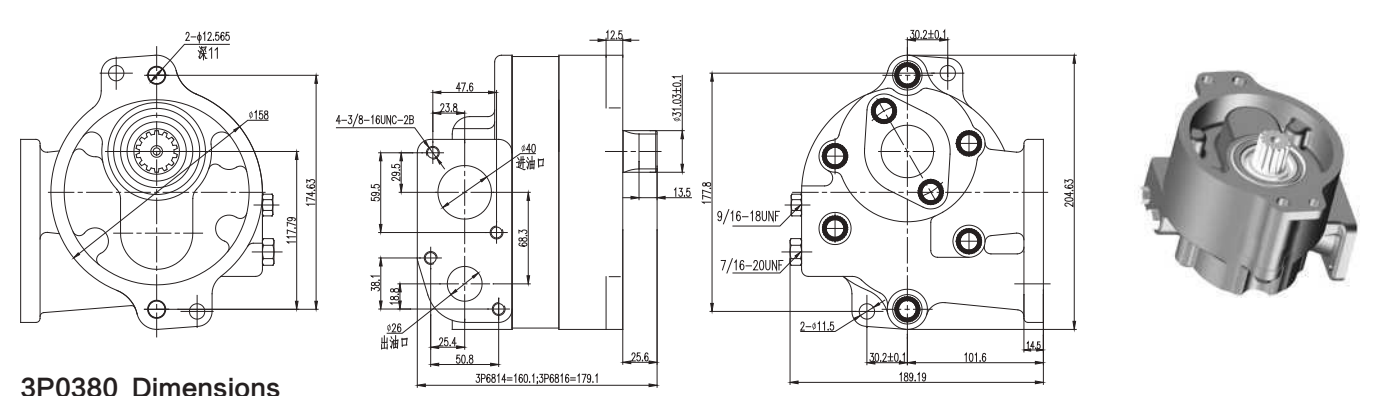

3P0380 Dimensions

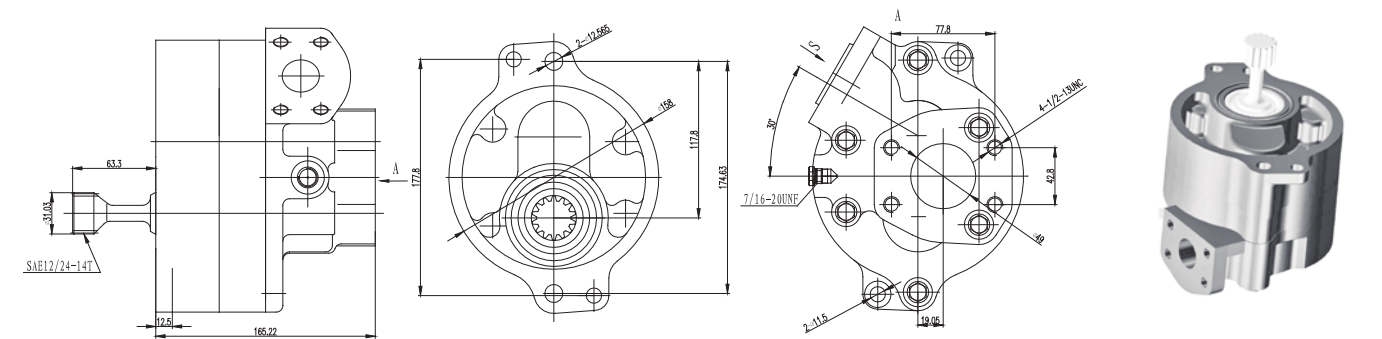

2P9239 Dimensions

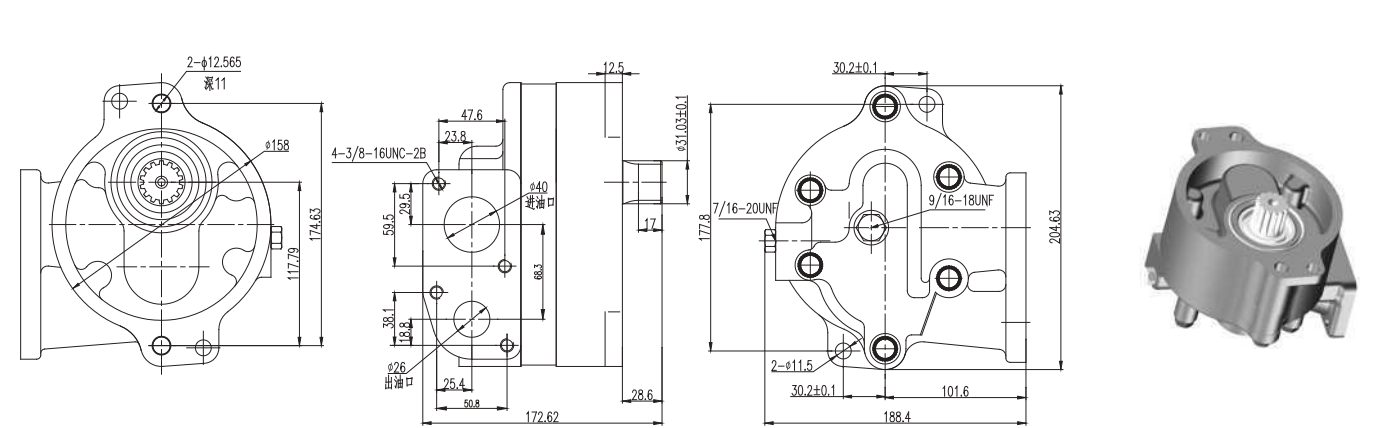

3G4768/5M7864/5H1719 Gear Pumps

3G4768 Dimensions

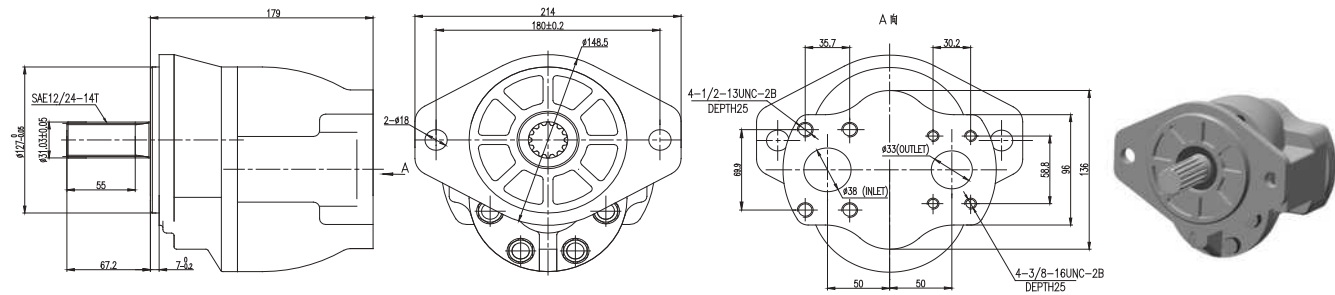

5M7864 Dimensions

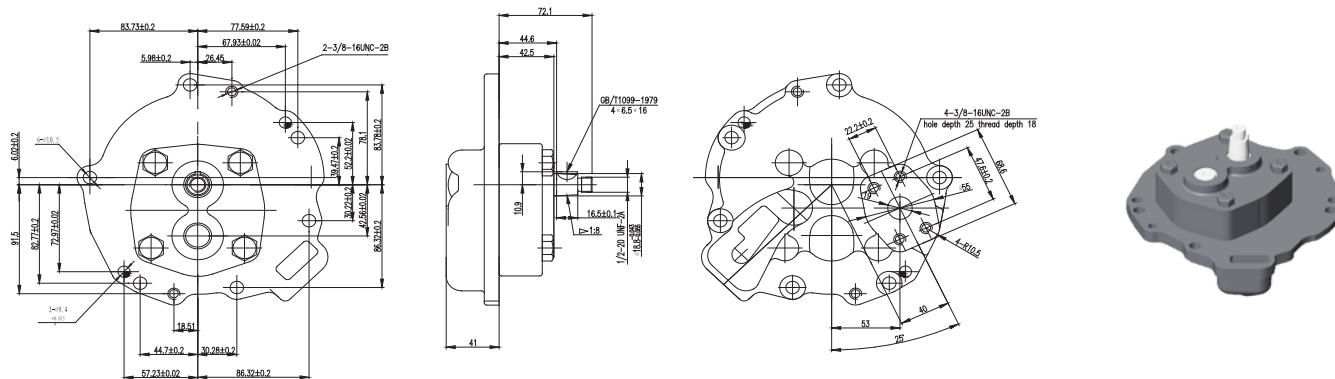

5H1719 Dimensions

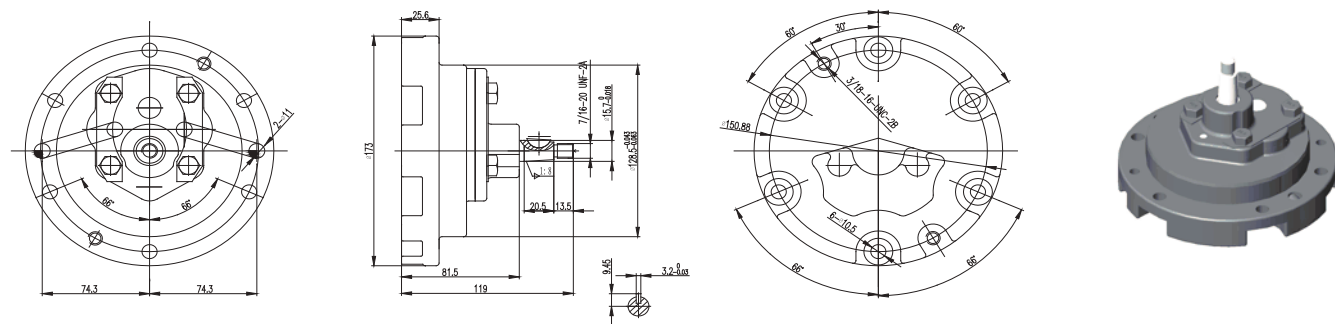

3N2078/4W5479/4W2448 Gear Pumps

3N2078 Dimensions

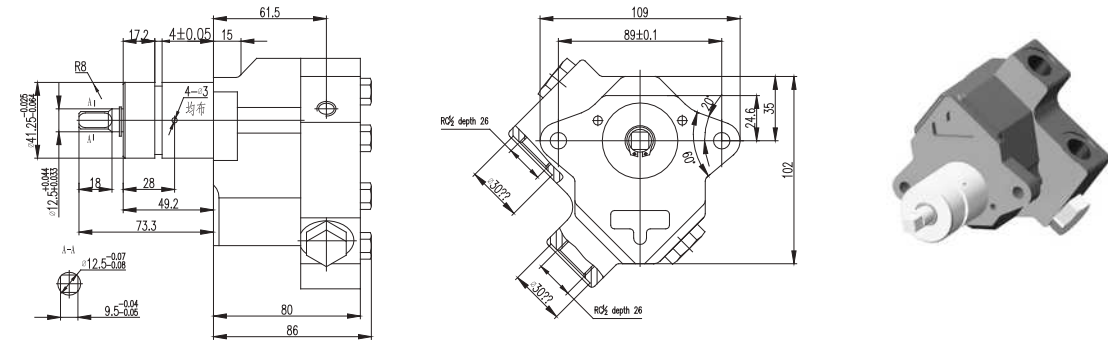

4W5479 Dimensions

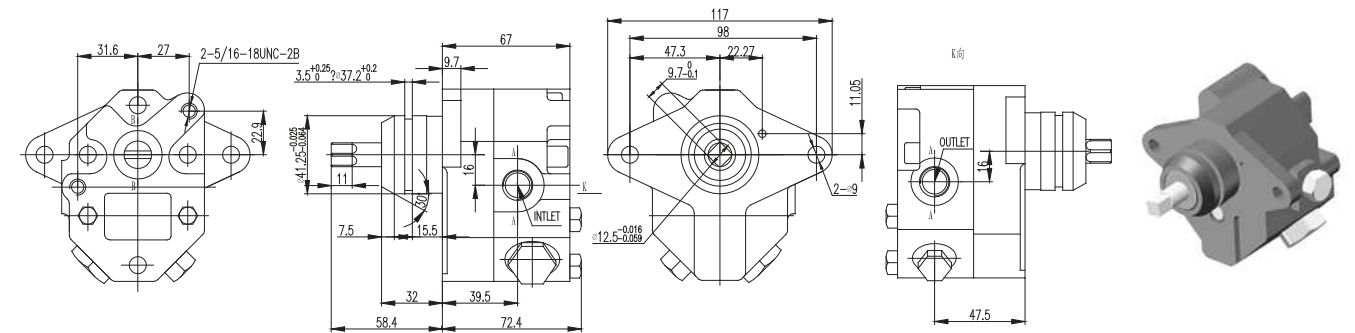

4W2448 Dimensions

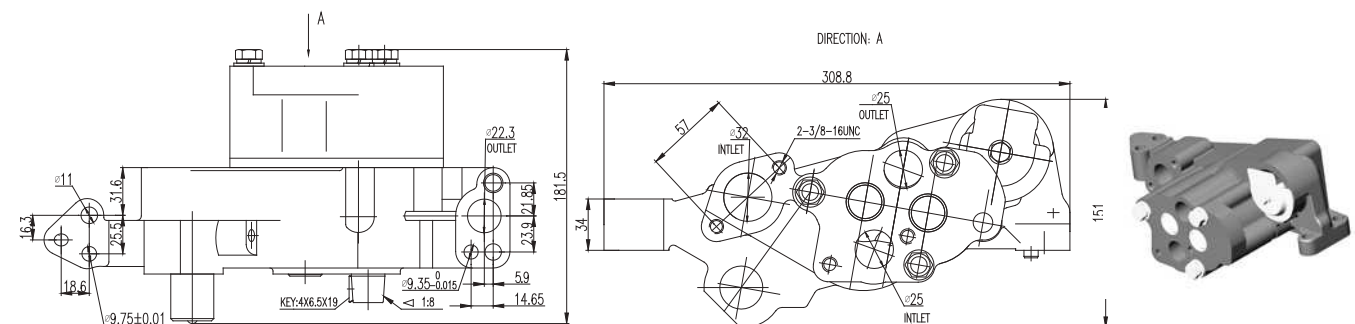

9P9610/1233472/9U9535 Gear Pumps

9P9610 Dimensions

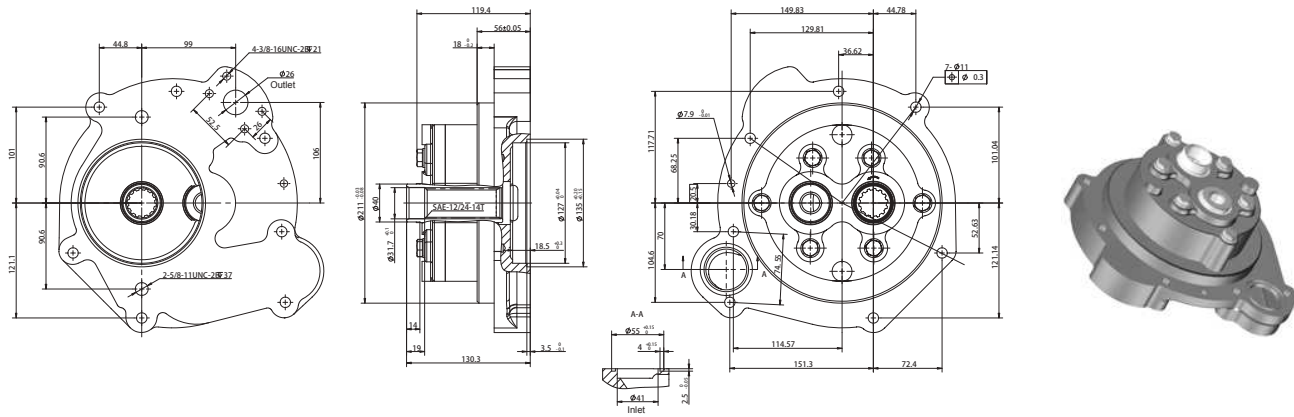

1233472 Dimensions

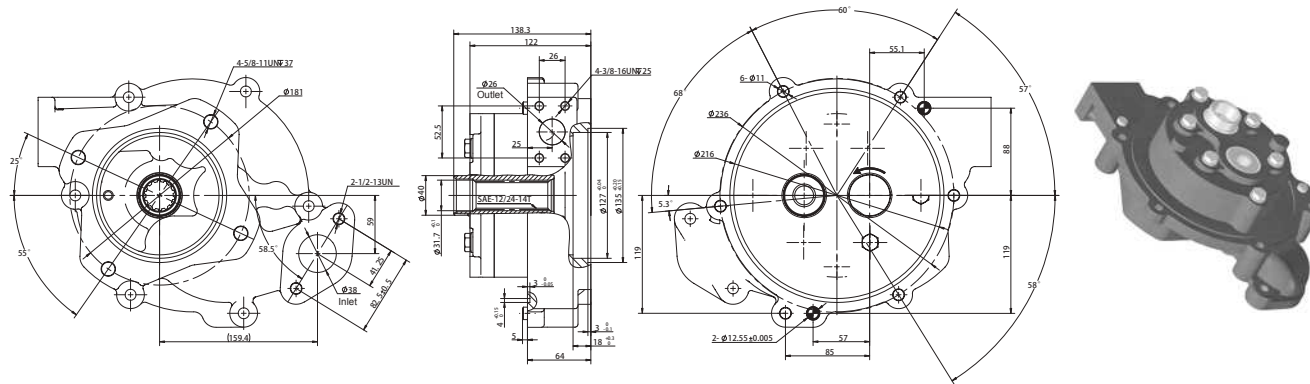

9U9535 Dimensions

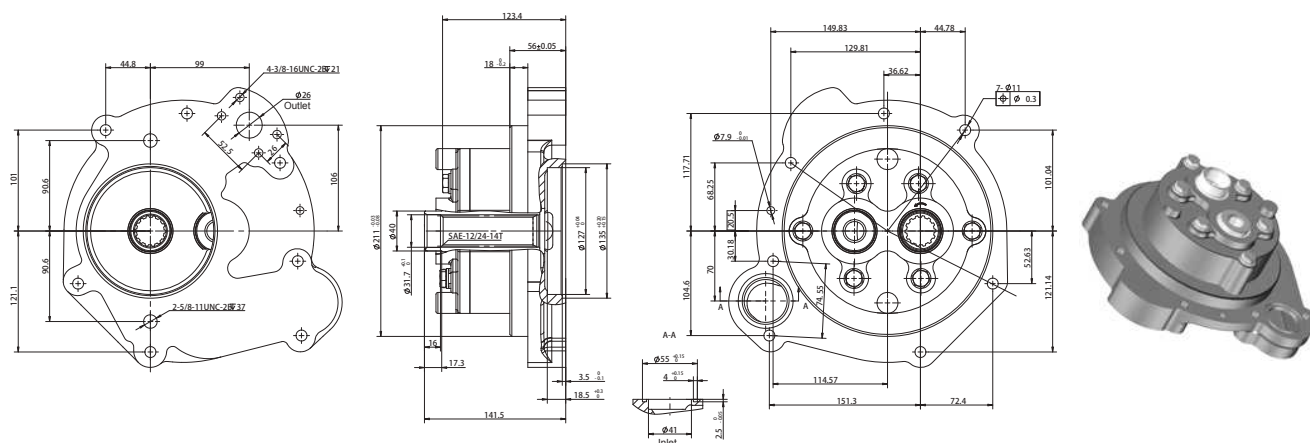

7G4856/8E1217/119294/1226658 Gear Pumps

7G4856 Dimensions

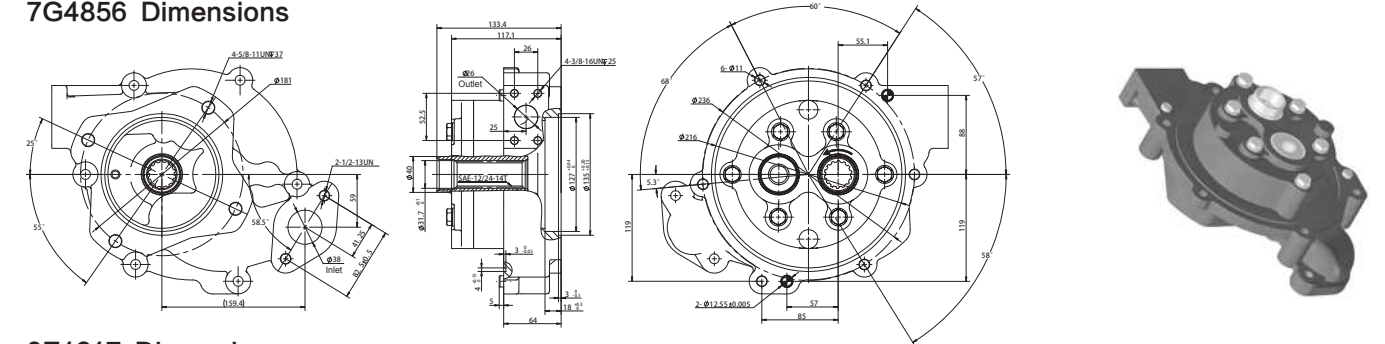

8E1217 Dimensions

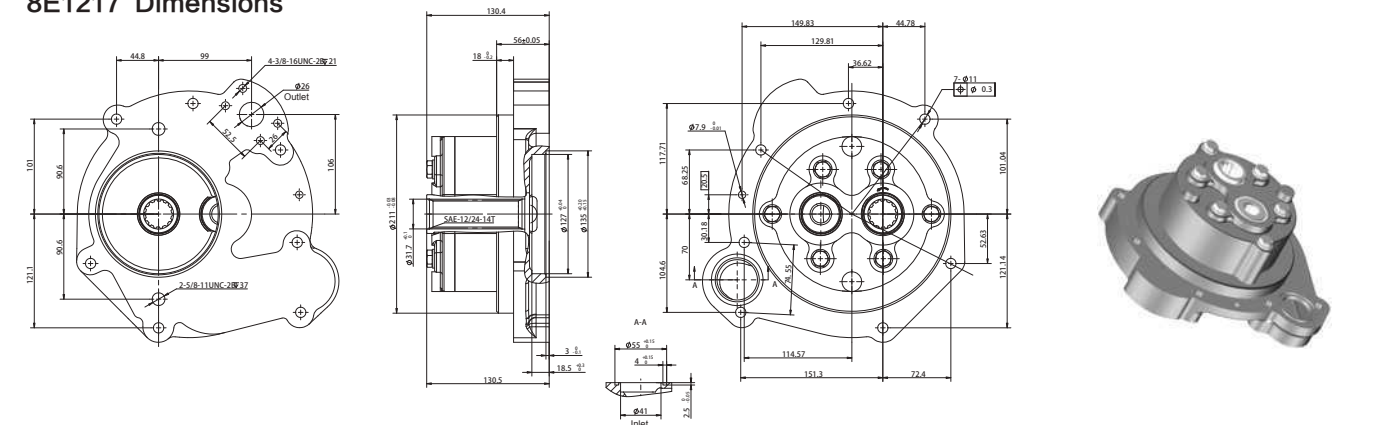

119294 Dimensions

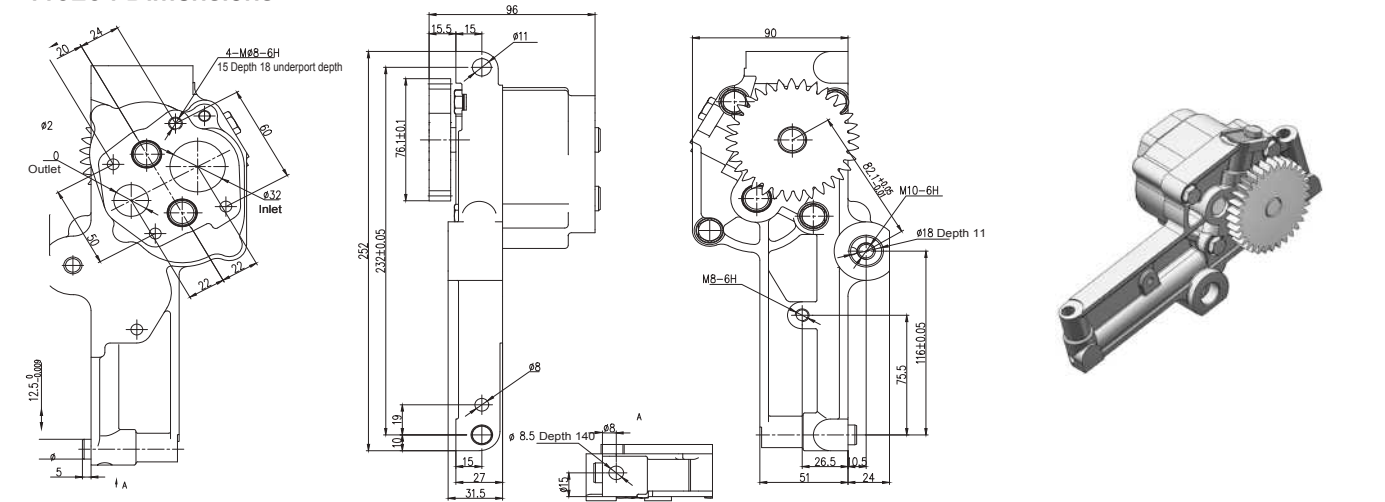

1226658 Dimensions

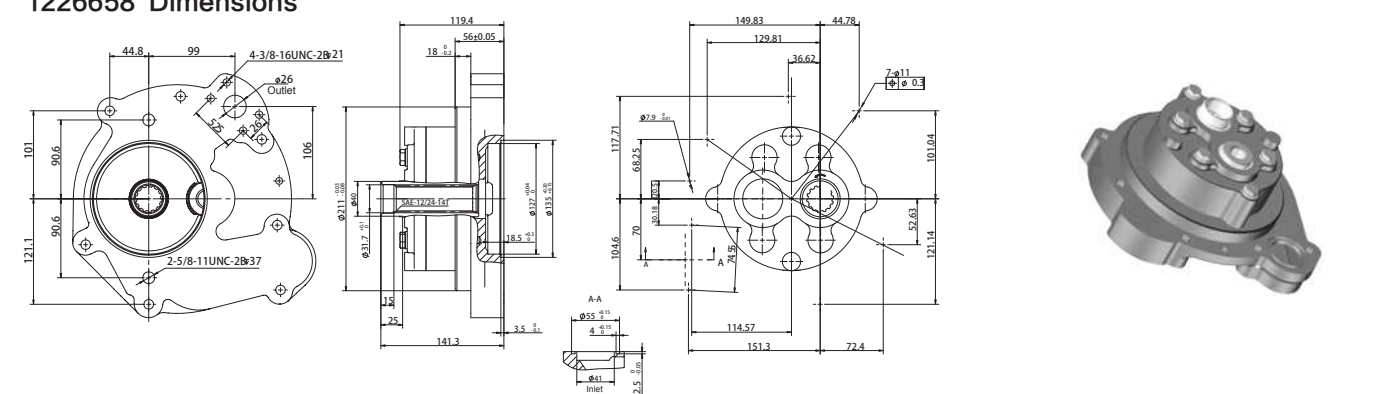

Inlet/outlet combination

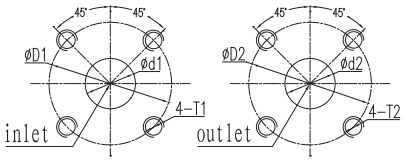
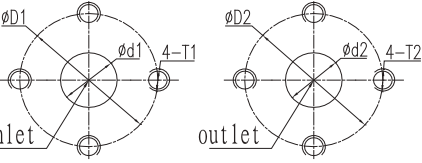
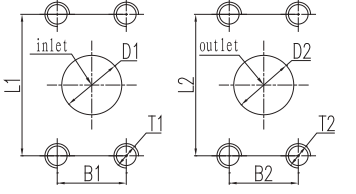
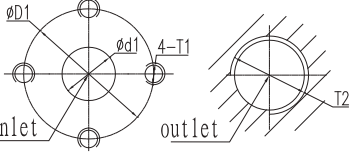
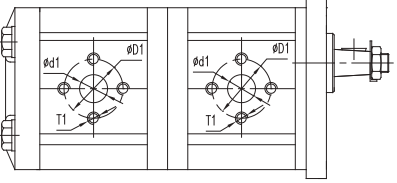
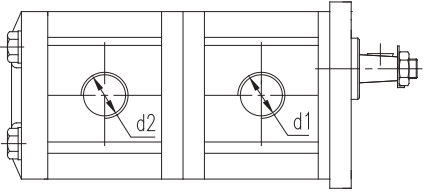
Inlet/Outlet	Ports Type
	Inlet/outlet thread combination
	X Shape Inlet/outlet flange combination
	+ Shape Inlet/outlet flange combination
	# Shape Inlet/outlet flange combination
	Inlet/outlet thread and flange combination
	Double pump inlet/outlet combination
	Double pump inlet/outlet combination

Oblate Type Shafts

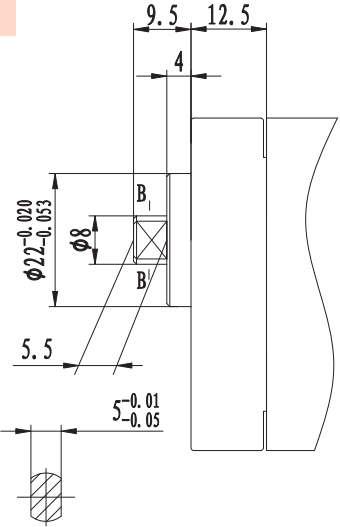
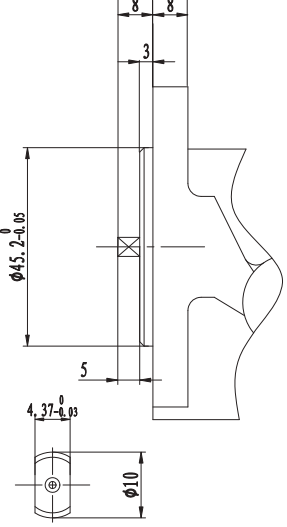
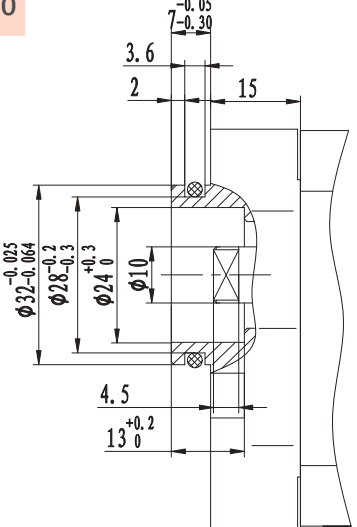
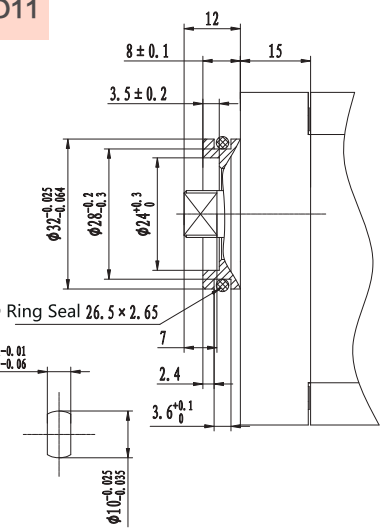
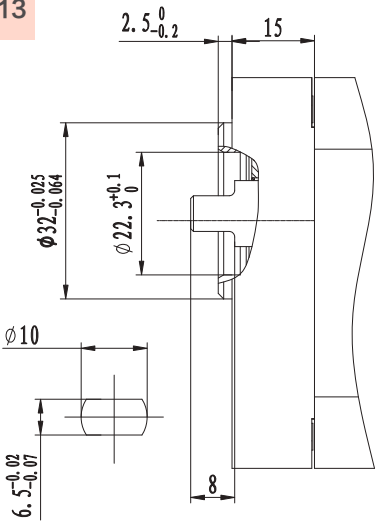
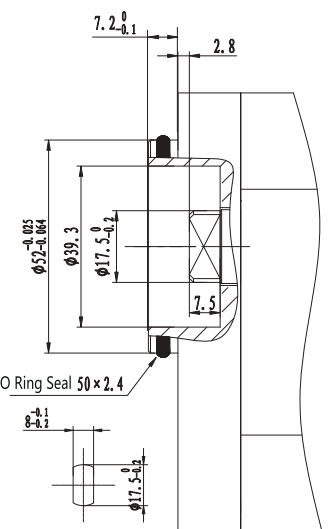
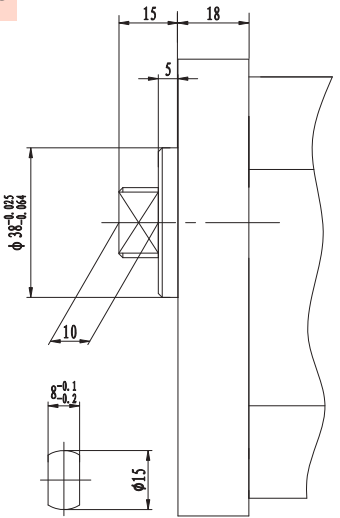
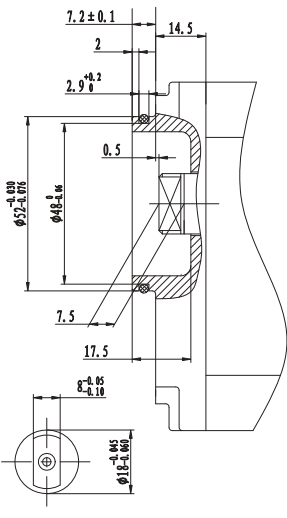
<p>O3</p> 	<p>O9</p> 	<p>O10</p> 
<p>O11</p> 	<p>O13</p> 	<p>O14</p> 
<p>O20</p> 	<p>O27</p> 	

Flat Keyed Type Shafts

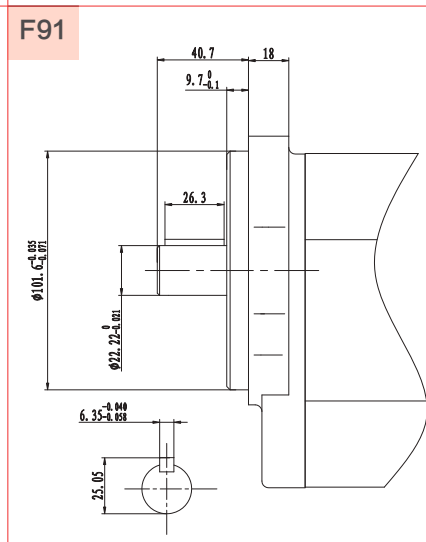
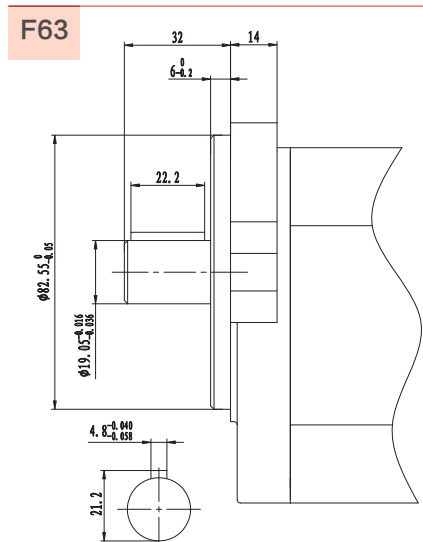
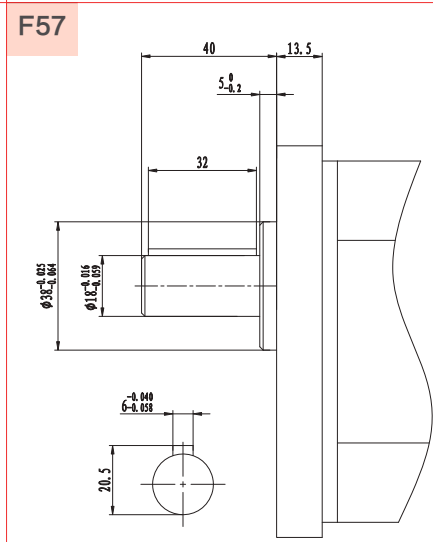
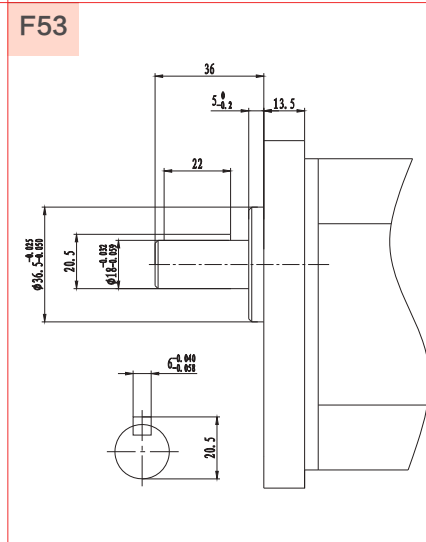
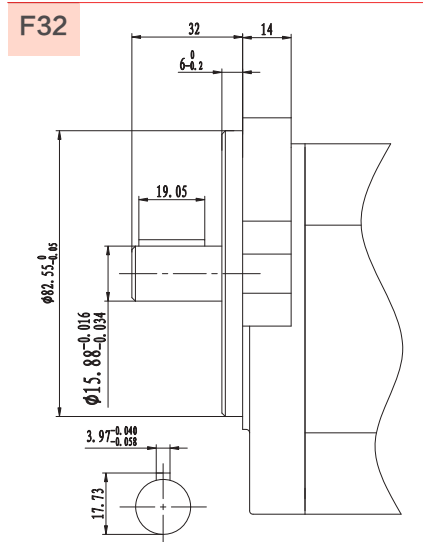
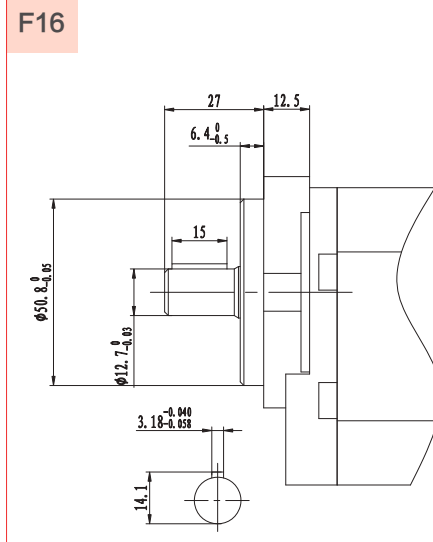
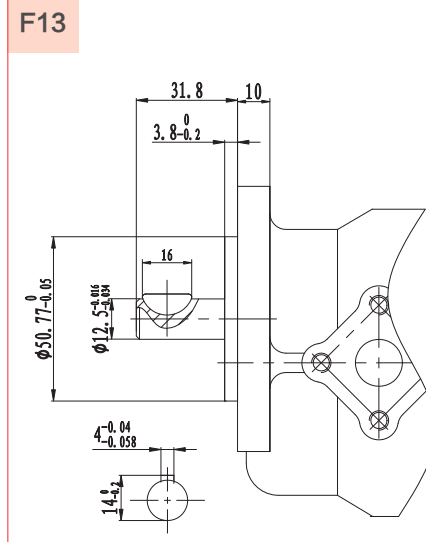
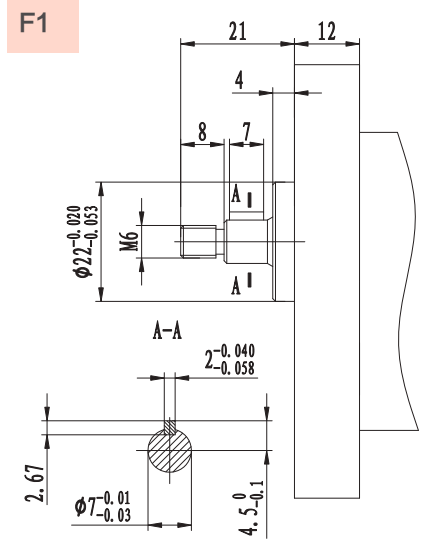

Taper Key Type Shafts

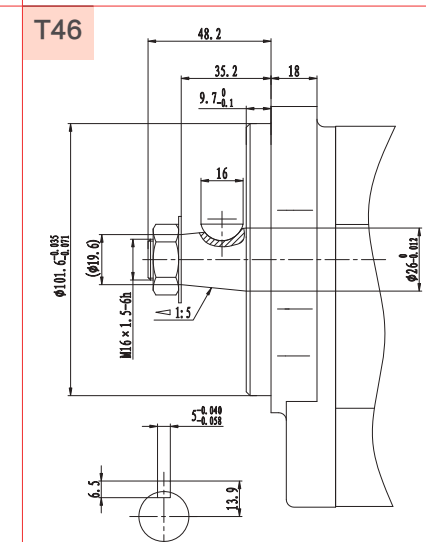
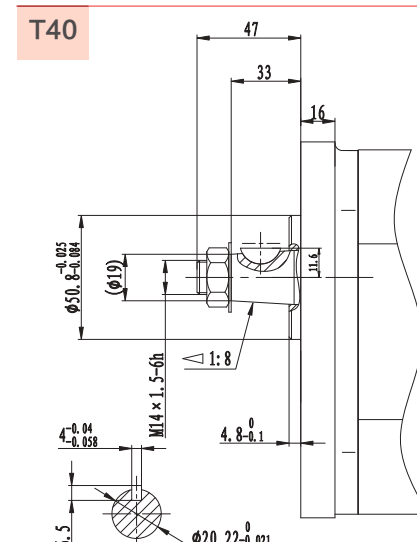
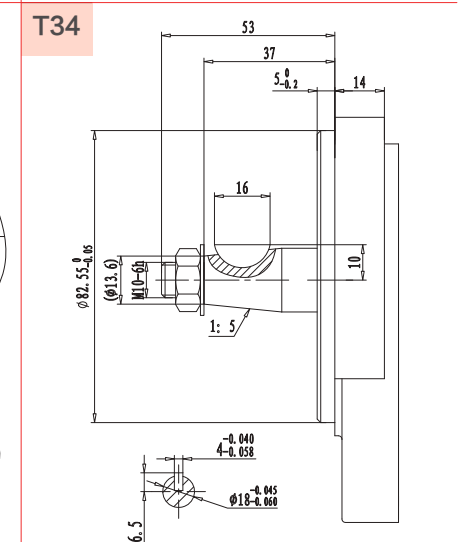
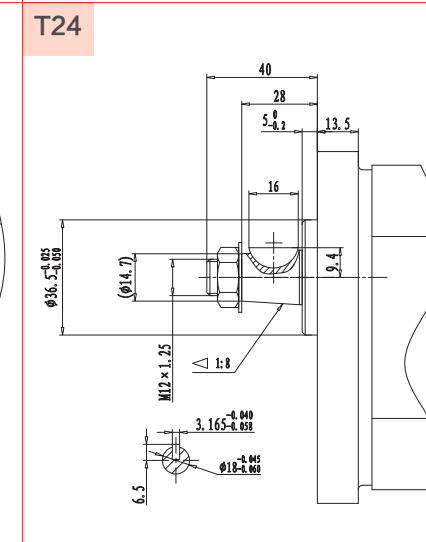
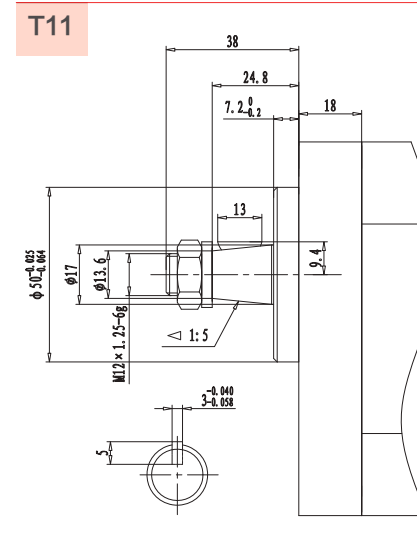
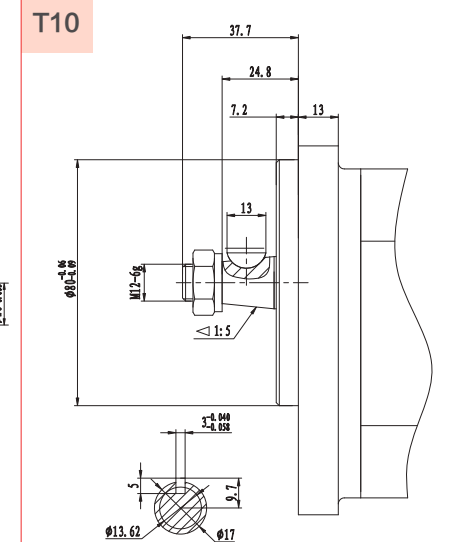
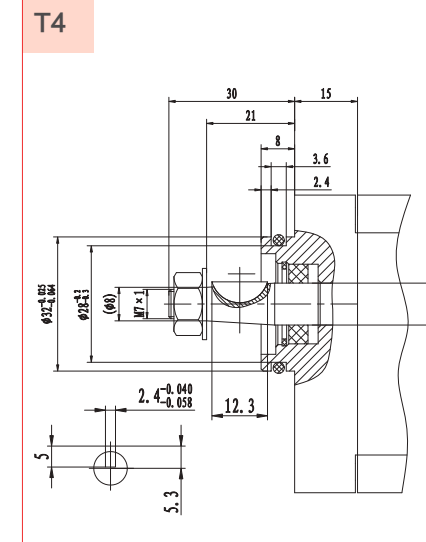
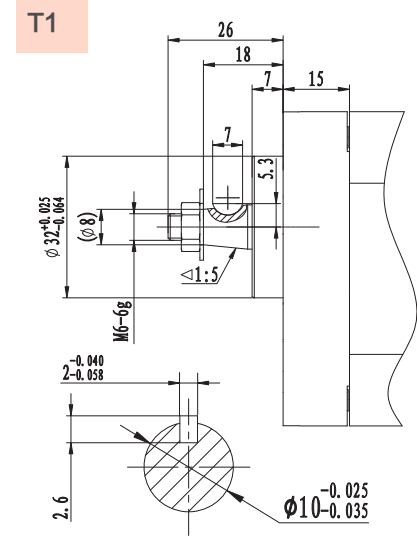

SAE and Metric Involute Spline Type Shafts

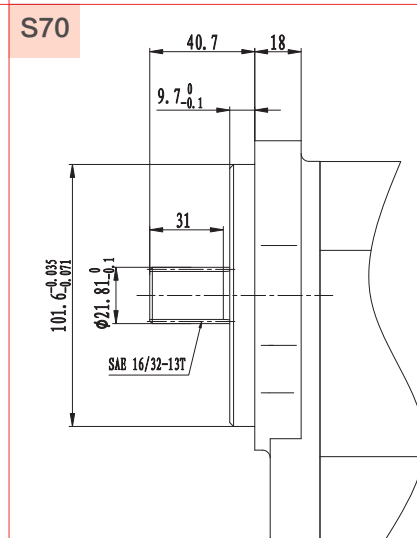
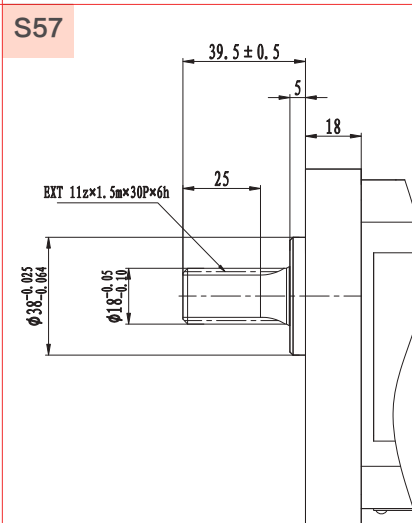
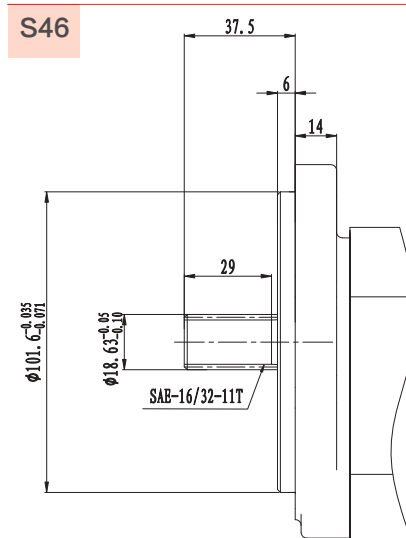
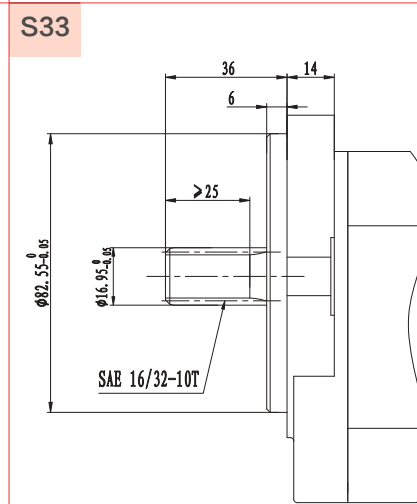
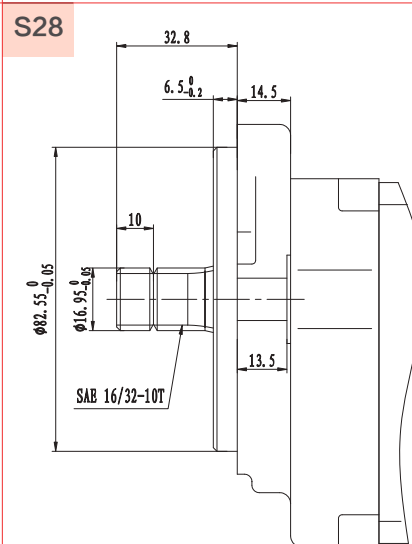
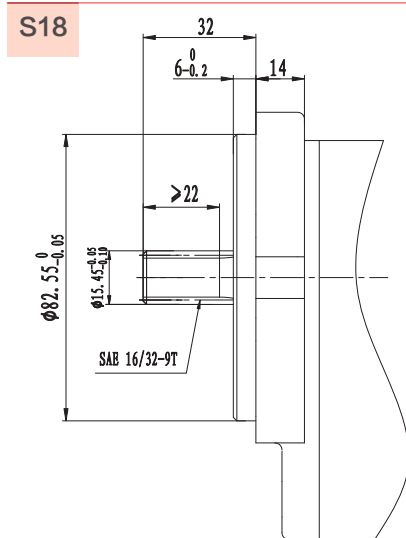
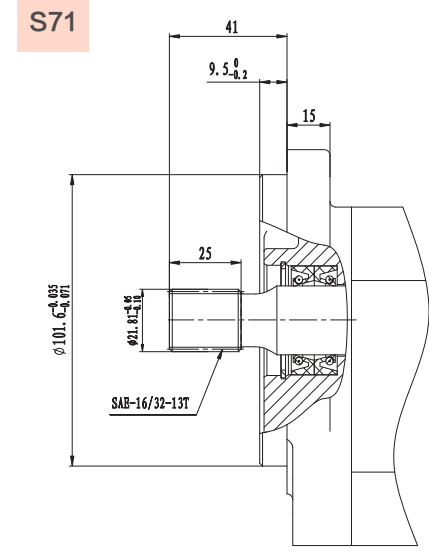
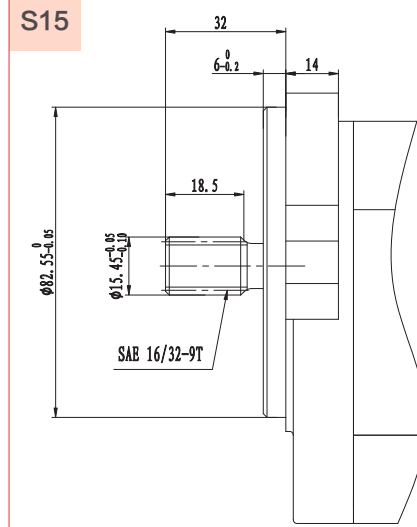
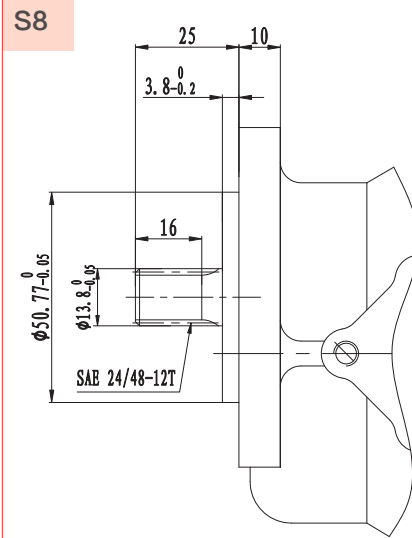
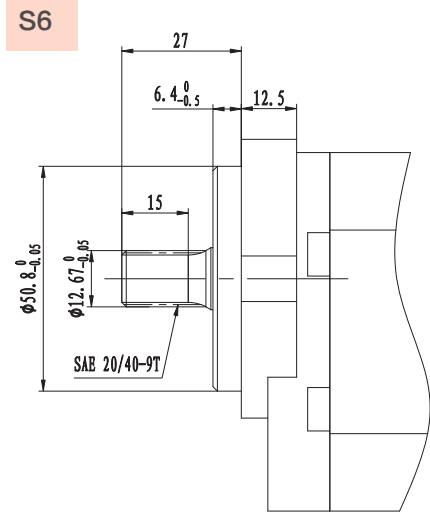

DIN Spline Type Shafts

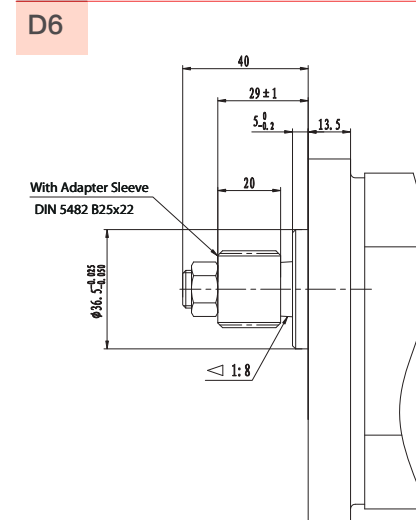
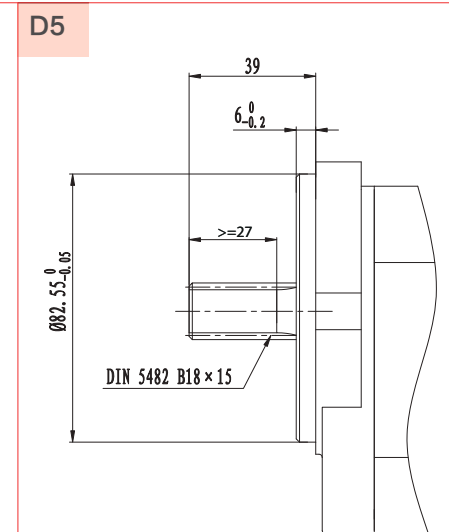
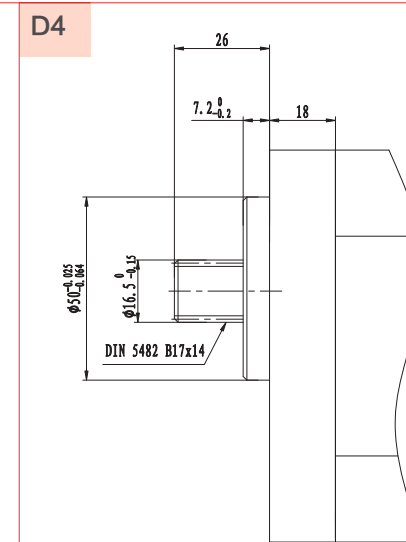
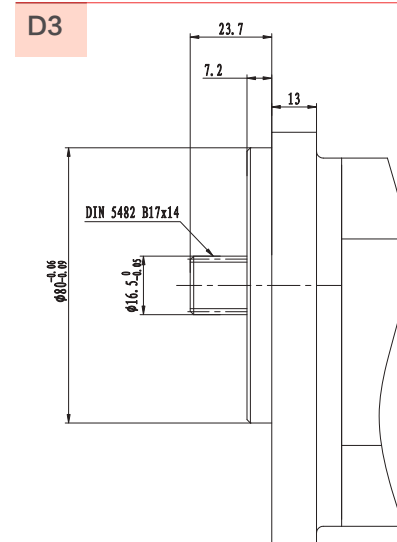

Diamond Type Front Covers

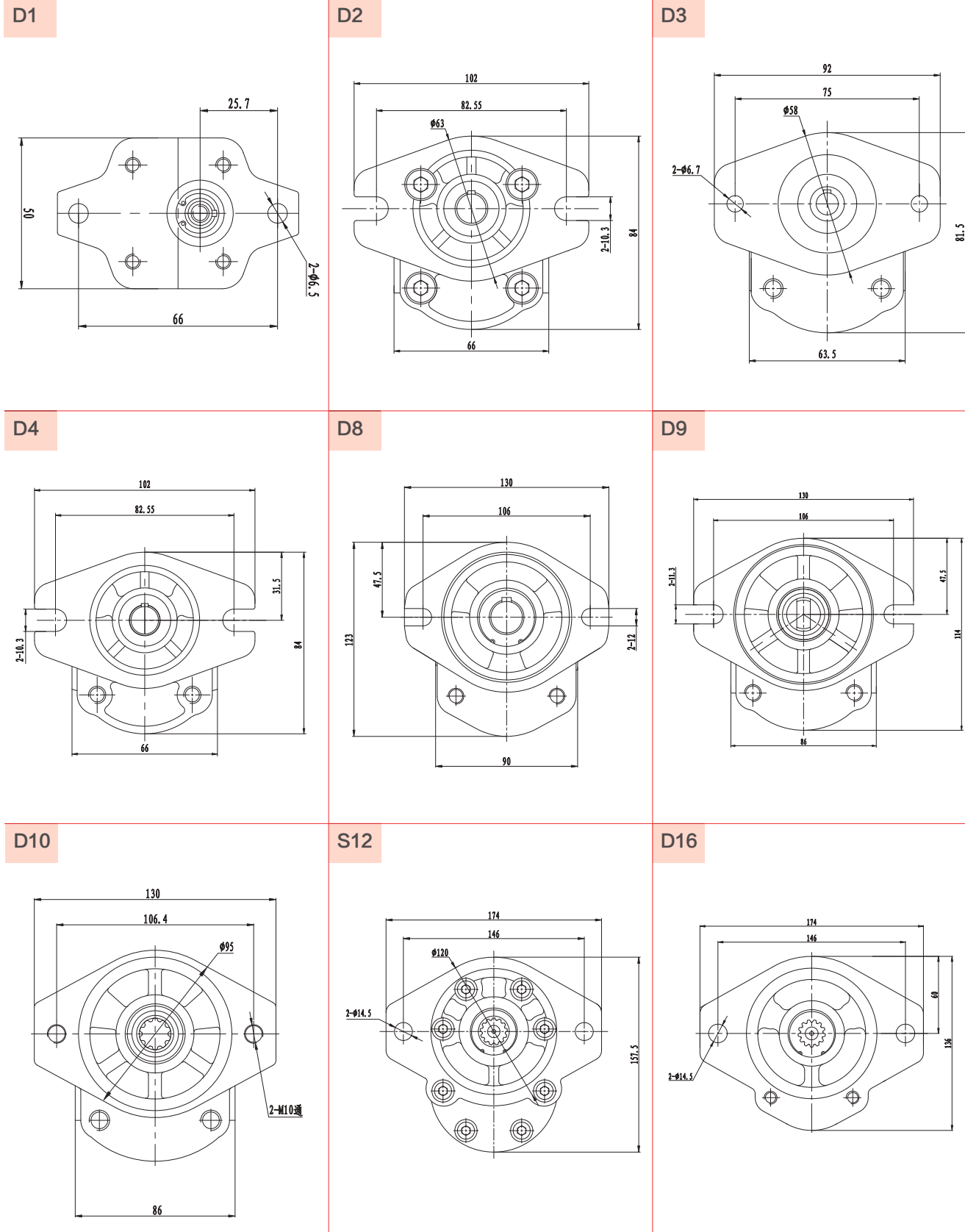

Oval Type Front Covers

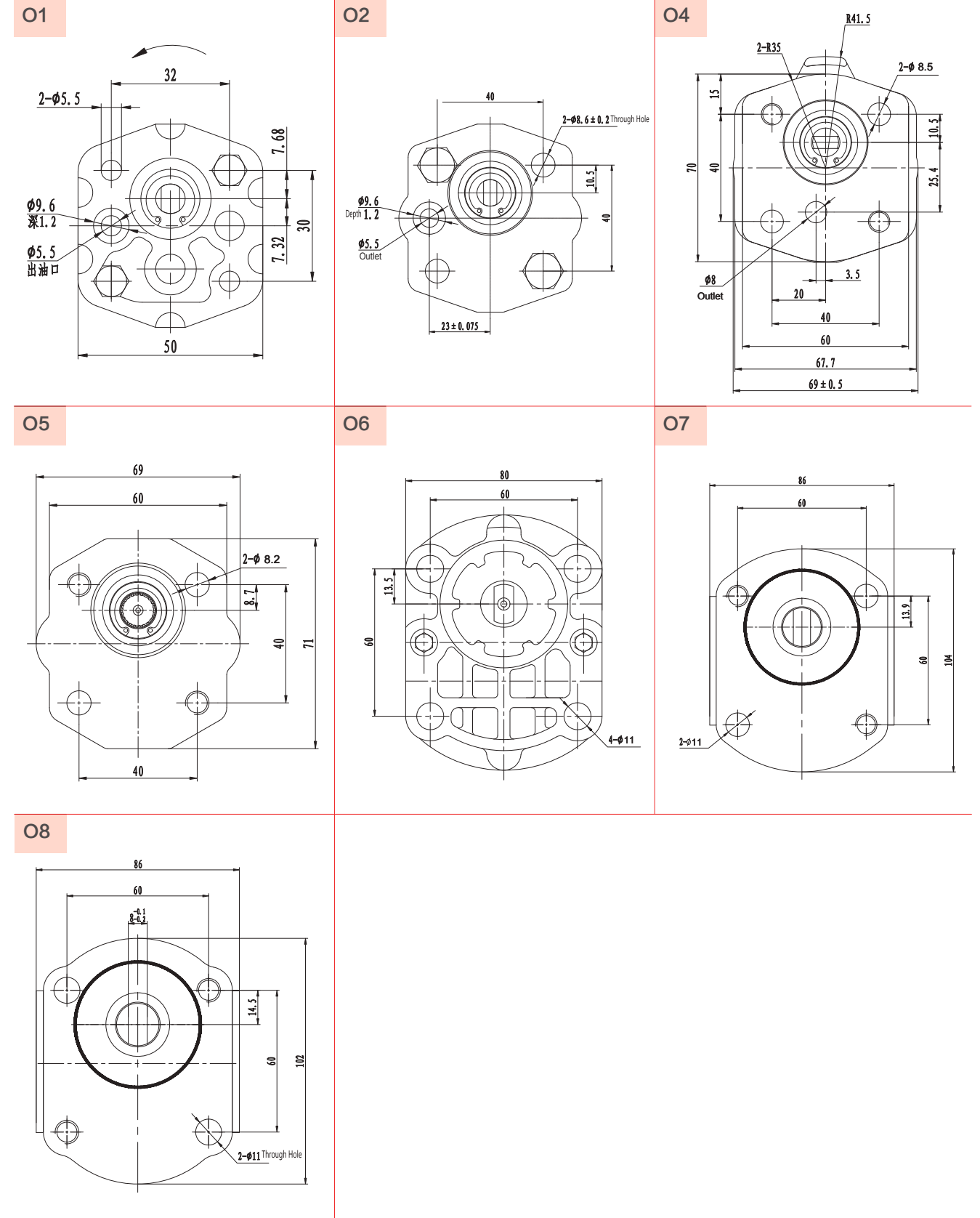

Square Type Front Covers

S1

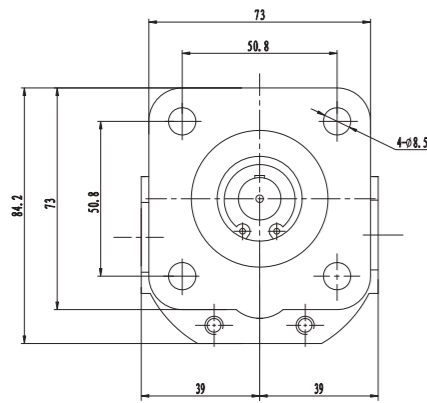

S2

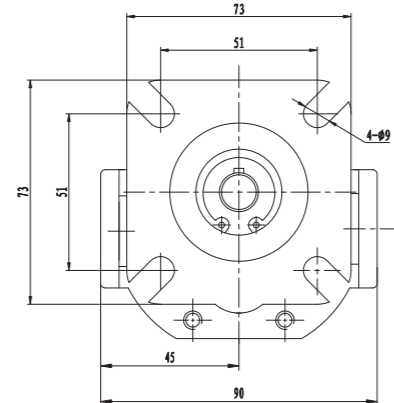

S3

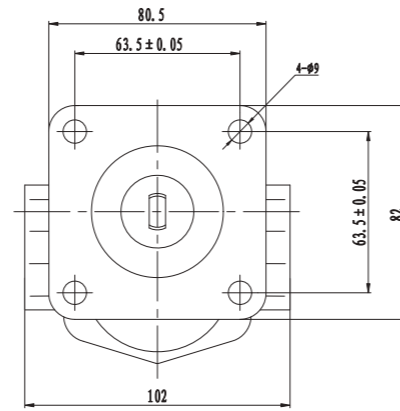

S5

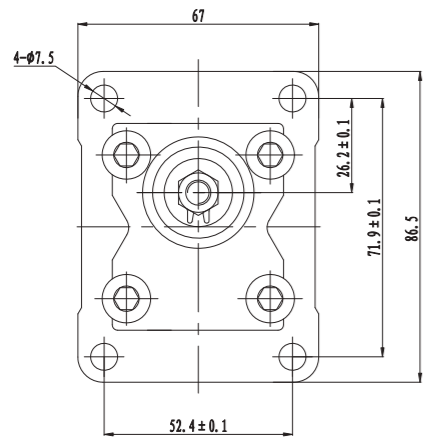

S6

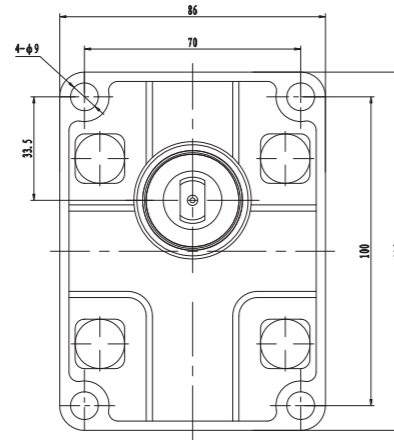

S7

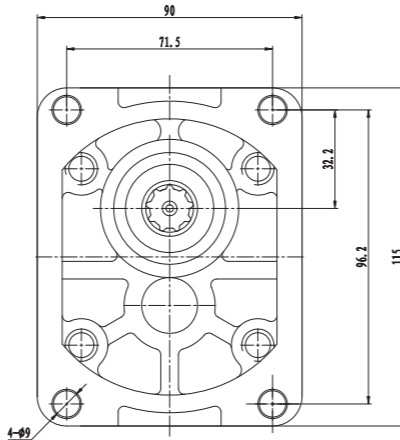

S8

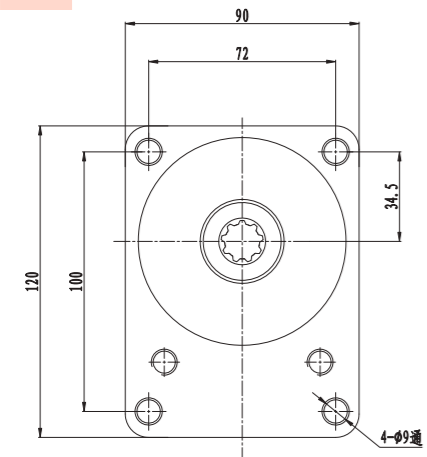

S10

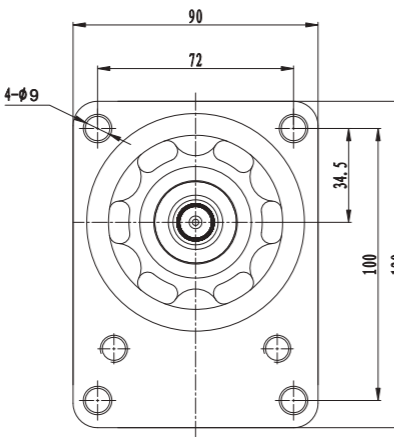

Square Type Front Covers

S11

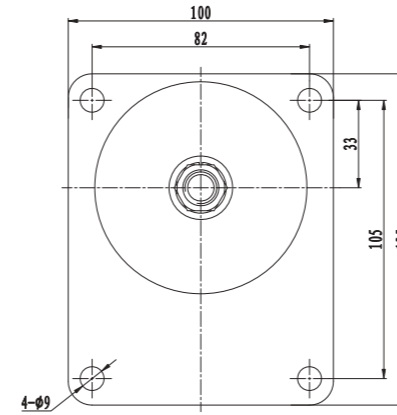

S14

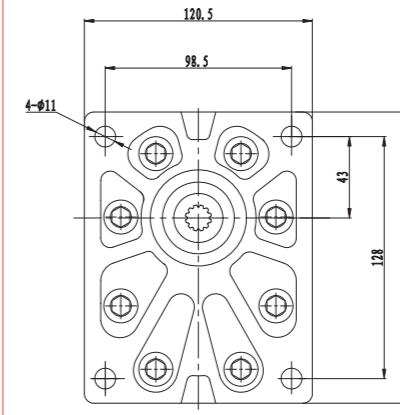

S18

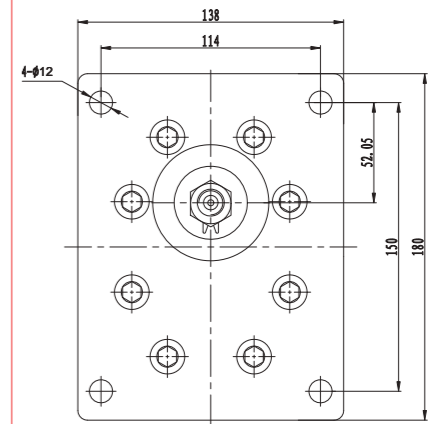

S19

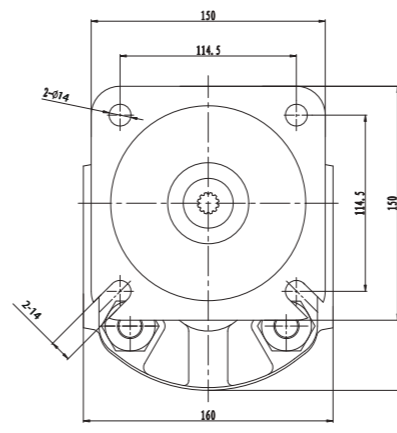

Special Type Front Covers

SP1

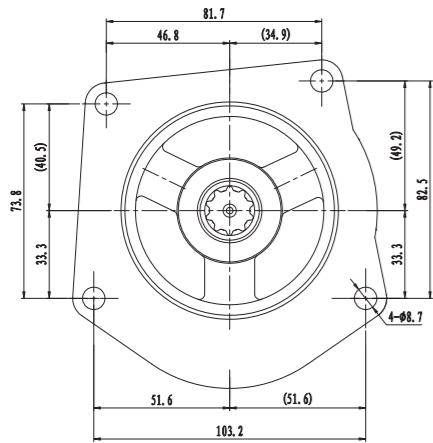

SP2

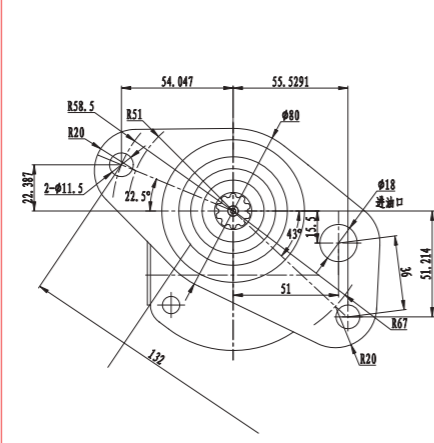

SP4

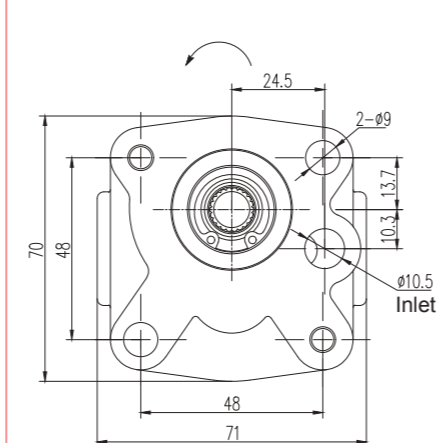

SP5

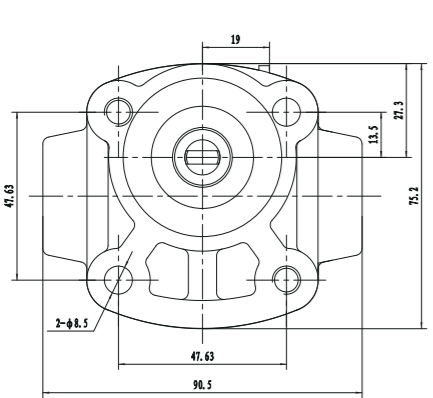

SP6

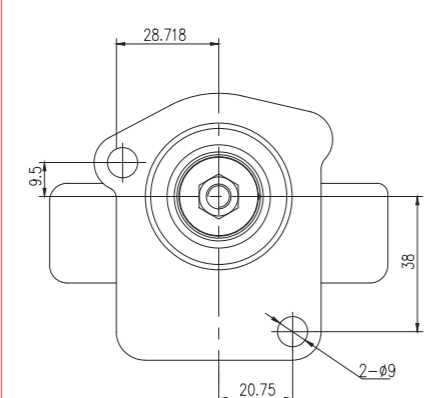

SP7

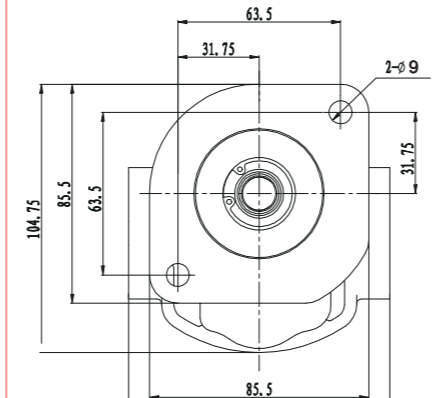

SP8

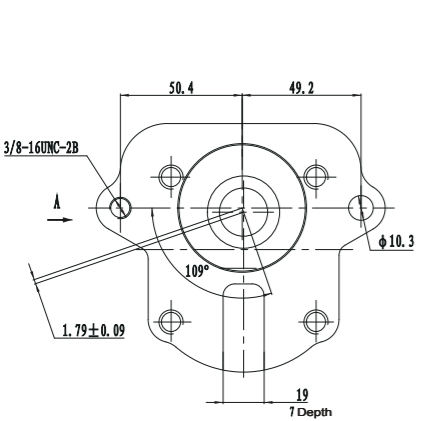

SP9

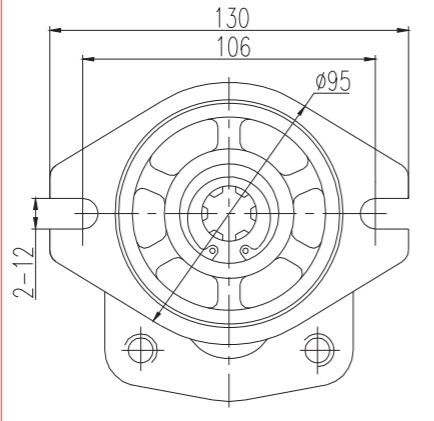

SP10

