

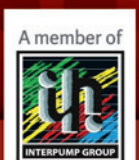

**Pompe e motori ad ingranaggi**  
***Gear pumps & motors***

**CATALOGO TECNICO - TECHNICAL CATALOGUE**



#### **Ulteriori informazioni**

Il catalogo mostra il prodotto nelle configurazioni più comuni.  
Per informazioni più dettagliate o richieste particolari contattare il Servizio Commerciale.

#### **ATTENZIONE!**

Specifiche tecniche, disegni e descrizioni riportati nel presente catalogo, sono riferiti al prodotto standard al momento dell'entrata in stampa.

Walvoil, orientata verso il continuo miglioramento del prodotto, si riserva il diritto di apportare modifiche in ogni momento e senza l'obbligo di alcun preavviso.

**WALVOIL NON RISPONDE DEI DANNI CHE DOVESSERO ESSERE ARRECATI A PERSONE O COSE DERIVANTI DA UN USO IMPROPRIO DEL PRODOTTO.**

#### **Additional information**

*This catalogue shows the product in the most standard configurations.  
Please contact our Sales Dpt. for more detailed information or special requests.*

#### **WARNING!**

*All specifications of this catalogue refer to the standard product at this date.  
Walvoil, oriented to a continuous improvement, reserves the right to discontinue, modify or revise the specifications, without notice.*

**WALVOIL IS NOT RESPONSIBLE FOR ANY DAMAGE CAUSED BY AN INCORRECT USE OF THE PRODUCT.**

6<sup>th</sup> Edition November 2018

# POMPE & MOTORI AD INGRANAGGI GEAR PUMPS & MOTORS

edizione - edition: D1WGEM01IE

## INDICE GENERALE GENERAL INDEX

### **POMPE AD INGRANAGGI • GEAR PUMPS 2**

Gamma Prodotto - <i>Product Range</i>	3
Informazioni tecniche - <i>Technical Information</i>	7
Prestazioni - <i>Performances</i>	12
Gruppo - <i>Group 1SP</i>	18
Gruppo - <i>Group 2SP</i>	34
Gruppo - <i>Group 3GP</i>	68

### **POMPE MULTIPLE AD INGRANAGGI • MULTIPLE GEAR PUMPS 79**

Informazioni tecniche - <i>Technical information</i>	80
Combinazioni - <i>Combinations</i>	81

### **MOTORI AD INGRANAGGI • GEAR MOTORS 99**

Gamma Prodotto - <i>Product Range</i>	100
Informazioni tecniche - <i>Technical Information</i>	103
Prestazioni - <i>Performances</i>	107
Gruppo - <i>Group 1SM</i>	113
Gruppo - <i>Group 2SM</i>	124
Gruppo - <i>Group 3GM</i>	156

### **ACCESSORI • ACCESSORIES 169**

Supporti - <i>Supports</i>	169
Raccordi - <i>Connectors</i>	173
Manicotti di trascinamento - <i>Males coupling</i>	175



**INTRODUZIONE • INTRODUCTION**

La pompa ad ingranaggi esterni è un componente ampiamente utilizzato per applicazioni oleodinamiche: la sua semplicità nella costruzione (rispetto ad altre tipologie di pompe più complesse come ad esempio pompe orbitali o a pistoni) unita alla grande versatilità, resistenza e lunga durata consentono una manutenzione ridotta e costi d'acquisto più contenuti.

Tali pompe possono sia lavorare in condizioni gravose con l'erogazione di elevate potenze idrauliche, sia in condizioni standard con una bassa emissione acustica ed elevati rendimenti idromeccanici e volumetrici grazie all'ottima bilanciatura.

La gamma Galtech grazie un costante lavoro di ricerca unito all'esperienza pluriennale, alla meticolosa scelta dei materiali e alla costante cura nel processo non solo di produzione, ma anche nei test di validazione si è ampliata mantenendo elevati standard qualitativi.

Le pompe ad ingranaggi esterni sono costituite da 3 gruppi: 1SP, 2SP (a 12 denti) e 3GP (a 10 denti) con ben 32 cilindrate da 0.89 a 77 cc/giro adatte alle più variate applicazioni sia industriali che nel campo del mobile con elevati rapporti potenza/peso e potenza/dimensioni.

Si possono raggiungere pressioni elevate fino a 300 bar e velocità massime di rotazione di 4000 giri/min.

Le pompe Galtech possono essere assemblate con totale intercambiabilità sia con flange standard (europea, tedesca, SAE) sia con tipologie speciali ed utilizzate con una vasta gamma di alberi come quelli conici, cilindrici scanalati e fresati con dente frontale.

Sono disponibili vari coperchi e flange in ghisa per ridurre la rumorosità e aumentare i limiti operativi. Inoltre è possibile montare coperchi con valvola limitatrice di pressione e valvole regolatrici di flusso.

Tutte le pompe sono predisposte per il montaggio in una o più ulteriori unità per la realizzazione di pompe multiple: diverse soluzioni di accoppiamento sono disponibili per privilegiare la compattezza costruttiva o una intercambiabilità più flessibile.

*The external gear pump is widely used for oleodynamic applications: its simplicity in construction (compared to other types of more complex pumps such as orbital or axial piston pumps) coupled with great versatility, strength and durability allow reduced maintenance and lower purchasing costs.*

*These pumps can work both under harsh conditions with high hydraulic power supply, both in standard conditions with a low noise level and high hydromechanical efficiency and excellent volumetric balancing.*

*The Galtech range thanks to a constant research combined with years of experience, meticulous choice of materials and constant care of the process not only in production, but also in the validation tests, has expanded while maintaining high quality standards.*

*The external gear pumps consist of 3 groups: 1SP, 2SP (12 teeth) and 3GP (10 teeth) with 32 displacements from 0.89 to 77 cc/rev suited to various applications in the field of mobile with high industrial power-to-weight and power/size ratios.*

*You can reach high pressures up to 300 bar and maximum speeds of rotation of 4000 rpm.*

*Galtech pumps can be assembled with complete interchangeability both with standard flanges (European, German, SAE) and with special flanges used with a variety of shafts as those the cylindrical, conical grooved and milled ones with front tooth.*

*Several cast iron covers and flanges are available to reduce noise and to increase the operating limits. Covers with pressure relief valve and flow control valves can be assembled as well.*

*All the pumps are arranged for the mounting into one or more additional units to complete multiple pumps: different coupling solutions are available to privilege the construction compactness or a more flexible interchangeability.*

**POMPE AD INGRANAGGI GAMMA PRODOTTO**  
**GEAR PUMPS PRODUCT RANGE**

Le cilindrata disponibili sono evidenziate nel seguente diagramma (cm<sup>3</sup>/giro):  
 The available displacements are shown below (cm<sup>3</sup>/rev):

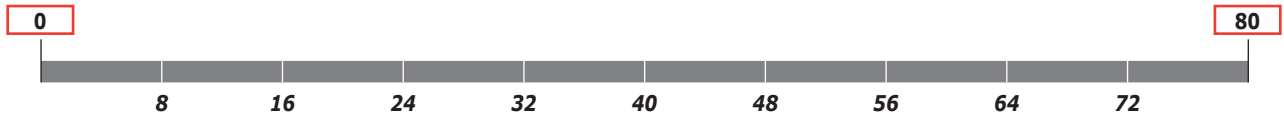

0.89  
**1SP**  
 9.78

4.0  
**2SP**  
 31.5

19.3  
**3GP**  
 77.2



**POMPE AD INGRANAGGI** **GAMMA PRODOTTO**  
**GEAR PUMPS** **PRODUCT RANGE**

GRUPPO GROUP <b>1SP</b>	CILINDRATA DISPLACEMENT		VELOCITÀ MAX MAX SPEED	PORTATA MAX MAX FLOW		VELOCITÀ MIN MIN SPEED
	cm <sup>3</sup> /giro	in <sup>3</sup> /rev	giri/min - rpm	l/min	Gal/min	giri/min - rpm
<b>1SP 009</b>	0.89	0.05	6000	5.3	1.40	600
<b>1SP 012</b>	1.18	0.07	6000	7.1	1.88	600
<b>1SP 016</b>	1.6	0.10	6000	9.6	2.54	400
<b>1SP 020</b>	2.0	0.12	5500	11	2.91	400
<b>1SP 025</b>	2.5	0.15	5000	12.5	3.30	400
<b>1SP 032</b>	3.2	0.20	4500	14.4	3.80	400
<b>1SP 037</b>	3.7	0.23	4000	14.8	3.91	400
<b>1SP 042</b>	4.2	0.26	3500	14.7	3.88	400
<b>1SP 050</b>	5.0	0.31	3000	15	3.96	400
<b>1SP 063</b>	6.3	0.38	2700	17	4.49	400
<b>1SP 078</b>	7.76	0.47	2500	19.4	5.13	400
<b>1SP 098</b>	9.78	0.60	2000	19.6	5.18	400

## FLANGE - FLANGES

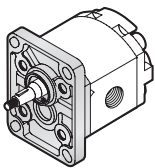
**EUR**

pagina/page 18

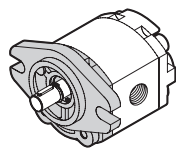
**SAEAA**

pagina/page 19

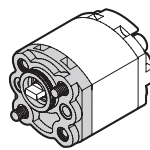
**MC32**

pagina/page 20

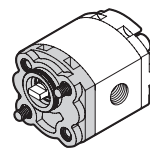
**E32BX - E32BC**

pagina/page 21

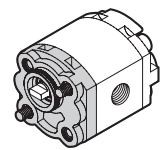
**E32CX - E32CC**

pagina/page 23

**POMPE AD INGRANAGGI GAMMA PRODOTTO**  
**GEAR PUMPS PRODUCT RANGE**

GRUPPO GROUP 2SP	CILINDRATA DISPLACEMENT		VELOCITÀ MAX MAX SPEED	PORTATA MAX MAX FLOW		VELOCITÀ MIN MIN SPEED
	cm <sup>3</sup> /giro	in <sup>3</sup> /rev	giri/min - rpm	l/min	Gal/min	giri/min - rpm
<b>2SP 040</b>	4	0.24	4000	16	4.23	500
<b>2SP 060</b>	6	0.37	4000	24	6.34	500
<b>2SP 080</b>	8.5	0.52	3500	29.7	7.85	500
<b>2SP 110</b>	11	0.67	3500	38.5	10.17	500
<b>2SP 140</b>	14	0.85	3500	49	12.95	500
<b>2SP 160</b>	16.5	1.01	3500	57.7	15.24	500
<b>2SP 190</b>	19.5	1.19	3300	64.3	16.99	500
<b>2SP 220</b>	22.5	1.37	2800	63	16.64	500
<b>2SP 260</b>	26	1.59	2500	65	17.17	500
<b>2SP 310</b>	31.5	1.92	2200	69	18.22	500

FLANGE - FLANGES

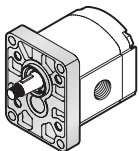
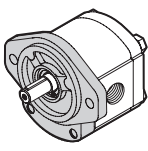
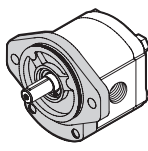
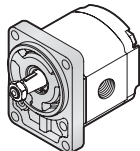
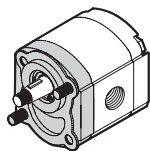
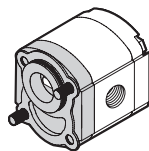
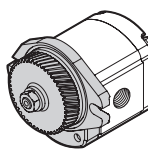
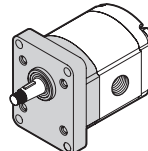
EUR	SAEA	SAEAOR	B80C	B50C	E52C	P400D	SUPEUR
							
pagina/page 34	pagina/page 36		pagina/page 38	pagina/page 39	pagina/page 40	pagina/page 41	pagina/page 42

FLANGE - FLANGES

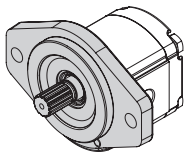
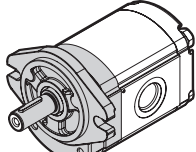
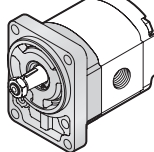
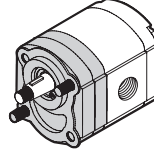
SAEB*	SUPSAE	SUPB80C	SUPB50CX
			
pagina/page 44	pagina/page 45	pagina/page 46	pagina/page 47

\* Contattare il servizio commerciale. / Available soon. Please contact our Sales Dpt.

**POMPE AD INGRANAGGI GAMMA PRODOTTO**  
**GEAR PUMPS PRODUCT RANGE**

GRUPPO GROUP <b>3GP</b>	CILINDRATA DISPLACEMENT		VELOCITÀ MAX MAX SPEED	PORTATA MAX MAX FLOW		VELOCITÀ MIN MIN SPEED
	cm <sup>3</sup> /giro	in <sup>3</sup> /rev	giri/min - rpm	l/min	Gal/min	giri/min - rpm
<b>3GP 190</b>	19.3	1.2	3500	67.6	17.84	600
<b>3GP 230</b>	23.0	1.4	3500	80.3	21.22	600
<b>3GP 300</b>	30.2	1.8	3300	99.7	26.33	600
<b>3GP 340</b>	33.8	2.1	3300	111.6	29.49	600
<b>3GP 370</b>	37.5	2.3	3300	123.6	32.66	600
<b>3GP 440</b>	44.6	2.7	3000	133.8	35.35	600
<b>3GP 530</b>	53.0	3.2	3000	159.1	42.04	600
<b>3GP 620</b>	62.7	3.8	2500	156.8	41.41	600
<b>3GP 700</b>	70.5	4.3	2500	176.3	46.58	600
<b>3GP 770</b>	77.2	4.7	2200	169.8	44.84	600

## FLANGE - FLANGES

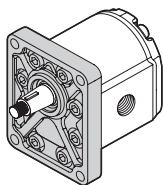
**EUR**

pagina/page 68

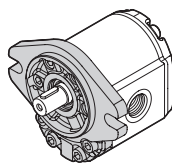
**SAEB\***

pagina/page 69

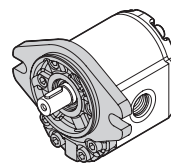
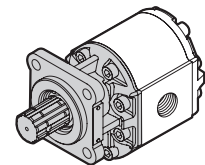
**SAEBOR**

**ZFC**

pagina/page 70

\* Contattare il servizio commerciale. / Available soon. Please contact our Sales Dpt.



## POMPE AD INGRANAGGI INFORMAZIONI TECNICHE GEAR PUMPS TECHNICAL INFORMATION

### FLUIDI IDRAULICI • HYDRAULIC FLUIDS

È consigliabile utilizzare oli idraulici di origine minerale con buone caratteristiche antischiuma, antiusura, antiossidanti, anticorrosione e con proprietà di rapida disareaazione ed elevato indice di viscosità;

- viscosità raccomandata 15÷92 mm<sup>2</sup>/s
- viscosità limite d'avviamento 2000 mm<sup>2</sup>/s

Durante il normale funzionamento la temperatura dell'olio dovrà essere compresa tra 20° C e 65° C con valori limite compresi tra -20° C e 80° C con le guarnizioni in NBR e -15° C e 100° C con le stesse in Viton.

*It is advisable to use hydraulic oils of mineral origin with anti-foaming, antiwear, anti-oxidant and anti-corrosion characteristics and rapid air removal properties and a high viscosity index;*

- Recommended viscosity 15÷92 mm<sup>2</sup>/s (cSt)
- Start-up viscosity limit 2000 mm<sup>2</sup>/s (cSt)

*During normal operation, the oil temperature must be between 20°C and 65°C with limit values between -20°C and 80°C with NBR gasket and limit values between -15°C and 100°C with Viton gasket.*

### PRESSIONE DI ASPIRAZIONE • SUCTION PRESSURE

La pressione di esercizio in aspirazione deve essere compresa nell'intervallo 0.7 - 3 bar (assoluti).

Per valori superiori (fino a 30 bar) è necessario ricorrere ad anelli di tenuta per alte pressioni.

*The allowed working pressure supplied must be in the range 0.7 - 3 bar (absolute).*

*For higher values (up to 30 bar), it is necessary to use sealing ring for high pressures.*

### CONDOTTI DI ASPIRAZIONE • SUCTION PIPES

Particolare attenzione dovrà essere posta nel dimensionamento delle tubazioni (rigide o flessibili) evitando lunghezze sproporzionate, improvvise variazioni di sezione, piccoli raggi di curvatura scegliendo comunque sezioni dei condotti di aspirazione che garantiscano una velocità dell'olio compresa fra 0.6 e 2 m/s.

*Particular attention must be given to the sizing of rigid or flexible pipes, avoiding disproportionate lengths, sudden variations in cross section or small curvature radius, in any case selecting pipe cross-sections that guarantee an oil speed between 0.6 and 2 m/s.*

### FILTRAZIONE • FILTRATION

Per eliminare eventuali impurità presenti nell'olio e garantire una durata superiore alla pompa, è necessario introdurre nell'impianto un'efficace filtrazione verificandone periodicamente la funzionalità.

I livelli di filtrazione raccomandati sono i seguenti:

Utilizzo fino a 150 bar:

**21/19/16 (ISO 4406) classe 10 (NAS 1638)**

Utilizzo oltre 150 bar:

**20/18/15 (ISO 4406) classe 9 (NAS 1638)**

*In order to eliminate any oil impurity and to guarantee a longer duration of the pump, the system must be equipped with effective filtration, whose operation must be periodically checked.*

*The recommended filtration levels are as follows:*

*Up to 150 bar:*

**21/19/16 (ISO 4406) classe 10 (NAS 1638)**

*Over 150 bar:*

**20/18/15 (ISO 4406) classe 9 (NAS 1638)**

### NOTE INSTALLAZIONE • INSTALLATION NOTES

Prima di avviare l'impianto a regime, sono consigliati alcuni accorgimenti:

- Verificare che il senso di rotazione sia coerente con quello dell'albero da cui proviene il moto.
- Verificare che nelle flange di connessione alle porte di aspirazione e mandata non siano presenti trucioli, sporco o altro.
- Se la pompa è sottoposta a verniciatura, proteggere l'anello di tenuta verificando che la zona di contatto fra anello di tenuta e albero sia priva di polvere o di sedimenti abrasivi che possono accelerare le usure e causare delle perdite.
- Assicurarsi che il giunto utilizzato per la trasmissione compensi disallineamenti assiali che potrebbero pregiudicare l'integrità del motore.

*Before starting the system setting, some precautions are recommended:*

- Check that the direction of rotation is consistent with the drive shaft one.
- Remove all dirt, chips and all foreign bodies from flanges connecting inlet and delivery ports.
- Protect the drive shaft sealing ring during pump painting; check that the contact area between ring and shaft is clean: dust or abrasive sediments could accelerate the wear and cause leakages.
- Make sure that the transmission joint balances any axial misalignment that might compromise the engine working.

## POMPE AD INGRANAGGI INFORMAZIONI TECNICHE GEAR PUMPS TECHNICAL INFORMATION

• In caso di carichi radiali e/o assiali sull'albero della pompa (come ad esempio quando il trascinamento viene effettuato tramite pulegge e cinghie) è necessario optare per le versioni disponibili con supporto rinforzato.

• Il giunto di collegamento fra alberi scanalati dovrà essere opportunamente lubrificato, libero di muoversi assialmente e di lunghezza adatta a coprire tutta l'estensione dei due alberi (motore e pompa).

### Durante il primo avviamento:

• scollegare lo scarico della pompa per permettere di spurgare l'aria nel circuito e, in caso di valvole di massima, tarare le valvole limitatrici di pressione al minimo valore.

• Evitare partenze sotto carico in condizioni di bassa temperatura o di lunghi periodi di inattività.

• Per verificare l'effettivo riempimento sfiatare il circuito dopo un primo avviamento di qualche istante dove è stata attivata tutta la componentistica.

• Tenendo controllata la temperatura del fluido e delle parti in movimento e la velocità di rotazione è infine possibile aumentare la pressione fino al raggiungimento delle condizioni di esercizio previste che devono mantenersi entro i limiti indicati del presente catalogo.

• *With radial and/or axial loads on the pump shaft (such as when driving is carried out through pulleys or chains) use the available versions with strengthen shaft.*

• *The coupling joint between the spline shafts has to be properly lubricated, free to move axially and of a suitable length to cover both motor and pump shafts.*

### Installation notes:

• *disconnect the drain pump to bleed off the air in the circuit and set the pressure relief valve at the minimum value.*

• *Do not start the system under load at low temperatures or after long stops.*

• *Check the whole system filling by bleeding off the whole air amount after few minutes of system working.*

• *Increase the pressure until you reach the operating values by keeping checked the fluid and the moving parts temperature and the rotation speed. Maintain the set values within the limits specified in this catalogue.*

## DEFINIZIONE DEL VERSO DI ROTAZIONE GUARDANDO L'ALBERO DI TRASCINAMENTO DEFINITION OF ROTATION DIRECTION BY LOOKING AT THE DRIVE SHAFT

USCITA FLUIDO AD ALTA PRESSIONE  
HIGH PRESSURE FLUID EXIT

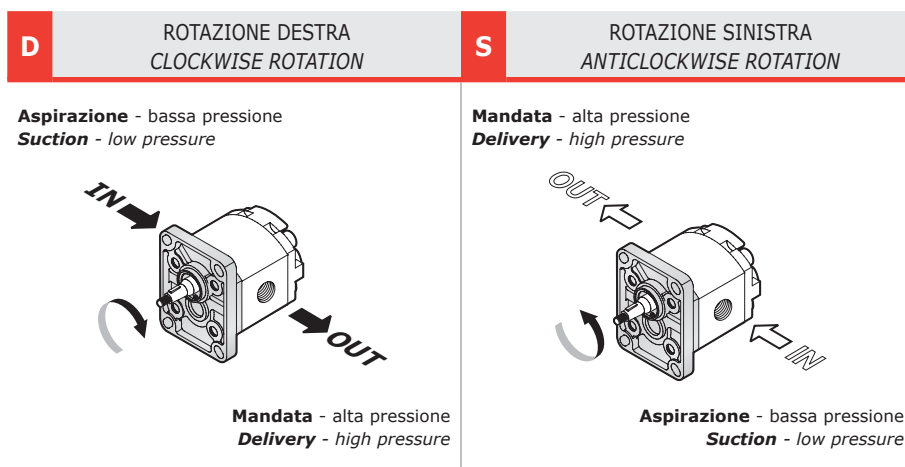

### SENSO DI ROTAZIONE • ROTATION WISE

Il senso di rotazione viene definito S (sinistro) e D (destra) osservando l'albero frontalmente. In caso di rotazione sinistra "S" l'aspirazione sarà a destra dell'albero di trascinamento mentre la mandata sarà alla sua sinistra; il contrario sarà per pompa monodirezionale destra "D". In fase di ordine è necessario precisare il senso di rotazione desiderato, oppure intervenire modificando l'assetto interno come illustrato di seguito (inversione).

*The rotation wise is defined as S (anticlockwise) or D (clockwise) by observing the shaft from the front. In case of anticlockwise rotation "S" the suction will be to the right of the drive shaft while the delivery will be to your left; the opposite will be for monodirectional pump right "D". When ordering, it is necessary to specify the required rotation; direction or it is possible to modify the internal structure as illustrated below (reversal).*

## POMPE AD INGRANAGGI INFORMAZIONI TECNICHE

### GEAR PUMPS TECHNICAL INFORMATION

#### INVERSIONE • REVERSAL

Il senso di rotazione delle pompe è evidenziato da una freccia sulla targhetta.

La targhetta è posizionata sul corpo. (vedi pag.10)

L'inversione del senso di rotazione di una pompa si esegue nel seguente modo:

- Smontare la pompa come da fig. 1.
- Sfilare gli ingranaggi C e D e rimontarli secondo la fig. 2
- Rimontare la boccola B nella stessa posizione della fig. 1
- Capovolgere la flangia A e rimontare la pompa serrando le viti con una chiave dinamometrica.
- Per le pompe 3PG, smontare solo la flangia anteriore.

*Pump wise rotation is indicated by an arrow on the label.*

*The plate is placed on the body (see page 10).*

*How to invert the pump wise rotation:*

- *Disassemble pump as shown in fig. 1.*
- *Pull off C - D gears and reassemble them according to fig. 2.*
- *Reassemble B bushing as before.*
- *Reverse the A flange and reassemble the pump by tightening the screws by dynamometric wrench.*
- *For the 3GP pumps, disassemble only front flange.*

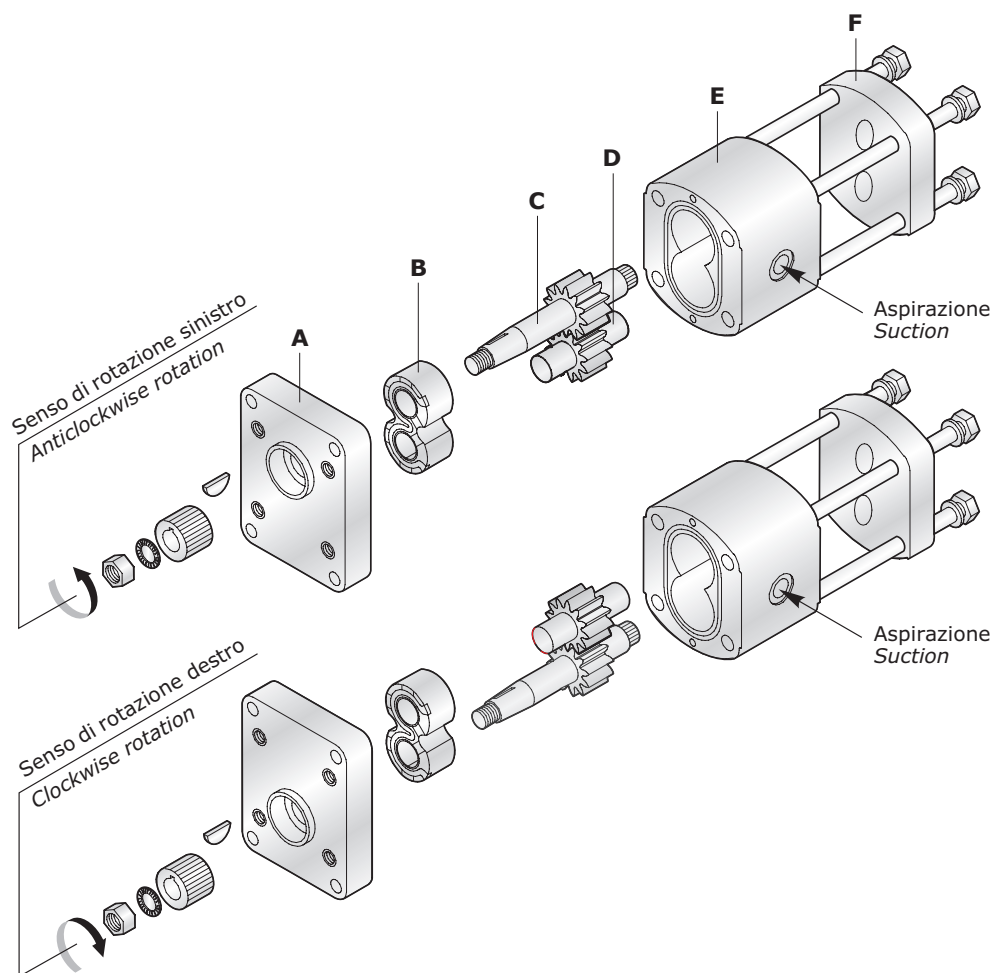

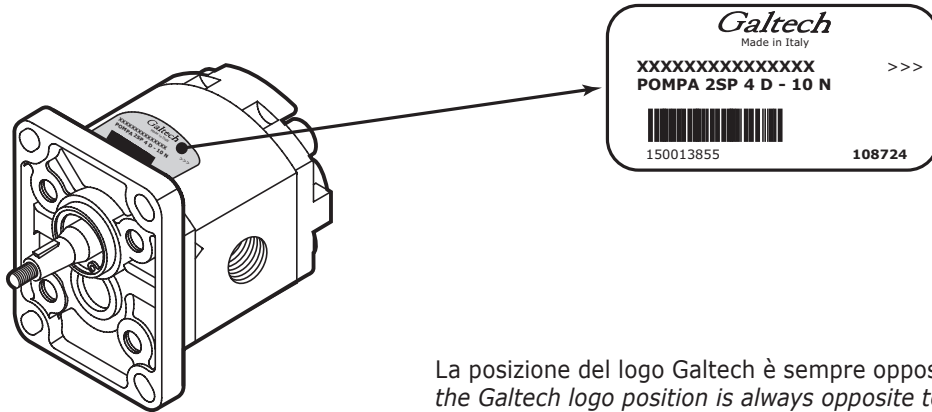
**POMPE AD INGRANAGGI INFORMAZIONI TECNICHE**  
**GEAR PUMPS TECHNICAL INFORMATION**
**TARGHETTA • PLATE**

La posizione del logo Galtech è sempre opposta alla flangia.  
 the Galtech logo position is always opposite to the flange.



TIPO DI POMPA - PUMP TYPE	GRUPPO - GROUP 1SP	GRUPPO - GROUP 2SP	GRUPPO - GROUP 3GP
<b>Numero di viti</b> <b>Screws number</b>	4	4	16
<b>Tipo di filetto</b> <b>Thread type</b>	M8	M10	M10
<b>Coppia di serraggio viti</b> <b>Screw tightening torque</b>	30 Nm / 266 in-lbs	50 Nm / 443 in-lbs	60 Nm / 531 in-lbs
<b>Tipo di giunto</b> <b>Coupling type</b>	1IS 12M	2IS 14M / 2IS 15M	3IS 18M
<b>Coppia di serraggio dado giunto</b> <b>Nut coupling tightening torque</b>	9 ÷ 10 Nm / 80 ÷ 90 in-lbs	22 ÷ 25 Nm / 195 ÷ 221 in-lbs 32 ÷ 35 Nm / 283 ÷ 310 in-lbs	50 ÷ 55 Nm / 443 ÷ 487 in-lbs

**POMPE AD INGRANAGGI INFORMAZIONI TECNICHE**  
**GEAR PUMPS TECHNICAL INFORMATION**

**DEFINIZIONE DELLE PRESSIONI • DEFINITION OF PRESSURES**

Le pompe possono essere sottoposte alle pressioni P1, P2, P3 indicate nelle tabelle delle prestazioni.

The pumps can be subjected to the P1, P2 or P3 pressures shown in the performance tables.

Il grafico seguente ne illustra le definizioni e l'applicabilità rispettando i limiti delle velocità di rotazione riportati.

The following diagram illustrates the definitions and applicability by respecting the included rotation speed limits.

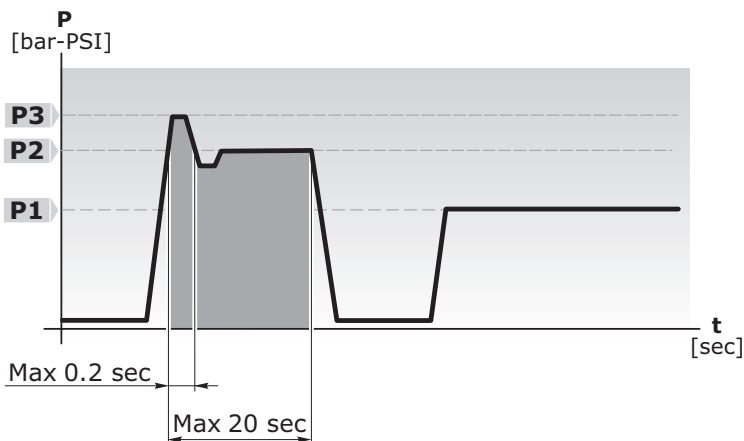

- P3** Pressione massima di picco  
Max peak pressure
- P2** Pressione massima intermittente  
Max intermittent pressure
- P1** Pressione massima continua  
Continuos max pressure

MISURE IDRAULICHE - HYDRAULIC MEASURES			FORMULE UTILI - USEFUL FORMULAS		FATTORE CONVERSIONE - CONVERSION FACTOR	
<b>Q</b>	Portata Flow	[l/min] [Gal/min]	$Q = \frac{V \cdot \eta_v \cdot n}{1000}$	[l/min]	1 l/min	0.2641 US Gal/min
<b>M</b>	Coppia Torque	[Nm] [lfb.in]	$M = \frac{\Delta p \cdot V}{62.83 \cdot \eta_m}$	[Nm]	1 Nm	8.851 in-lbs
<b>P</b>	Potenza Power	[kW] [HP]	$P = \frac{\Delta p \cdot V \cdot n}{600 \cdot 1000 \cdot \eta_t}$	[kW]	1 kW	1.34 HP
<b>V</b>	Cilindrata Displacement	[cm³/giro] [in³/rev]	$P = \frac{\Delta p \cdot V \cdot n}{395934 \cdot \eta_t}$	[HP]	1 cm³/giro	0.061 in³/rev
<b>n</b>	Velocità Speed	[min⁻¹]			1 bar	14.5 PSI
<b>Δp</b>	Pressione Pressure	[bar] [PSI]			1 mm	0.0394 in
<b>η<sub>v</sub></b>	Rendimento volumetrico Volumetric efficiency				1 kg	2.205 lbs
<b>η<sub>m</sub></b>	Rendimento meccanico Mechanical efficiency					
<b>η<sub>t</sub></b>	Rendimento totale Overall efficiency					

**POMPE AD INGRANAGGI PRESTAZIONI**  
**GEAR PUMPS PERFORMANCES**
**GRUPPO GROUP 1SP**

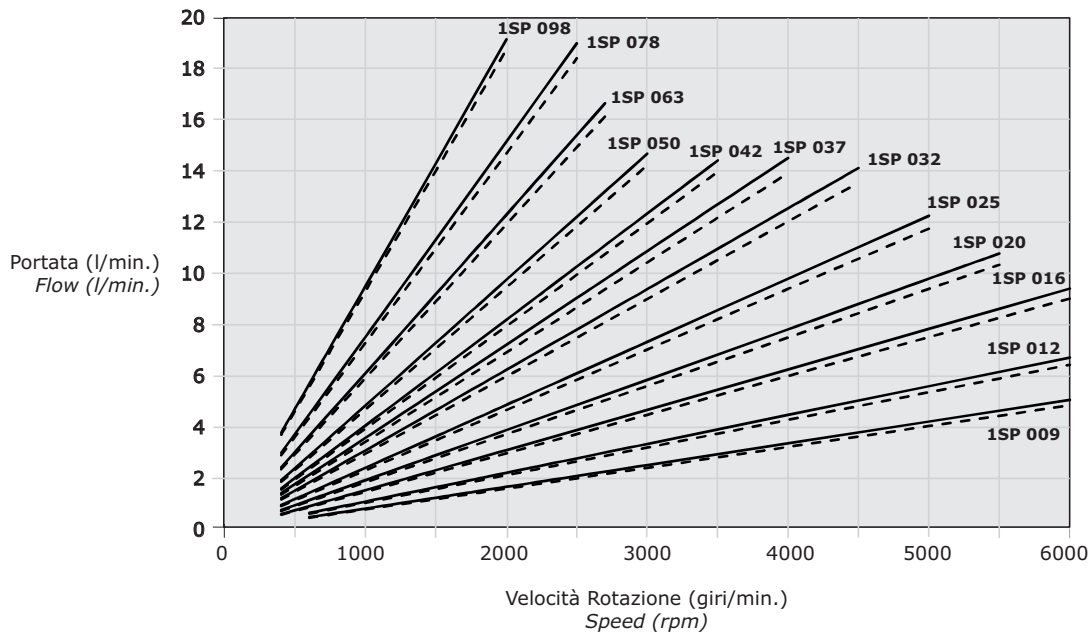
 DIAGRAMMA PORTATA - VELOCITÀ DI ROTAZIONE  
 FLOW - ROTATION SPEED CHART

**GRUPPO GROUP 1SP**

 DIAGRAMMI POTENZE  
 POWER DIAGRAM

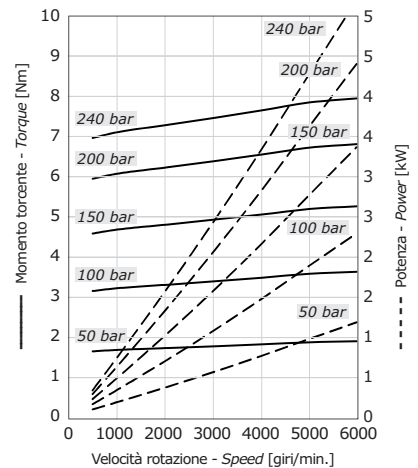
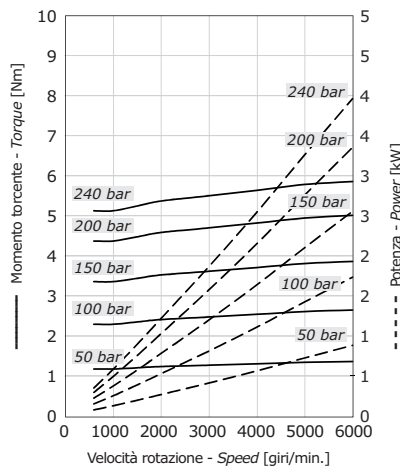
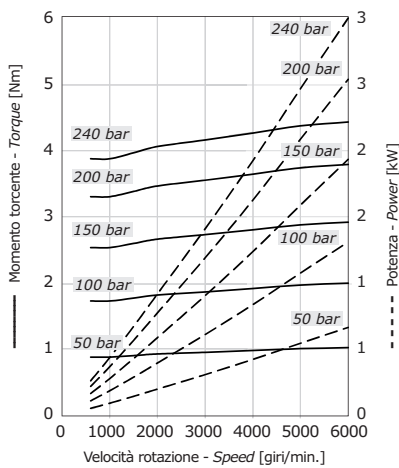
 Grafici rilevati a banco di collaudo a 40°C con olio VG46  
 Diagrams recorded on test bench at 40°C with VG46 mineral oil

**1SP 009**
**1SP 012**
**1SP 016**

**POMPE AD INGRANAGGI PRESTAZIONI**  
**GEAR PUMPS PERFORMANCES**

**1SP 020**

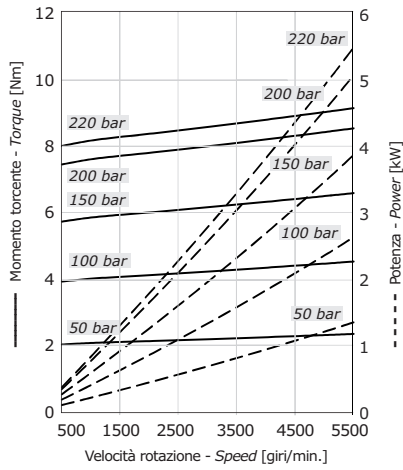

**1SP 025**

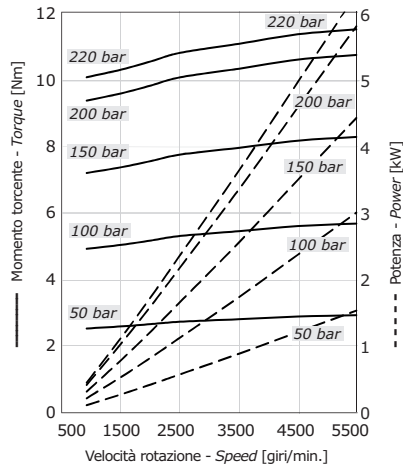

**1SP 032**

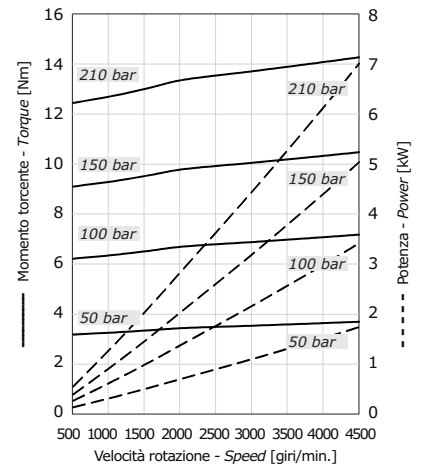

**1SP 037**

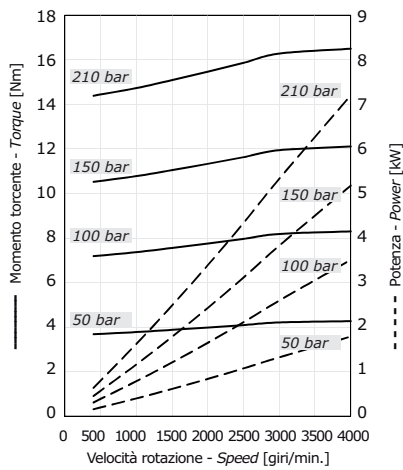

**1SP 042**

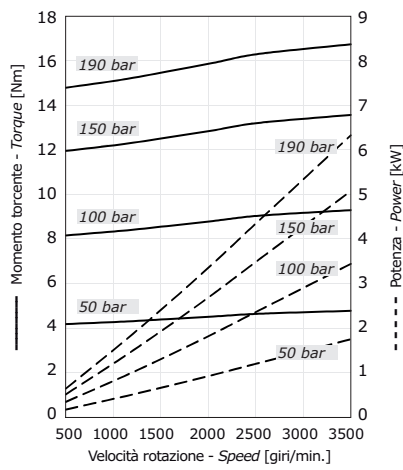

**1SP 050**

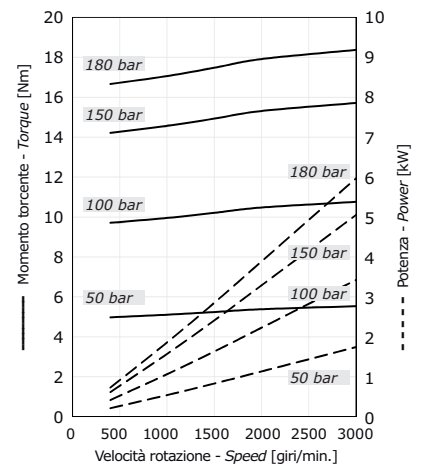

**1SP 063**

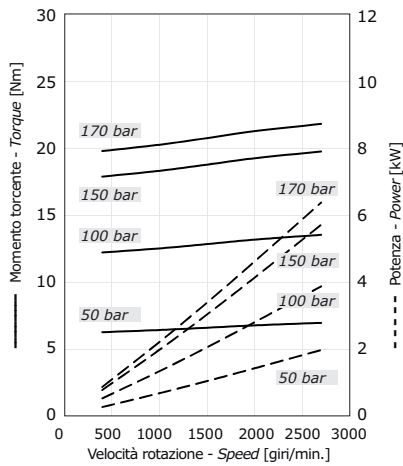

**1SP 078**

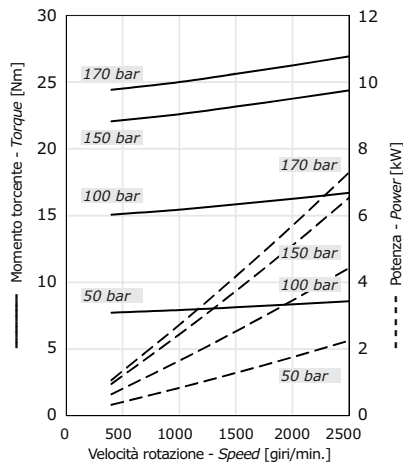

**1SP 098**

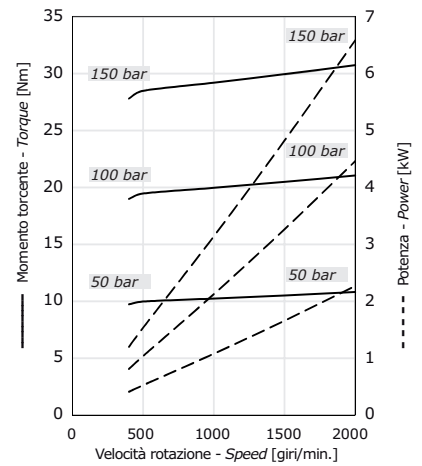

**POMPE AD INGRANAGGI PRESTAZIONI**  
**GEAR PUMPS PERFORMANCES**
**GRUPPO GROUP 2SP**

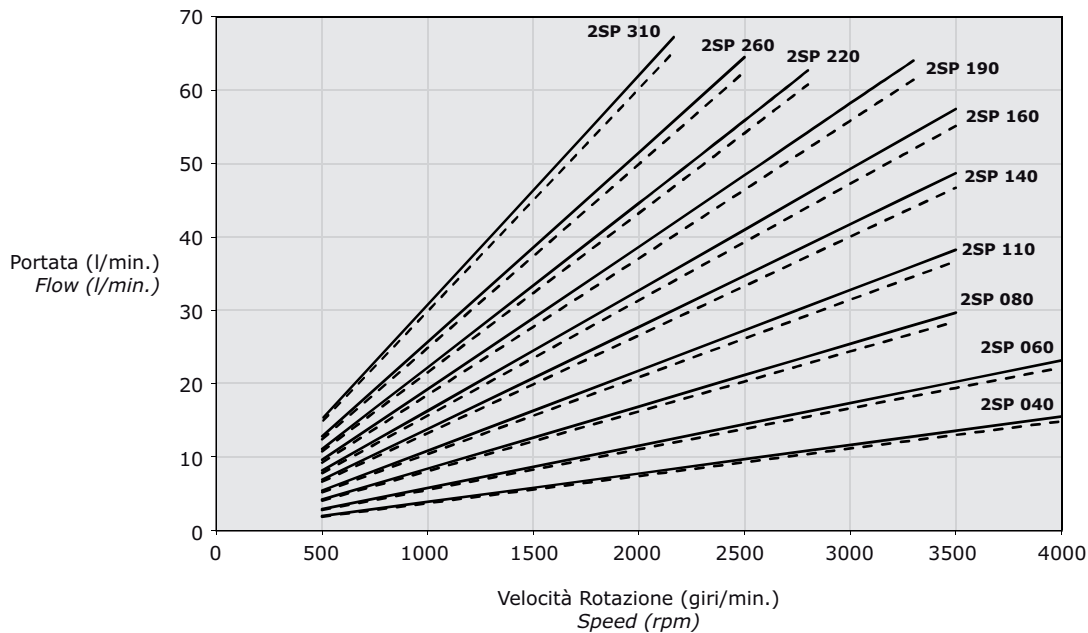
 DIAGRAMMA PORTATA - VELOCITÀ DI ROTAZIONE  
 FLOW - ROTATION SPEED CHART

**GRUPPO GROUP 2SP**

 DIAGRAMMI POTENZE  
 POWER DIAGRAM

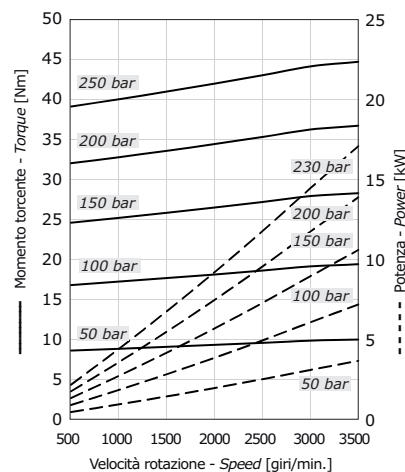
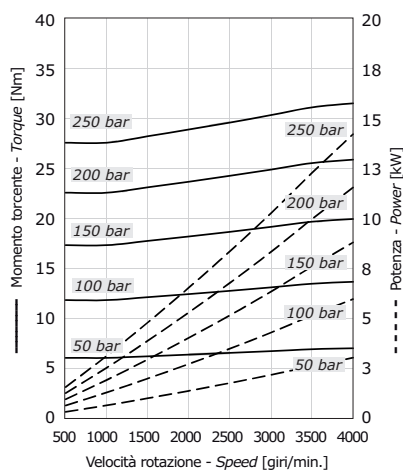
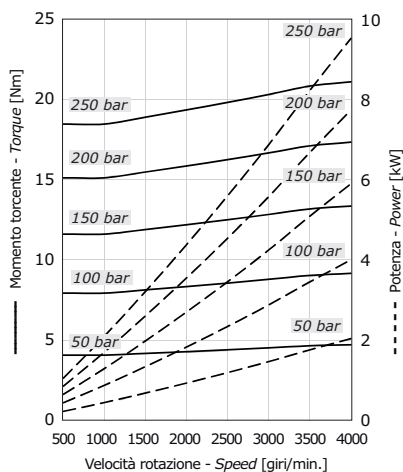
Grafici rilevati a banco di collaudo a 40°C con olio VG46  
 Diagrams recorded on test bench at 40°C with VG46 mineral oil

**2SP 040**
**2SP 060**
**2SP 080**



**POMPE AD INGRANAGGI PRESTAZIONI**  
**GEAR PUMPS PERFORMANCES**

**2SP 110**

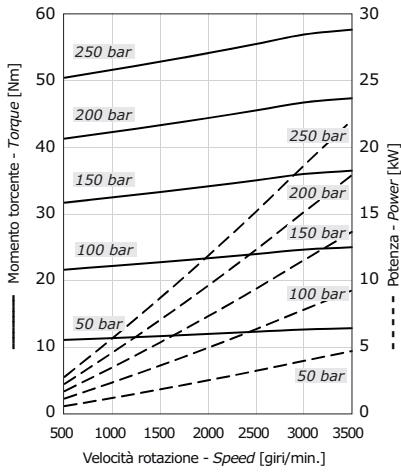

**2SP 140**

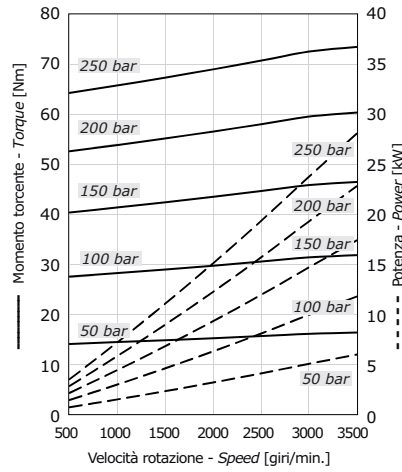

**2SP 160**

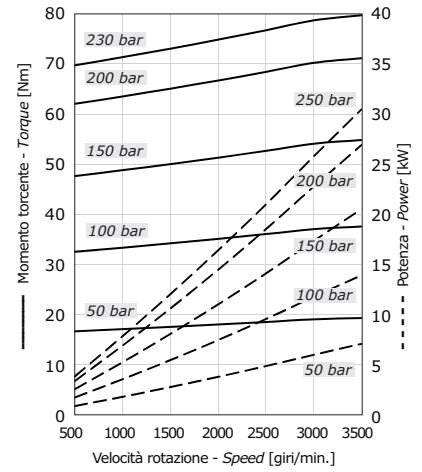

**2SP 190**

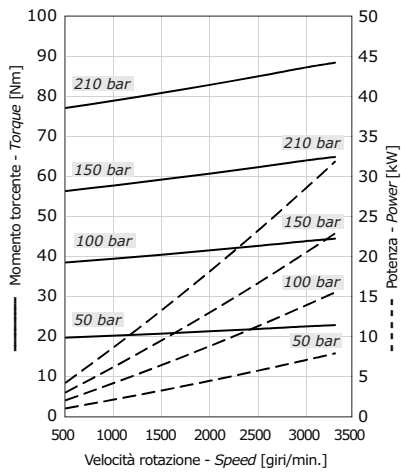

**2SP 220**

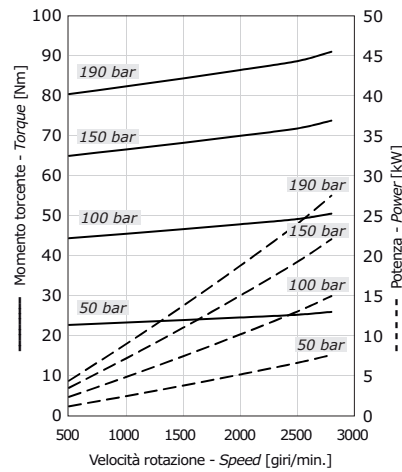

**2SP 260**

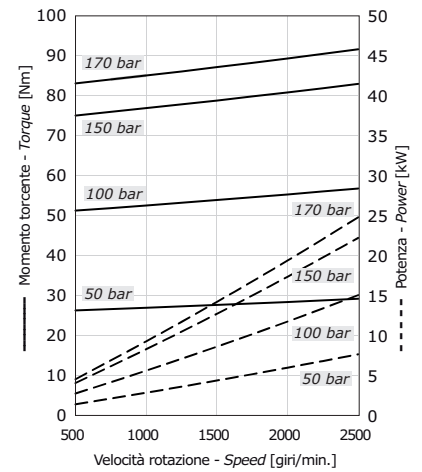

**2SP 310**

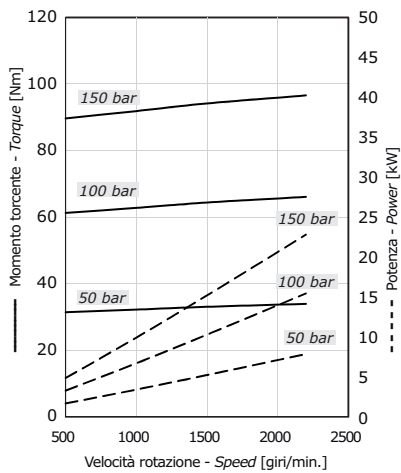

**POMPE AD INGRANAGGI PRESTAZIONI**  
**GEAR PUMPS PERFORMANCES**
**GRUPPO GROUP 3GP**

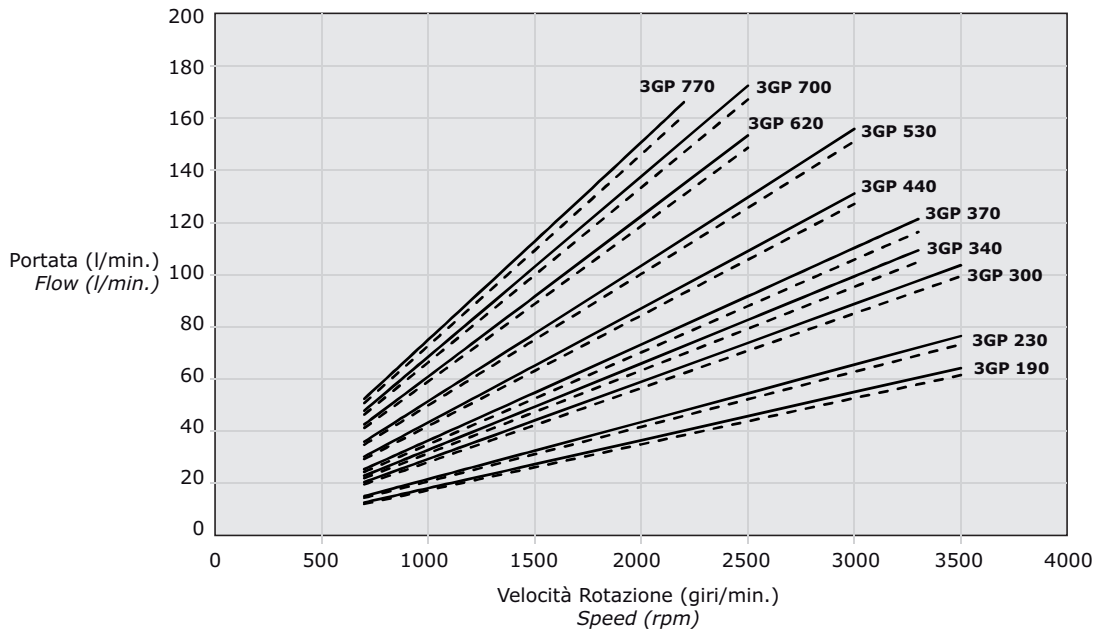
 DIAGRAMMA PORTATA - VELOCITÀ DI ROTAZIONE  
 FLOW - ROTATION SPEED CHART

**GRUPPO GROUP 3GP**

 DIAGRAMMI POTENZE  
 POWER DIAGRAM

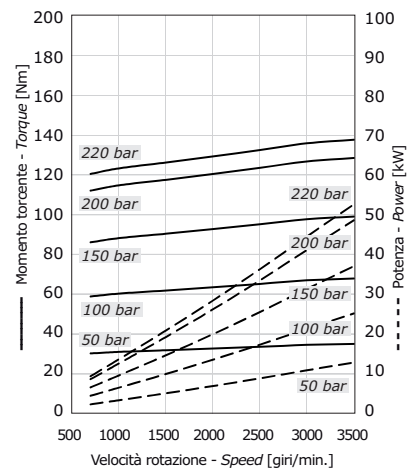
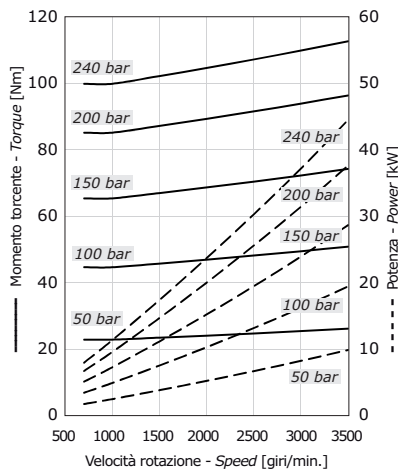
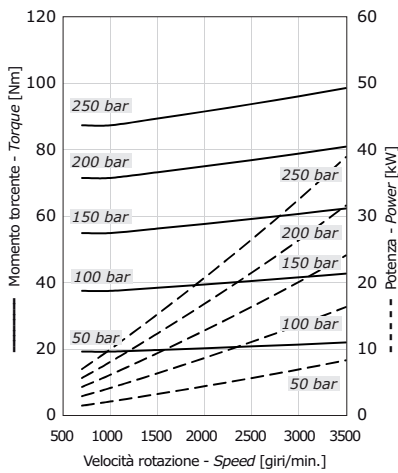
Grafici rilevati a banco di collaudo a 40°C con olio VG46  
 Diagrams recorded on test bench at 40°C with VG46 mineral oil

**3GP 190**
**3GP 230**
**3GP 300**

**POMPE AD INGRANAGGI PRESTAZIONI**  
**GEAR PUMPS PERFORMANCES**

**3GP 340**

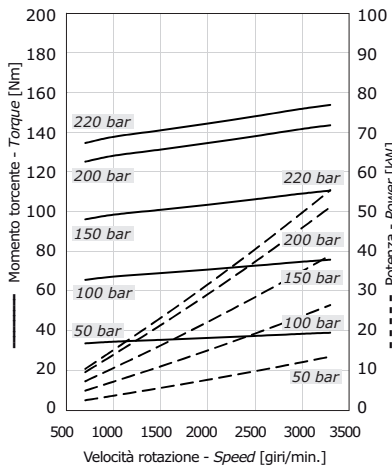

**3GP 370**

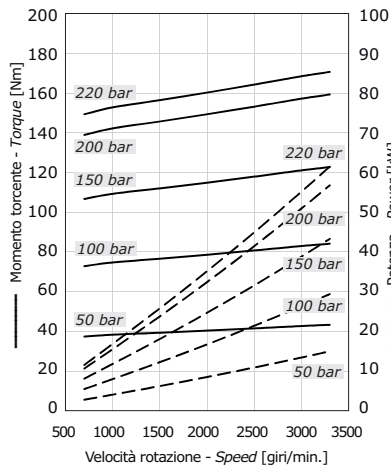

**3GP 440**

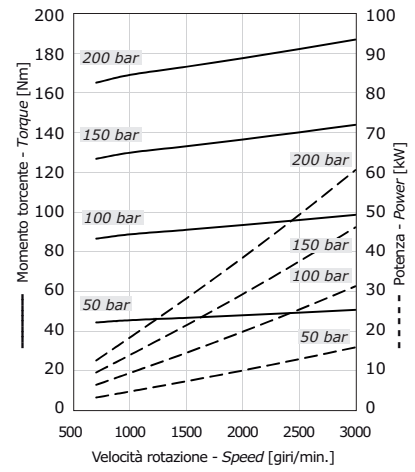

**3GP 530**

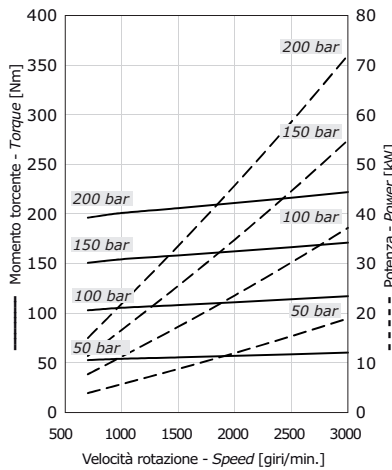

**3GP 620**

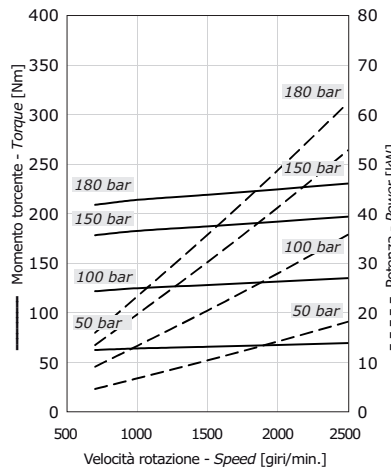

**3GP 700**

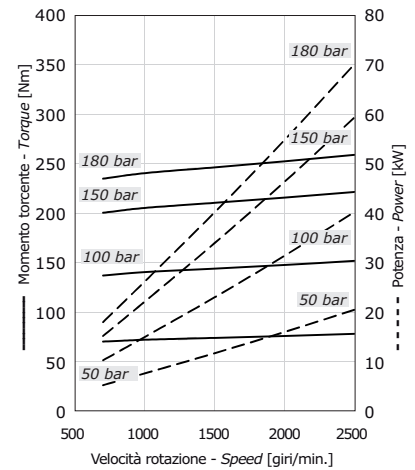

**3GP 770**

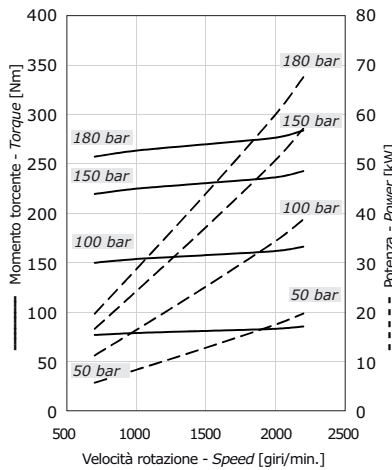

**POMPE AD INGRANAGGI GRUPPO 1SP**  
**GEAR PUMPS GROUP 1SP**
**FLANGIA EUROPEA EUR STANDARD FLANGE**

GRUPPO GROUP 1SP	CILINDRATA DISPLACEMENT		PRESSIONE MAX - MAX PRESSURE						VELOCITÀ MAX MAX SPEED	PORTATA MAX MAX FLOW		VELOCITÀ MIN MIN SPEED
	cm <sup>3</sup> /giro	in <sup>3</sup> /rev	P1		P2		P3			l/min	Gal/min	
			bar	psi	bar	psi	bar	psi	giri/min - rpm			giri/min - rpm
1SP 009	0.89	0.05	260	3770	280	4060	290	4205	6000	5.3	1.40	600
1SP 012	1.18	0.07	260	3770	280	4060	290	4205	6000	7.1	1.88	600
1SP 016	1.6	0.10	260	3770	280	4060	290	4205	6000	9.6	2.54	400
1SP 020	2.0	0.12	260	3770	280	4060	290	4205	5500	11	2.91	400
1SP 025	2.5	0.15	260	3770	280	4060	290	4205	5000	12.5	3.30	400
1SP 032	3.2	0.20	260	3770	280	4060	290	4205	4500	14.4	3.80	400
1SP 037	3.7	0.23	250	3625	270	3915	280	4060	4000	14.8	3.91	400
1SP 042	4.2	0.26	250	3625	270	3915	280	4060	3500	14.7	3.88	400
1SP 050	5.0	0.31	250	3625	270	3915	280	4060	3000	15	3.96	400
1SP 063	6.3	0.38	170	2465	190	2755	210	3045	2700	17	4.49	400
1SP 078	7.76	0.47	170	2465	190	2755	210	3045	2500	19.4	5.13	400
1SP 098	9.78	0.60	150	2175	170	2465	190	2755	2000	19.6	5.18	400

Nota - Per valori di pressione superiori a quelli indicati contattare il Servizio Commerciale.  
 Note - for higher pressure values please contact our Sales Dpt.

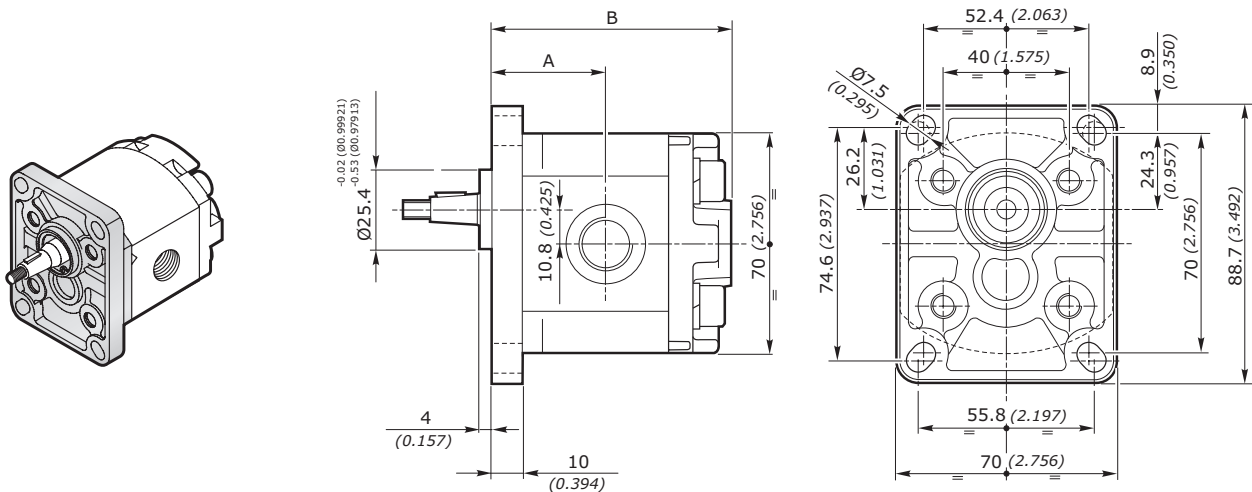
**DIMENSIONI • DIMENSIONS**

GRUPPO - GROUP 1	A		B		MASSA - MASS	
	mm	inch	mm	inch	kg	lbs
1SP 009	34.80	1.370	73.6	2.898	0.91	2.01
1SP 012	35.35	1.392	74.7	2.941	0.93	2.05
1SP 016	36.20	1.425	76.4	3.008	0.95	2.09
1SP 020	36.95	1.455	77.9	3.067	0.97	2.14
1SP 025	37.95	1.494	79.9	3.146	1.00	2.21
1SP 032	39.30	1.547	82.6	3.252	1.04	2.29
1SP 037	40.30	1.587	84.6	3.331	1.07	2.36
1SP 042	41.25	1.624	86.5	3.406	1.10	2.43
1SP 050	42.80	1.685	89.6	3.528	1.14	2.51
1SP 063	45.35	1.785	94.7	3.728	1.22	2.69
1SP 078	48.20	1.898	100.4	3.953	1.30	2.87
1SP 098	52.15	2.053	108.3	4.264	1.41	3.11

**POMPE AD INGRANAGGI GRUPPO 1SP**  
**GEAR PUMPS GROUP 1SP**

**FLANGIA SAE** **SAEAA** **SAE FLANGE**

GRUPPO GROUP 1SP	CILINDRATA DISPLACEMENT		PRESSIONE MAX - MAX PRESSURE						VELOCITÀ MAX MAX SPEED	PORTATA MAX MAX FLOW		VELOCITÀ MIN MIN SPEED
	cm <sup>3</sup> /giro	in <sup>3</sup> /rev	P1		P2		P3		giri/min - rpm	l/min	Gal/min	giri/min - rpm
			bar	psi	bar	psi	bar	psi				
1SP 009	0.89	0.05	260	3770	280	4060	290	4205	6000	5.3	1.40	600
1SP 012	1.18	0.07	260	3770	280	4060	290	4205	6000	7.1	1.88	600
1SP 016	1.6	0.10	260	3770	280	4060	290	4205	6000	9.6	2.54	400
1SP 020	2.0	0.12	260	3770	280	4060	290	4205	5500	11	2.91	400
1SP 025	2.5	0.15	260	3770	280	4060	290	4205	5000	12.5	3.30	400
1SP 032	3.2	0.20	260	3770	280	4060	290	4205	4500	14.4	3.80	400
1SP 037	3.7	0.23	250	3625	270	3915	280	4060	4000	14.8	3.91	400
1SP 042	4.2	0.26	250	3625	270	3915	280	4060	3500	14.7	3.88	400
1SP 050	5.0	0.31	250	3625	270	3915	280	4060	3000	15	3.96	400
1SP 063	6.3	0.38	170	2465	190	2755	210	3045	2700	17	4.49	400
1SP 078	7.76	0.47	170	2465	190	2755	210	3045	2500	19.4	5.13	400
1SP 098	9.78	0.60	150	2175	170	2465	190	2755	2000	19.6	5.18	400

Nota - Per valori di pressione superiori a quelli indicati contattare il Servizio Commerciale.  
Note - for higher pressure values please contact our Sales Dpt.

**DIMENSIONI • DIMENSIONS**

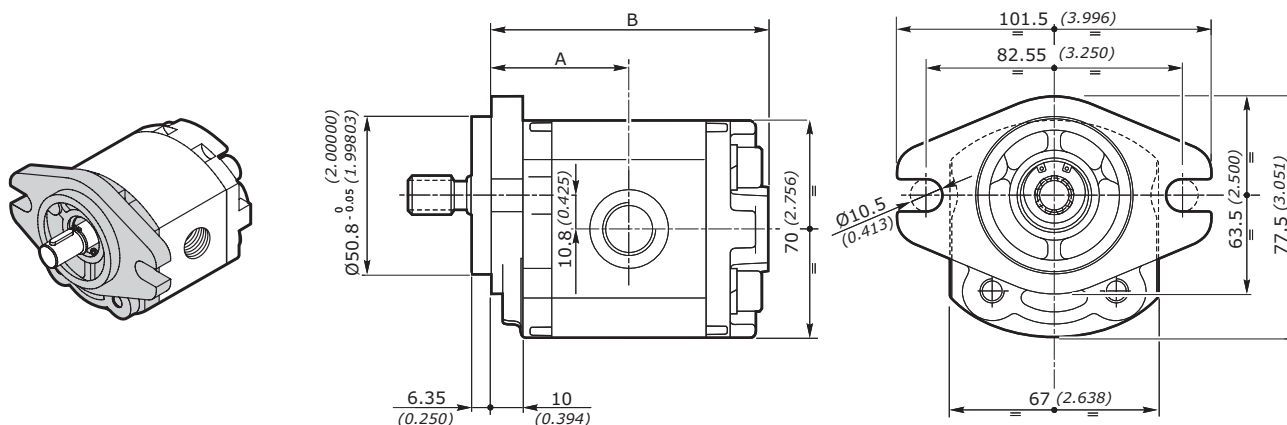

GRUPPO - GROUP 1	A		B		MASSA - MASS	
	mm	inch	mm	inch	kg	lbs
1SP 009	38.30	1.508	77.10	3.035	0.91	2.01
1SP 012	38.85	1.530	78.20	3.079	0.93	2.05
1SP 016	39.70	1.563	79.90	3.146	0.95	2.09
1SP 020	40.45	1.593	81.40	3.205	0.97	2.14
1SP 025	41.45	1.632	83.40	3.283	1.00	2.21
1SP 032	42.80	1.685	86.10	3.390	1.04	2.29
1SP 037	43.80	1.724	88.10	3.469	1.07	2.36
1SP 042	44.75	1.762	90.00	3.543	1.10	2.43
1SP 050	46.30	1.823	93.10	3.665	1.14	2.51
1SP 063	48.85	1.923	98.20	3.866	1.22	2.69
1SP 078	51.70	2.035	103.90	4.091	1.30	2.87
1SP 098	55.65	2.191	111.80	4.402	1.41	3.11

**POMPE AD INGRANAGGI GRUPPO 1SP**  
**GEAR PUMPS GROUP 1SP**
**FLANGIA PER MINICENTRALINA MC32 POWER-PACK FLANGE**

GRUPPO GROUP 1SP	CILINDRATA DISPLACEMENT		PRESSIONE MAX - MAX PRESSURE						VELOCITÀ MAX MAX SPEED		PORTATA MAX MAX FLOW		VELOCITÀ MIN MIN SPEED
	cm <sup>3</sup> /giro	in <sup>3</sup> /rev	P1		P2		P3		giri/min - rpm	l/min	Gal/min	giri/min - rpm	
			bar	psi	bar	psi	bar	psi					
<b>1SP 009</b>	0.89	0.05	260	3770	280	4060	290	4205	6000	5.3	1.40	600	
<b>1SP 012</b>	1.18	0.07	260	3770	280	4060	290	4205	6000	7.1	1.88	600	
<b>1SP 016</b>	1.6	0.10	260	3770	280	4060	290	4205	6000	9.6	2.54	400	
<b>1SP 020</b>	2.0	0.12	260	3770	280	4060	290	4205		11	2.91	400	
<b>1SP 025</b>	2.5	0.15	260	3770	280	4060	290	4205	5000	12.5	3.30	400	
<b>1SP 032</b>	3.2	0.20	260	3770	280	4060	290	4205	4500	14.4	3.80	400	
<b>1SP 037</b>	3.7	0.23	250	3625	270	3915	280	4060	4000	14.8	3.91	400	
<b>1SP 042</b>	4.2	0.26	250	3625	270	3915	280	4060	3500	14.7	3.88	400	
<b>1SP 050</b>	5.0	0.31	250	3625	270	3915	280	4060	3000	15	3.96	400	
<b>1SP 063</b>	6.3	0.38	170	2465	190	2755	210	3045	2700	17	4.49	400	
<b>1SP 078</b>	7.76	0.47	170	2465	190	2755	210	3045	2500	19.4	5.13	400	
<b>1SP 098</b>	9.78	0.60	150	2175	170	2465	190	2755	2000	19.6	5.18	400	

Nota - Per valori di pressione superiori a quelli indicati contattare il Servizio Commerciale.  
 Note - for higher pressure values please contact our Sales Dpt.

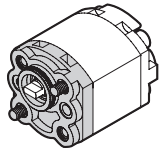
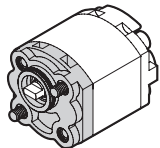
**MC32**

**MC32N**

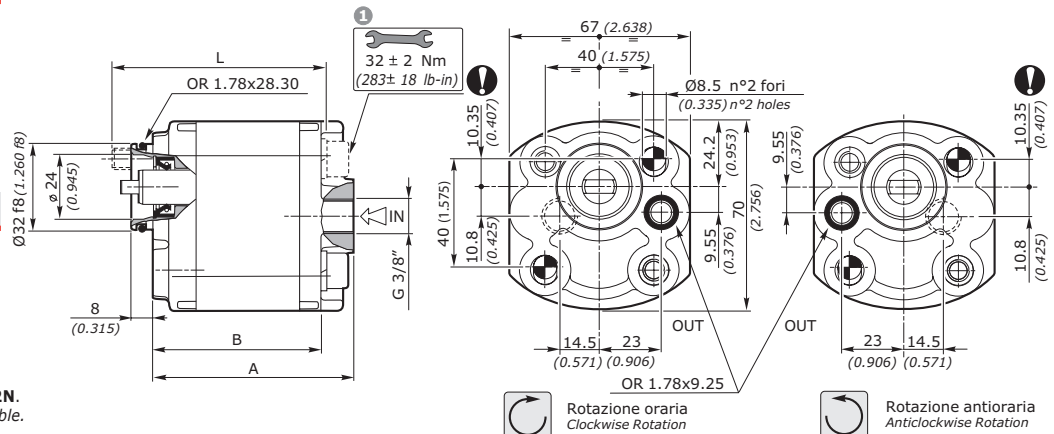
E' disponibile la flangia senza foro **MC32N**.  
 The flange without hole **MC32N** is available.

**DIMENSIONI • DIMENSIONS**

1 Coppia di serraggio viti: 32 ± 2Nm (viti classe 10.9-12.9 UNI EN 20898/1)  
 Il kit viti per il fissaggio della pompa è da ordinare separatamente.  
 Codice di ordinazione: **0019W** (+ lunghezza L - vedi tabella)

Il fissaggio della pompa può essere effettuato con 2 viti prigioniere (25 ± 2Nm).  
 Fissare la pompa mediante dadi autobloccanti (32 ± 2 Nm).

1 Screw tightening torque: 283 ± 18 lb-in (screws 10.9-12.9 UNI EN 20898/1).  
 The screw kit for the pump assembly should be ordered separately.  
 Ordering code: **0019W** (+ length L - see table)

The pump assembling should be made by 2 screws (221 ± 18 lb-in).  
 Fix the pump by self-locking nuts (283 ± 18 lb-in).

GRUPPO - GROUP 1	A		B		L 1		MASSA - MASS	
	mm	inch	mm	inch	mm	inch	kg	lbs
<b>1SP 009</b>	73.1	2.878	61.6	2.425	80	3.150	0.91	2.01
<b>1SP 012</b>	74.2	2.921	62.7	2.469	80	3.150	0.93	2.05
<b>1SP 016</b>	75.9	2.988	64.4	2.535	80	3.150	0.95	2.09
<b>1SP 020</b>	77.4	3.047	65.9	2.594	80	3.150	0.97	2.14
<b>1SP 025</b>	79.4	3.126	67.9	2.673	85	3.346	1.00	2.21
<b>1SP 032</b>	82.1	3.232	70.6	2.780	85	3.346	1.04	2.29
<b>1SP 037</b>	84.1	3.311	72.6	2.858	90	3.543	1.07	2.36
<b>1SP 042</b>	86.0	3.386	74.5	2.933	90	3.543	1.10	2.43
<b>1SP 050</b>	89.1	3.508	77.6	3.055	95	3.740	1.14	2.51
<b>1SP 063</b>	94.2	3.709	82.7	3.256	100	3.937	1.22	2.69
<b>1SP 078</b>	99.9	3.933	88.4	3.480	105	4.134	1.30	2.87
<b>1SP 098</b>	107.8	4.244	96.3	3.791	115	4.528	1.41	3.11

**POMPE AD INGRANAGGI GRUPPO 1SP**  
**GEAR PUMPS GROUP 1SP**

**FLANGIA TEDESCA FISSAGGIO MINICENTRALINA E32BX POWER-PACK FIXING GERMAN FLANGE**

GRUPPO GROUP 1SP	CILINDRATA DISPLACEMENT		PRESSIONE MAX - MAX PRESSURE						VELOCITÀ MAX MAX SPEED		PORTATA MAX MAX FLOW		VELOCITÀ MIN MIN SPEED
			P1		P2		P3						
	cm³/giro	in³/rev	bar	psi	bar	psi	bar	psi	giri/min - rpm	l/min	Gal/min	giri/min - rpm	
<b>1SP 009</b>	0.89	0.05	260	3770	280	4060	290	4205	6000	5.3	1.40	600	
<b>1SP 012</b>	1.18	0.07	260	3770	280	4060	290	4205	6000	7.1	1.88	600	
<b>1SP 016</b>	1.6	0.10	260	3770	280	4060	290	4205	6000	9.6	2.54	400	
<b>1SP 020</b>	2.0	0.12	260	3770	280	4060	290	4205	5500	11	2.91	400	
<b>1SP 025</b>	2.5	0.15	260	3770	280	4060	290	4205	5000	12.5	3.30	400	
<b>1SP 032</b>	3.2	0.20	260	3770	280	4060	290	4205	4500	14.4	3.80	400	
<b>1SP 037</b>	3.7	0.23	250	3625	270	3915	280	4060	4000	14.8	3.91	400	
<b>1SP 042</b>	4.2	0.26	250	3625	270	3915	280	4060	3500	14.7	3.88	400	
<b>1SP 050</b>	5.0	0.31	250	3625	270	3915	280	4060	3000	15	3.96	400	
<b>1SP 063</b>	6.3	0.38	170	2465	190	2755	210	3045	2700	17	4.49	400	
<b>1SP 078</b>	7.76	0.47	170	2465	190	2755	210	3045	2500	19.4	5.13	400	
<b>1SP 098</b>	9.78	0.60	150	2175	170	2465	190	2755	2000	19.6	5.18	400	

Nota - Per valori di pressione superiori a quelli indicati contattare il Servizio Commerciale.  
Note - for higher pressure values please contact our Sales Dpt.

**DIMENSIONI • DIMENSIONS**

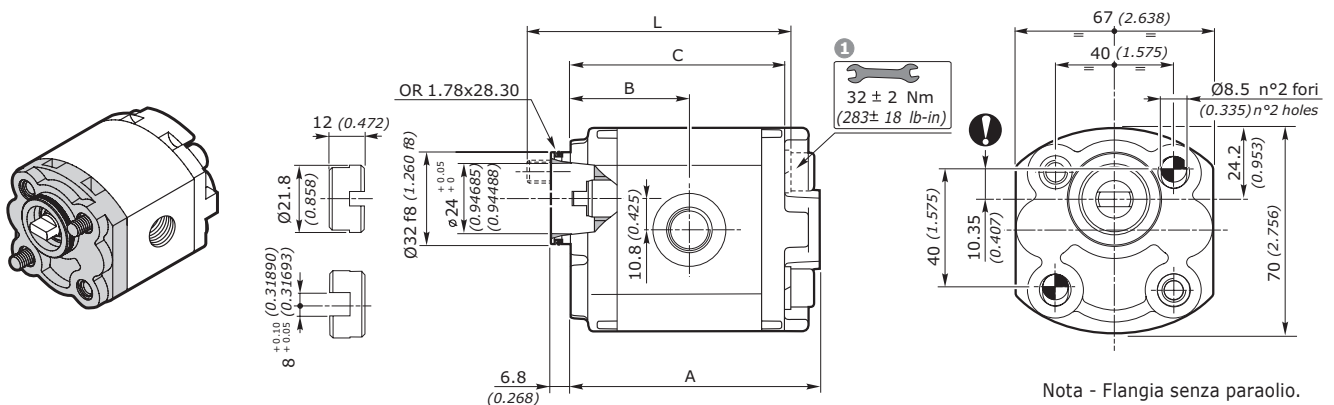

Nota - Flangia senza paraolio.  
Note - Flange without shaft seal.

1 Coppia di serraggio viti: 32 ± 2Nm (viti classe 10.9-12.9 UNI EN 20898/1)  
Il kit viti per il fissaggio della pompa è da ordinare separatamente.  
Codice di ordinazione: **0019W** (+ lunghezza L - vedi tabella)  
Il fissaggio della pompa può essere effettuato con 2 viti prigioniere (25 ± 2Nm).  
Fissare la pompa mediante dadi autobloccanti (32 ± 2 Nm).

1 Screw tightening torque: 283 ± 18 lb-in (screws 10.9-12.9 UNI EN 20898/1).  
The screw kit for the pump assembly should be ordered separately.  
Ordering code: **0019W** (+ length L - see table)  
The pump assembling should be made by 2 screws (221 ± 18 lb-in).  
Fix the pump by self-locking nuts (283 ± 18 lb-in).

GRUPPO - GROUP 1	A		B		C		L 1		MASSA - MASS	
	mm	inch	mm	inch	mm	inch	mm	inch	kg	lbs
<b>1SP 009</b>	73.6	2.898	34.80	1.370	61.6	2.425	80	3.150	0.91	2.01
<b>1SP 012</b>	74.7	2.941	35.35	1.392	62.7	2.469	80	3.150	0.93	2.05
<b>1SP 016</b>	76.4	3.008	36.20	1.425	64.4	2.535	80	3.150	0.95	2.09
<b>1SP 020</b>	77.9	3.067	36.95	1.455	65.9	2.594	80	3.150	0.97	2.14
<b>1SP 025</b>	79.9	3.146	37.95	1.494	67.9	2.673	85	3.346	1.00	2.21
<b>1SP 032</b>	82.6	3.252	39.30	1.547	70.6	2.780	85	3.346	1.04	2.29
<b>1SP 037</b>	84.6	3.331	40.30	1.587	72.6	2.858	90	3.543	1.07	2.36
<b>1SP 042</b>	86.5	3.406	41.25	1.624	74.5	2.933	90	3.543	1.10	2.43
<b>1SP 050</b>	89.6	3.528	42.80	1.685	77.6	3.055	95	3.740	1.14	2.51
<b>1SP 063</b>	94.7	3.728	45.35	1.785	82.7	3.256	100	3.937	1.22	2.69
<b>1SP 078</b>	100.4	3.953	48.20	1.898	88.4	3.480	105	4.134	1.30	2.87
<b>1SP 098</b>	108.3	4.264	52.15	2.053	96.3	3.791	115	4.528	1.41	3.11

**POMPE AD INGRANAGGI GRUPPO 1SP**  
**GEAR PUMPS GROUP 1SP**
**FLANGIA TEDESCA FISSAGGIO MINICENTRALINA CON ANELLO DI TENUTA**
**E32BC**
**POWER-PACK FIXING GERMAN FLANGE WITH SEAL SHAFT**

GRUPPO GROUP 1SP	CILINDRATA DISPLACEMENT		PRESSIONE MAX - MAX PRESSURE						VELOCITÀ MAX MAX SPEED	PORTATA MAX MAX FLOW		VELOCITÀ MIN MIN SPEED
	cm <sup>3</sup> /giro	in <sup>3</sup> /rev	P1		P2		P3			l/min	Gal/min	
			bar	psi	bar	psi	bar	psi	giri/min - rpm			giri/min - rpm
<b>1SP 009</b>	0.89	0.05	260	3770	280	4060	290	4205	6000	5.3	1.40	600
<b>1SP 012</b>	1.18	0.07	260	3770	280	4060	290	4205	6000	7.1	1.88	600
<b>1SP 016</b>	1.6	0.10	260	3770	280	4060	290	4205	6000	9.6	2.54	400
<b>1SP 020</b>	2.0	0.12	260	3770	280	4060	290	4205	5500	11	2.91	400
<b>1SP 025</b>	2.5	0.15	260	3770	280	4060	290	4205	5000	12.5	3.30	400
<b>1SP 032</b>	3.2	0.20	260	3770	280	4060	290	4205	4500	14.4	3.80	400
<b>1SP 037</b>	3.7	0.23	250	3625	270	3915	280	4060	4000	14.8	3.91	400
<b>1SP 042</b>	4.2	0.26	250	3625	270	3915	280	4060	3500	14.7	3.88	400
<b>1SP 050</b>	5.0	0.31	250	3625	270	3915	280	4060	3000	15	3.96	400
<b>1SP 063</b>	6.3	0.38	170	2465	190	2755	210	3045	2700	17	4.49	400
<b>1SP 078</b>	7.76	0.47	170	2465	190	2755	210	3045	2500	19.4	5.13	400
<b>1SP 098</b>	9.78	0.60	150	2175	170	2465	190	2755	2000	19.6	5.18	400

Nota - Per valori di pressione superiori a quelli indicati contattare il Servizio Commerciale.  
 Note - for higher pressure values please contact our Sales Dept.

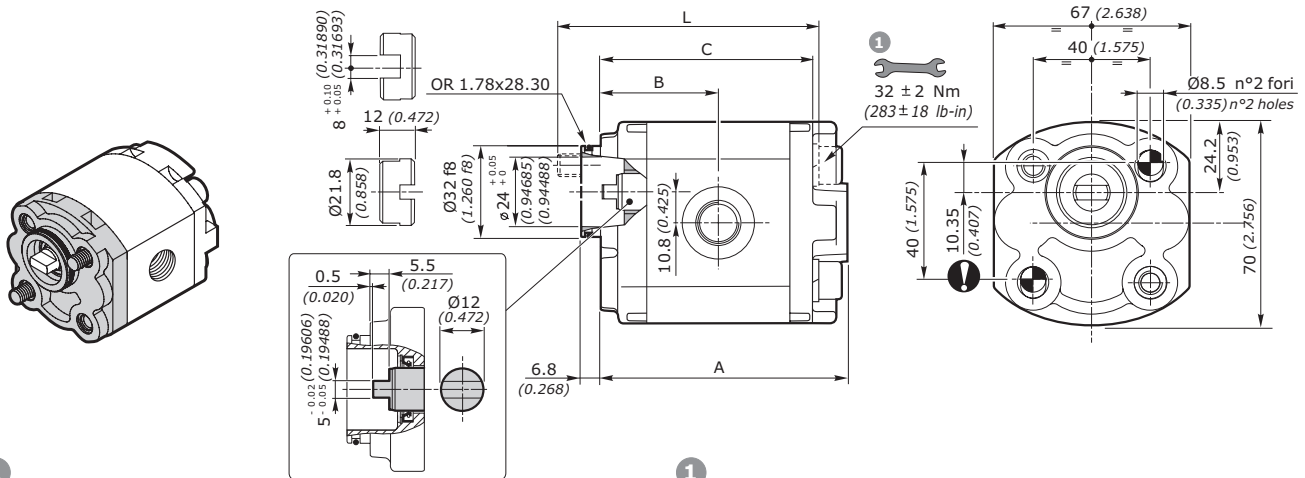
**DIMENSIONI • DIMENSIONS**

1 Coppia di serraggio viti: 32 ± 2Nm (viti classe 10.9-12.9 UNI EN 20898/1)  
 Il kit viti per il fissaggio della pompa è da ordinare separatamente.  
 Codice di ordinazione: **0019W** (+ lunghezza L - vedi tabella)

Il fissaggio della pompa può essere effettuato con 2 viti prigioniere (25 ± 2Nm).  
 Fissare la pompa mediante dadi autobloccanti (32 ± 2 Nm).

1 Screw tightening torque: 283 ± 18 lb-in (screws 10.9-12.9 UNI EN 20898/1).  
 The screw kit for the pump assembly should be ordered separately.  
 Ordering code: **0019W** (+ length L - see table)

The pump assembling should be made by 2 screws (221 ± 18 lb-in).  
 Fix the pump by self-locking nuts (283 ± 18 lb-in).

GRUPPO - GROUP 1	A		B		C		L 1		MASSA - MASS	
	mm	inch	mm	inch	mm	inch	mm	inch	kg	lbs
<b>1SP 009</b>	73.6	2.898	34.80	1.370	61.6	2.425	80	3.150	0.91	2.01
<b>1SP 012</b>	74.7	2.941	35.35	1.392	62.7	2.469	80	3.150	0.93	2.05
<b>1SP 016</b>	76.4	3.008	36.20	1.425	64.4	2.535	80	3.150	0.95	2.09
<b>1SP 020</b>	77.9	3.067	36.95	1.455	65.9	2.594	80	3.150	0.97	2.14
<b>1SP 025</b>	79.9	3.146	37.95	1.494	67.9	2.673	85	3.346	1.00	2.21
<b>1SP 032</b>	82.6	3.252	39.30	1.547	70.6	2.780	85	3.346	1.04	2.29
<b>1SP 037</b>	84.6	3.331	40.30	1.587	72.6	2.858	90	3.543	1.07	2.36
<b>1SP 042</b>	86.5	3.406	41.25	1.624	74.5	2.933	90	3.543	1.10	2.43
<b>1SP 050</b>	89.6	3.528	42.80	1.685	77.6	3.055	95	3.740	1.14	2.51
<b>1SP 063</b>	94.7	3.728	45.35	1.785	82.7	3.256	100	3.937	1.22	2.69
<b>1SP 078</b>	100.4	3.953	48.20	1.898	88.4	3.480	105	4.134	1.30	2.87
<b>1SP 098</b>	108.3	4.264	52.15	2.053	96.3	3.791	115	4.528	1.41	3.11



**POMPE AD INGRANAGGI GRUPPO 1SP**  
**GEAR PUMPS GROUP 1SP**

**FLANGIA PER ELETTROPOMPA E32CX ELECTRO-PUMP FLANGE**

GRUPPO GROUP 1SP	CILINDRATA DISPLACEMENT		PRESSIONE MAX - MAX PRESSURE						VELOCITÀ MAX MAX SPEED	PORTATA MAX MAX FLOW		VELOCITÀ MIN MIN SPEED
	cm <sup>3</sup> /giro	in <sup>3</sup> /rev	P1		P2		P3		giri/min - rpm	l/min	Gal/min	giri/min - rpm
			bar	psi	bar	psi	bar	psi				
1SP 009	0.89	0.05	260	3770	280	4060	290	4205	6000	5.3	1.40	600
1SP 012	1.18	0.07	260	3770	280	4060	290	4205	6000	7.1	1.88	600
1SP 016	1.6	0.10	260	3770	280	4060	290	4205	6000	9.6	2.54	400
1SP 020	2.0	0.12	260	3770	280	4060	290	4205	5500	11	2.91	400
1SP 025	2.5	0.15	260	3770	280	4060	290	4205	5000	12.5	3.30	400
1SP 032	3.2	0.20	260	3770	280	4060	290	4205	4500	14.4	3.80	400
1SP 037	3.7	0.23	250	3625	270	3915	280	4060	4000	14.8	3.91	400
1SP 042	4.2	0.26	250	3625	270	3915	280	4060	3500	14.7	3.88	400
1SP 050	5.0	0.31	250	3625	270	3915	280	4060	3000	15	3.96	400
1SP 063	6.3	0.38	170	2465	190	2755	210	3045	2700	17	4.49	400
1SP 078	7.76	0.47	170	2465	190	2755	210	3045	2500	19.4	5.13	400
1SP 098	9.78	0.60	150	2175	170	2465	190	2755	2000	19.6	5.18	400

Nota - Per valori di pressione superiori a quelli indicati contattare il Servizio Commerciale.  
Note - for higher pressure values please contact our Sales Dept.

**DIMENSIONI • DIMENSIONS**

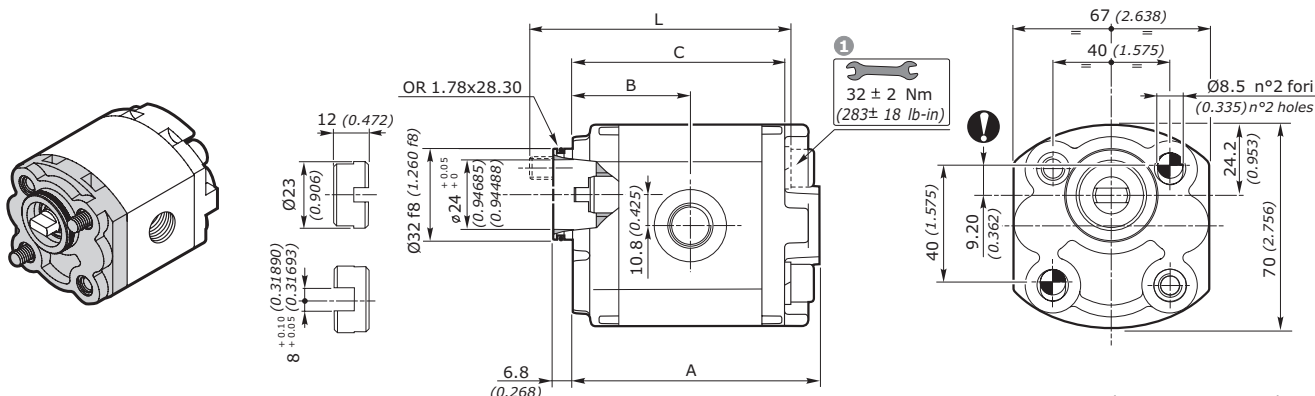

Nota - Flangia senza paraolio.  
Note - Flange without shaft seal.

1 Coppia di serraggio viti: 32 ± 2Nm (viti classe 10.9-12.9 UNI EN 20898/1)  
Il kit viti per il fissaggio della pompa è da ordinare separatamente.  
Codice di ordinazione: **0019W** (+ lunghezza L - vedi tabella)  
Il fissaggio della pompa può essere effettuato con 2 viti prigioniere (25 ± 2Nm).  
Fissare la pompa mediante dadi autobloccanti (32 ± 2 Nm).

1 Screw tightening torque: 283 ± 18 lb-in (screws 10.9-12.9 UNI EN 20898/1).  
The screw kit for the pump assembly should be ordered separately.  
Ordering code: **0019W** (+ length L - see table)  
The pump assembling should be made by 2 screws (221 ± 18 lb-in).  
Fix the pump by self-locking nuts (283 ± 18 lb-in).

GRUPPO - GROUP 1	A		B		C		L 1		MASSA - MASS	
	mm	inch	mm	inch	mm	inch	mm	inch	kg	lbs
1SP 009	73.6	2.898	34.80	1.370	61.6	2.425	80	3.150	0.91	2.01
1SP 012	74.7	2.941	35.35	1.392	62.7	2.469	80	3.150	0.93	2.05
1SP 016	76.4	3.008	36.20	1.425	64.4	2.535	80	3.150	0.95	2.09
1SP 020	77.9	3.067	36.95	1.455	65.9	2.594	80	3.150	0.97	2.14
1SP 025	79.9	3.146	37.95	1.494	67.9	2.673	85	3.346	1.00	2.21
1SP 032	82.6	3.252	39.30	1.547	70.6	2.780	85	3.346	1.04	2.29
1SP 037	84.6	3.331	40.30	1.587	72.6	2.858	90	3.543	1.07	2.36
1SP 042	86.5	3.406	41.25	1.624	74.5	2.933	90	3.543	1.10	2.43
1SP 050	89.6	3.528	42.80	1.685	77.6	3.055	95	3.740	1.14	2.51
1SP 063	94.7	3.728	45.35	1.785	82.7	3.256	100	3.937	1.22	2.69
1SP 078	100.4	3.953	48.20	1.898	88.4	3.480	105	4.134	1.30	2.87
1SP 098	108.3	4.264	52.15	2.053	96.3	3.791	115	4.528	1.41	3.11

**POMPE AD INGRANAGGI GRUPPO 1SP**  
**GEAR PUMPS GROUP 1SP**
**FLANGIA PER ELETTROPOMPA  
CON ANELLO DI TENUTA**
**E32CC**
**ELECTRO-PUMP FLANGE  
WITH SEAL SHAFT**

GRUPPO GROUP 1SP	CILINDRATA DISPLACEMENT		PRESSIONE MAX - MAX PRESSURE						VELOCITÀ MAX MAX SPEED	PORTATA MAX MAX FLOW		VELOCITÀ MIN MIN SPEED
	cm <sup>3</sup> /giro	in <sup>3</sup> /rev	P1		P2		P3			l/min	Gal/min	
			bar	psi	bar	psi	bar	psi	giri/min - rpm			giri/min - rpm
1SP 009	0.89	0.05	260	3770	280	4060	290	4205	6000	5.3	1.40	600
1SP 012	1.18	0.07	260	3770	280	4060	290	4205	6000	7.1	1.88	600
1SP 016	1.6	0.10	260	3770	280	4060	290	4205	6000	9.6	2.54	400
1SP 020	2.0	0.12	260	3770	280	4060	290	4205	5500	11	2.91	400
1SP 025	2.5	0.15	260	3770	280	4060	290	4205	5000	12.5	3.30	400
1SP 032	3.2	0.20	260	3770	280	4060	290	4205	4500	14.4	3.80	400
1SP 037	3.7	0.23	250	3625	270	3915	280	4060	4000	14.8	3.91	400
1SP 042	4.2	0.26	250	3625	270	3915	280	4060	3500	14.7	3.88	400
1SP 050	5.0	0.31	250	3625	270	3915	280	4060	3000	15	3.96	400
1SP 063	6.3	0.38	170	2465	190	2755	210	3045	2700	17	4.49	400
1SP 078	7.76	0.47	170	2465	190	2755	210	3045	2500	19.4	5.13	400
1SP 098	9.78	0.60	150	2175	170	2465	190	2755	2000	19.6	5.18	400

Nota - Per valori di pressione superiori a quelli indicati contattare il Servizio Commerciale.  
 Note - for higher pressure values please contact our Sales Dept.

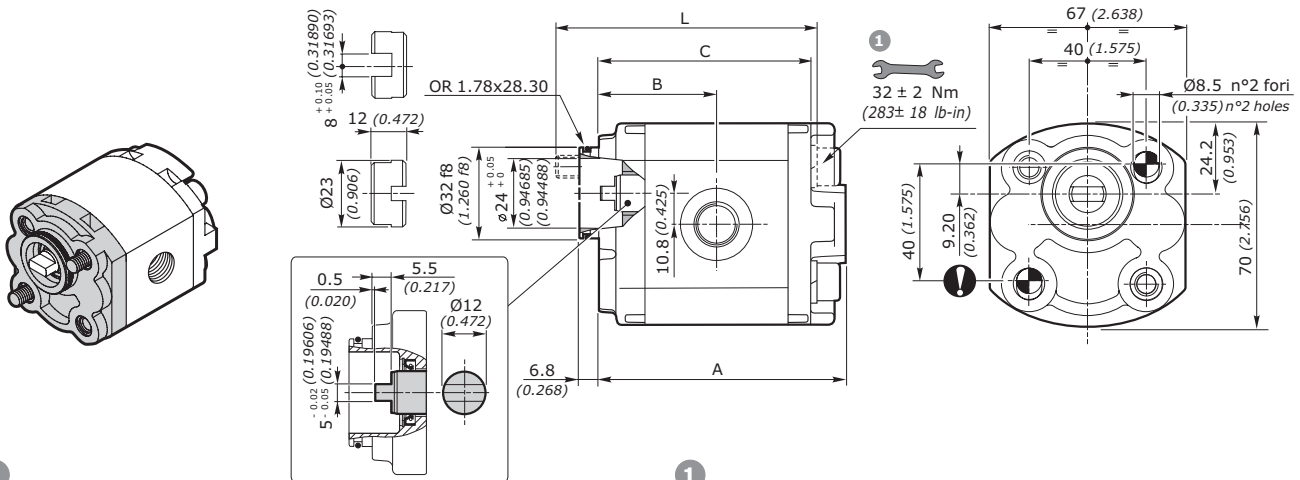
**DIMENSIONI • DIMENSIONS**

Coppia di serraggio viti: 32 ± 2Nm (viti classe 10.9-12.9 UNI EN 20898/1)  
 Il kit viti per il fissaggio della pompa è da ordinare separatamente.  
 Codice di ordinazione: **0019W** (+ lunghezza **L** - vedi tabella)

Il fissaggio della pompa può essere effettuato con 2 viti prigioniere (25 ± 2Nm).  
 Fissare la pompa mediante dadi autobloccanti (32 ± 2 Nm).

Screw tightening torque: 283 ± 18 lb-in (screws 10.9-12.9 UNI EN 20898/1).  
 The screw kit for the pump assembly should be ordered separately.  
 Ordering code: **0019W** (+ length **L** - see table)

The pump assembling should be made by 2 screws (221 ± 18 lb-in).  
 Fix the pump by self-locking nuts (283 ± 18 lb-in).

GRUPPO - GROUP 1	A		B		C		L 1		MASSA - MASS	
	mm	inch	mm	inch	mm	inch	mm	inch	kg	lbs
1SP 009	73.6	2.898	34.80	1.370	61.6	2.425	80	3.150	0.91	2.01
1SP 012	74.7	2.941	35.35	1.392	62.7	2.469	80	3.150	0.93	2.05
1SP 016	76.4	3.008	36.20	1.425	64.4	2.535	80	3.150	0.95	2.09
1SP 020	77.9	3.067	36.95	1.455	65.9	2.594	80	3.150	0.97	2.14
1SP 025	79.9	3.146	37.95	1.494	67.9	2.673	85	3.346	1.00	2.21
1SP 032	82.6	3.252	39.30	1.547	70.6	2.780	85	3.346	1.04	2.29
1SP 037	84.6	3.331	40.30	1.587	72.6	2.858	90	3.543	1.07	2.36
1SP 042	86.5	3.406	41.25	1.624	74.5	2.933	90	3.543	1.10	2.43
1SP 050	89.6	3.528	42.80	1.685	77.6	3.055	95	3.740	1.14	2.51
1SP 063	94.7	3.728	45.35	1.785	82.7	3.256	100	3.937	1.22	2.69
1SP 078	100.4	3.953	48.20	1.898	88.4	3.480	105	4.134	1.30	2.87
1SP 098	108.3	4.264	52.15	2.053	96.3	3.791	115	4.528	1.41	3.11

**POMPE AD INGRANAGGI GRUPPO 1SP**  
**GEAR PUMPS GROUP 1SP**
**CODICE ORDINAZIONE • ORDER CODE**
**1SP - A - 020 - D - EUR - B - N - 10 - 0 - G**

SIGLA - CODE	TIPO - TYPE	DESCRIZIONE - DESCRIPTION	PAGINA - PAGE
<b>1SP</b>	Tipo pompa <i>Pump type</i>	Pompa singola - gruppo 1 <i>Single pump - group 1</i>	4
<b>A</b>	Materiale flangia e coperchio <i>Flange and cover material</i>	<b>A</b> = alluminio / <i>aluminium</i>	
<b>020</b>	Cilindrata <i>Displacement</i>	Cilindrata = 2 cm <sup>3</sup> /giro <i>Displacement = 0.12 in<sup>3</sup>/rev</i>	4
<b>D</b>	Senso di rotazione <i>Rotation wise</i>	<b>D</b> = Rotazione destra / <i>Clockwise rotation</i> <b>S</b> = Rotazione sinistra / <i>Anticlockwise rotation</i> <b>R</b> = Reversibile / <i>Reversible</i>	8
<b>EUR</b>	Tipo Flangia <i>Flange type</i>	Flangia europea standard <i>Standard European flange</i>	26
<b>B</b>	Tipo anello di tenuta <i>Seal ring type</i>	Vedi tabella compatibilità <i>See compatibility table</i>	
<b>N</b>	Tipo guarnizione <i>Gasket type</i>	<b>N</b> = NBR <b>V</b> = Viton	27
<b>10</b>	Tipo Albero <i>Shaft type</i>	Vedi tabella compatibilità <i>See compatibility table</i>	
<b>0</b>	Posizione connessione <i>Connection position</i>	Vedi tabella compatibilità <i>See compatibility table</i>	30
<b>G</b>	Tipo connessione <i>Connection type</i>	Vedi tabella compatibilità <i>See compatibility table</i>	

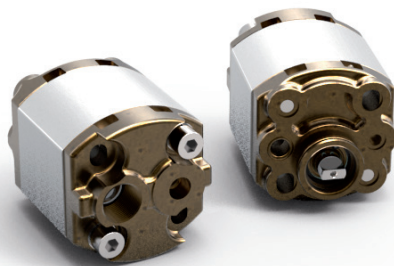

**POMPE AD INGRANAGGI GRUPPO 1SP**  
**GEAR PUMPS GROUP 1SP**
**TIPOLOGIA FLANGIA • FLANGE TYPE**

	EUR	SAEAA	MC32	E32BX - E32BC	E32CX - E32CC
<b>1SP</b>					
<b>A</b> alluminio-aluminium	◇	◇	◇	◇	◇
<b>G</b> ghisa-cast iron	non disponibile not available	non disponibile not available	non disponibile not available	non disponibile not available	non disponibile not available

◇ = Combinazione standard - Standard combination

**ANELLO DI TENUTA • SEAL RING**

SIGLA - CODE	TIPO - TYPE	DIAGRAMMA - DIAGRAM
<b>A</b>	Flangia senza anello di tenuta Flange without seal ring	/
<b>B</b>	Anello di tenuta fino a <b>3</b> bar Sealing ring up to <b>3</b> bar	
<b>H</b>	Anello di tenuta fino a <b>8</b> bar Sealing ring up to <b>8</b> bar	
<b>K</b>	Anello di tenuta fino a <b>30</b> bar Sealing ring up to <b>30</b> bar	

**POMPE AD INGRANAGGI GRUPPO 1SP**  
**GEAR PUMPS GROUP 1SP**

**COMBINAZIONE FLANGIA - ANELLO DI TENUTA - GUARNIZIONE • FLANGE - SEAL RING - GASKET COMBINATION**

1SP	EUR			SAEAA			MC32			E32BX			E32BC			E32CX			E32CC		
	Anello - seal ring			Anello - seal ring			Anello - seal ring			Anello - seal ring			Anello - seal ring			Anello - seal ring			Anello - seal ring		
	B	H	K	B	H	K	B	H	K	A	B	K	A	B	K	A	B	K			
NBR <b>N</b>	◊	◊	◊	◊	◊	◊	◊	◊	◊	◊	◊	●	◊	◊	●	◊	◊	●			
Viton <b>V</b>	●	●	●	●	●	●	●	●	●	●	●	●	●	●	●	●	●	●			

esempio • example: **1SP - A - 020 - D - EUR - B - N - 10 - 0 - G**

**EUR** = Flangia europea / European flange

**B** = Anello tenuta fino a 3 bar / Seal ring up to 3 bar

**N** = Guarnizione in NBR / NBR o-ring

**COMBINAZIONE ALBERO - FLANGIA • SHAFT - FLANGE COMBINATION**

1SP	EUR	SAEAA	MC32	E32BX-E32BC	E32CX-E32CC
<b>10</b> Conico 1:8 Tapered 1:8	◊	●	●		
<b>11</b> Conico 1:5 Tapered 1:5	●	●	●		
<b>13</b> Cilindrico SAEAA Parallel shaft SAEAA	●	◊			
<b>14</b> Scanalato SAEAA 9T SAEAA 9T splined	●	◊			
<b>15</b> Scanalato DIN 5480 6T 12x9 DIN 5480 Splined	●	●	●		
<b>17</b> Fresato a dente frontale Dihedral claw				◊	◊
<b>27</b> Fresato a dente frontale (con anello) Dihedral claw (with sealing ring)	●	●	◊		

◊ = Combinazione standard - Standard combination

● = Combinazione disponibile - Available combination

**POMPE AD INGRANAGGI GRUPPO 1SP**  
**GEAR PUMPS GROUP 1SP**
**1SP**

## DIMENSIONI ALBERO - SHAFT DIMENSIONS

<p><b>10</b> Conico 1:8 Tapered 1:8</p> <p>Coppia 30 Nm Torque 22 ft-lbs</p>	<p>Disponibile per - available for: <b>EUR - MC32</b></p>	<p>Disponibile per - available for: <b>SAEAA</b></p>
<p><b>11</b> Conico 1:5 Tapered 1:5</p> <p>Coppia 30 Nm Torque 22 ft-lbs</p>	<p>Disponibile per - available for: <b>EUR - MC32</b></p>	<p>Disponibile per - available for: <b>SAEAA</b></p>
<p><b>13</b> Cilindrico SAEAA Parallel shaft SAEAA</p> <p>Coppia 35 Nm Torque 26 ft-lbs</p>	<p>Disponibile per - available for: <b>EUR</b></p>	<p>Disponibile per - available for: <b>SAEAA</b></p>
<p><b>14</b> Scanalato SAEAA 9T SAEAA 9T splined</p> <p>Coppia 40 Nm Torque 30 ft-lbs</p>	<p>Profilo scanalato SAE 9T - 20/40 DP</p> <p>Splined profile SAE 9T - 20/40 DP</p> <p>Disponibile per - available for: <b>EUR</b></p>	<p>Profilo scanalato SAE 9T - 20/40 DP</p> <p>Splined profile SAE 9T - 20/40 DP</p> <p>Disponibile per - available for: <b>SAEAA</b></p>
<p><b>15</b> Scanalato DIN 5480 6T 12x9 DIN 5480 splined</p> <p>Coppia 30 Nm Torque 22 ft-lbs</p>	<p>Profilo scanalato DIN 5480 12x9 Z=6</p> <p>Splined profile DIN 5480 12x9 z=6</p> <p>Disponibile per - available for: <b>EUR - MC32</b></p>	<p>Profilo scanalato DIN 5480 12x9 Z=6</p> <p>Splined profile DIN 5480 12x9 z=6</p> <p>Disponibile per - available for: <b>SAEAA</b></p>

**POMPE AD INGRANAGGI GRUPPO 1SP**  
**GEAR PUMPS GROUP 1SP**

**1SP**

DIMENSIONI ALBERO - SHAFT DIMENSIONS

**17**  
 Fresato  
 a dente frontale  
 Dihedral claw

Coppia 25 Nm  
 Torque 19 ft-lbs

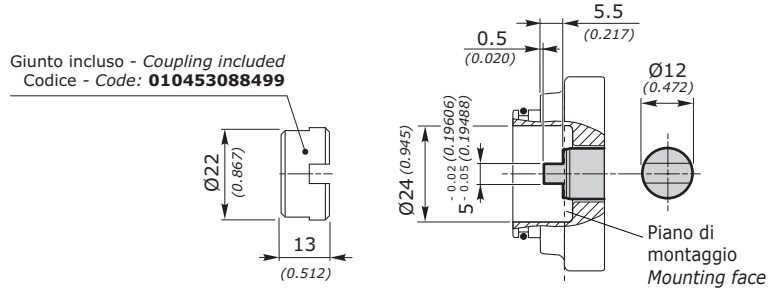

**27**  
 Fresato  
 a dente frontale  
 (con anello)  
 Dihedral claw  
 (with sealing ring)

Coppia 25 Nm  
 Torque 19 ft-lbs

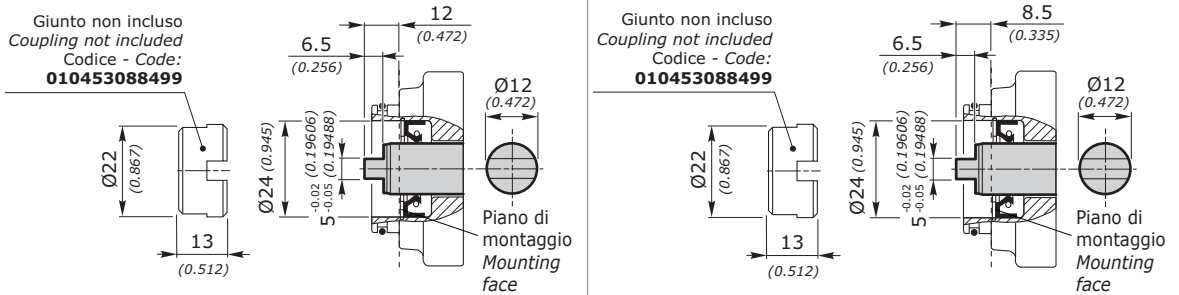

**POSIZIONE CONNESSIONE • CONNECTION POSITION**

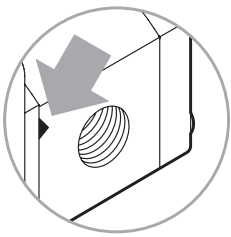
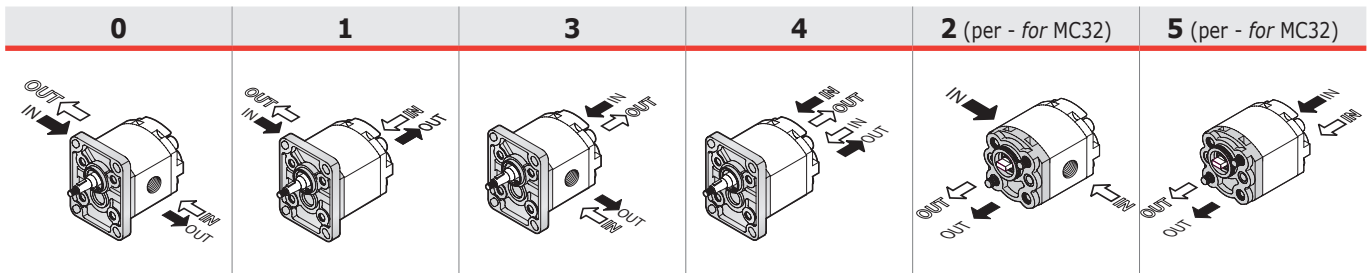
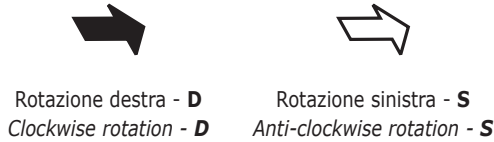

Il segno del corpo indica il lato aspirazione per le pompe  
 The sign on the body identifies the suction side for the pumps

**IN = ASPIRAZIONE - SUCTION**  
**OUT = MANDATA - DELIVERY**

**POMPE AD INGRANAGGI GRUPPO 1SP**  
**GEAR PUMPS GROUP 1SP**
**COPERCHIO STANDARD • STANDARD COVER**

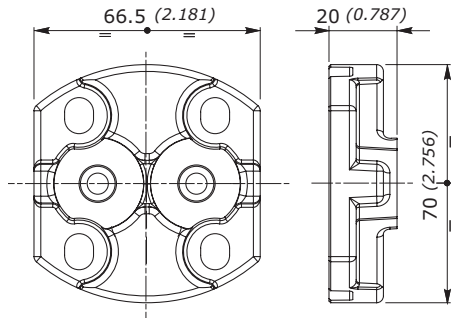
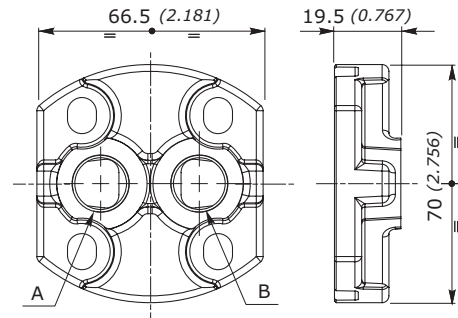
 Per posizioni **0 e 2**  
 For position **0 and 2**

 Per posizioni **1, 3, 4 e 5**  
 For position **1, 3, 4 e 5**

CONNESSIONI / CONNECTION		
	A	B
<b>GAS</b>	G 3/8	G 3/8
<b>SAE</b>	SAE 6	SAE 6

**TIPO CONNESSIONE • CONNECTION TYPE**

Le connessioni rappresentate corrispondono alle versioni standard; per connessioni differenti, contattare il nostro Ufficio Commerciale.

The connection types shown correspond to standard configurations; for different applications contact our Commercial Dept.

<b>1SP</b>		POSIZIONE CONNESSIONE - CONNECTION POSITION					
		<b>0</b>	<b>1</b>	<b>3</b>	<b>4</b>	<b>2</b>	<b>5</b>
GAS	<b>G</b>	◇	◇	◇	◇	◇	◇
UNF	<b>U</b>	◇	◇	◇	◇	◇	◇
FLANGIATE	<b>T</b>	◇				◇	
FLANGED	<b>N</b>	◇				◇	

<b>GAS</b>	UNI ISO 228/1	SIGLA CODE	CIL. DISPL.	ASPIRAZIONE - SUCTION IN			MANDATA - DELIVERY OUT		
				A	B	↻	A	B	↻
		<b>G</b>	009	G 3/8"	14 [mm] 0.552 [inch]	40 [Nm] 354 [in.lbs]	G 3/8"	14 [mm] 0.552 [inch]	40 [Nm] 354 [in.lbs]
			012						
			016						
			020						
			025						
			032						
			037						
			042						
			050						
			063						
			078						
			098						



**POMPE AD INGRANAGGI GRUPPO 1SP**  
**GEAR PUMPS GROUP 1SP**

UNF	ANSI/ASME B1.1	SIGLA CODE	CIL. DISPL.	ASPIRAZIONE - SUCTION IN			MANDATA - DELIVERY OUT		
				A	B		A	B	
		<b>U</b>	009	SAE 6 9/16"-18 UNF	13 [mm] 0.512 [inch]	40 [Nm] 354 [in.lbs]	SAE 6 9/16"-18 UNF	13 [mm] 0.512 [inch]	40 [Nm] 354 [in.lbs]
			012						
			016						
			020						
			025	SAE 8 3/4"-14 UNF	15 [mm] 0.591 [inch]	50 [Nm] 443 [in.lbs]	SAE 8 3/4"-14 UNF	15 [mm] 0.591 [inch]	50 [Nm] 443 [in.lbs]
			032						
			037						
			042						
			050						
			063						
			078						
			098						

FLANGIATE FLANGED	ISO/R 262	SIGLA CODE	CIL. DISPL.	ASPIRAZIONE - SUCTION IN					MANDATA - DELIVERY OUT				
				A	B	C	D		A	B	C	D	
		<b>T</b>	009	12 [mm] 0.472 [inch]	30 [mm] 1.181 [inch]	M6	13 [mm] 0.512 [inch]	8 [Nm] 71 [in.lbs]	12 [mm] 0.472 [inch]	30 [mm] 1.181 [inch]	M6	13 [mm] 0.512 [inch]	8 [Nm] 71 [in.lbs]
			012										
			016										
			020										
			025										
			032										
			037										
			042										
			050										
			063										
078													
098													
		<b>N</b>	009	10 [mm] 0.394 [inch]	26 [mm] 1.024 [inch]	M5	11 [mm] 0.433 [inch]	7 [Nm] 62 [in.lbs]	10 [mm] 0.394 [inch]	26 [mm] 1.024 [inch]	M5	11 [mm] 0.433 [inch]	7 [Nm] 62 [in.lbs]
			012										
			016										
			020										
			025	13 [mm] 0.512 [inch]	30 [mm] 1.181 [inch]	M6	11 [mm] 0.433 [inch]	8 [Nm] 71 [in.lbs]	13 [mm] 0.512 [inch]	30 [mm] 1.181 [inch]	M6	11 [mm] 0.433 [inch]	8 [Nm] 71 [in.lbs]
			032										
			037										
			042										
			050										
			063										
078													
098													

**POMPE AD INGRANAGGI GRUPPO 1SP**  
**GEAR PUMPS GROUP 1SP**
**OPZIONI • OPTIONS**
**VLPI**

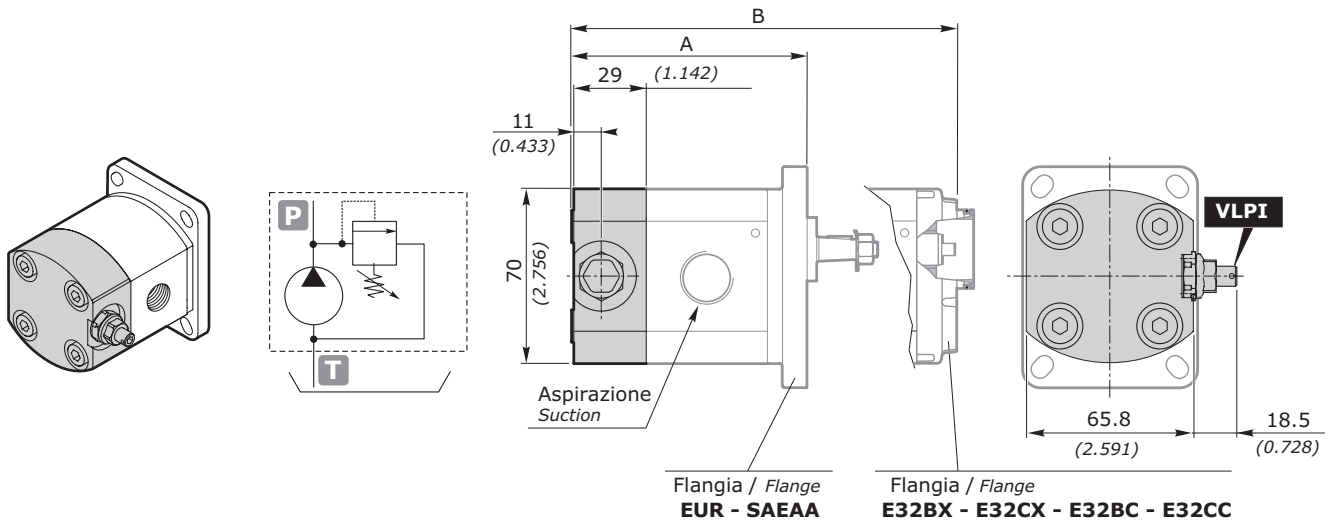
 VALVOLA LIMITATRICE DI PRESSIONE A SCARICO INTERNO  
 PRESSURE RELIEF VALVE WITH INTERNAL EXHAUST

GRUPPO GROUP 1	A		A		B	
	EUR		SAEAA		E32BX - E32CX E32BC - E32CC	
	mm	inch	mm	inch	mm	inch
1SP 009	82.6	3.252	86.1	3.390	82.6	3.252
1SP 012	83.7	3.295	87.2	3.433	83.7	3.295
1SP 016	85.4	3.362	88.9	3.500	85.4	3.362
1SP 020	86.9	3.421	90.4	3.559	86.9	3.421
1SP 025	88.9	3.500	92.4	3.638	88.9	3.500
1SP 032	91.6	3.606	95.1	3.744	91.6	3.606
1SP 037	93.6	3.685	97.1	3.823	93.6	3.685
1SP 042	95.5	3.760	99.0	3.898	95.5	3.760
1SP 050	98.6	3.882	102.1	4.020	98.6	3.882
1SP 063	103.7	4.083	107.2	4.220	103.7	4.083
1SP 078	109.4	4.307	112.9	4.445	109.4	4.307
1SP 098	117.3	4.618	120.8	4.756	117.3	4.618

**ATTENZIONE:**

La valvola limitatrice di pressione si applica sostituendo il coperchio posteriore (previsto solo scarico interno). Il corpo VLP è disponibile in alluminio.

**L'apertura della valvola limitatrice di pressione deve avvenire per tempi non superiori ai 10 secondi ogni minuto, per evitare il surriscaldamento della pompa.**

**WARNING:**

The pressure relief valve can be applied by substituting the rear cover (only internal relief is set). VLP cover is available in aluminum.

**The opening of the pressure relief valve should be carried out for times not over 10" each minute, to avoid the overheating of the pump.**

 esempio • example: **1SP - A - 020 - D - EUR - B - N - 10 - 0 - G - VLPI (N 120)**
**VLPI** = Coperchio con VPL a scarico interno / Cover with VPL with internal exhaust

**N** = Tipo molla - vedi tabella / Spring type - see table

**120** = Taratura - vedi tabella / Setting - see table

TIPO - TYPE	CAMPI DI TARATURE - CALIBRATION FIELDS					
	molla bianca - white spring	B	molla nera - black spring	N	molla rossa - red spring	R
bar	30 ÷ 80		81 ÷ 200		201 ÷ 350	
psi	435 ÷ 1160		1175 ÷ 2900		2915 ÷ 5075	
STANDARD	70 bar (1015 psi)		150 bar (2175 psi)		250 bar (3625 psi)	

NOTA: In caso di omissione del valore di taratura, esso sarà inteso standard (vedi tabella).

NOTE: Without setting request, it will be considered standard (see table).

**POMPE AD INGRANAGGI GRUPPO 1SP**  
**GEAR PUMPS GROUP 1SP**

**VLPE**

VALVOLA LIMITATRICE DI PRESSIONE A SCARICO ESTERNO  
PRESSURE RELIEF VALVE WITH EXTERNAL EXHAUST

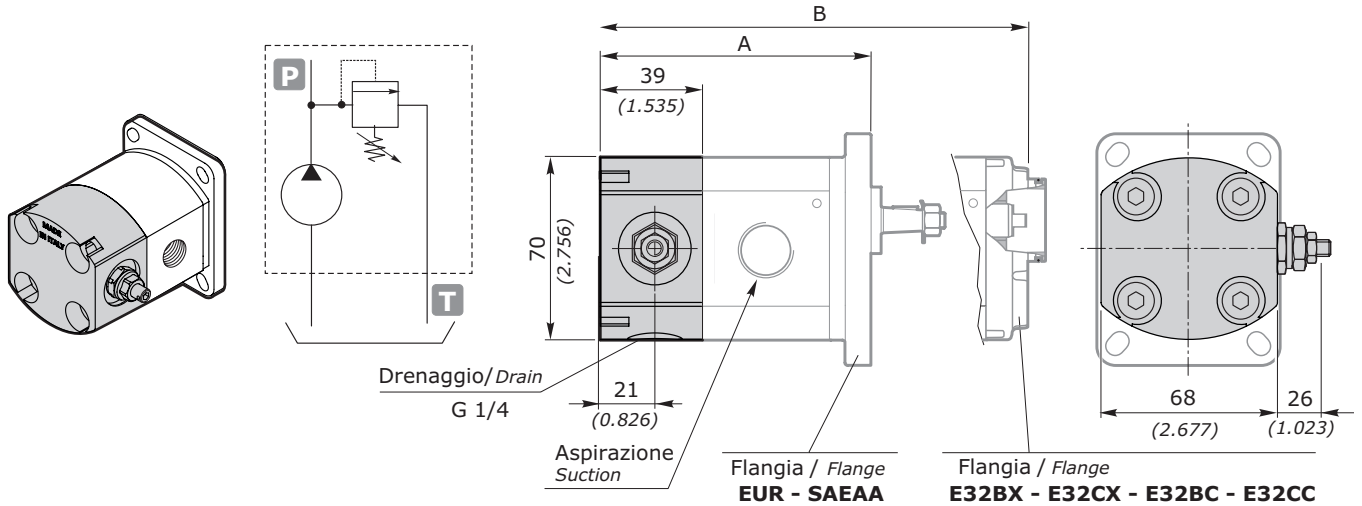

GRUPPO GROUP 1	A		A		B	
	EUR	inch	SAEAA	inch	E32BX - E32CX E32BC - E32CC	inch
1SP 009	92.6	3.645	96.1	3.783	92.6	3.645
1SP 012	93.7	3.688	97.2	3.826	93.7	3.688
1SP 016	95.4	3.755	98.9	3.893	95.4	3.755
1SP 020	96.9	3.814	100.4	3.952	96.9	3.814
1SP 025	98.9	3.893	102.4	4.031	98.9	3.893
1SP 032	101.6	4	105.1	4.137	101.6	4
1SP 037	103.6	4.078	107.1	4.216	103.6	4.078
1SP 042	105.5	4.153	109.0	4.291	105.5	4.153
1SP 050	108.6	4.275	112.1	4.413	108.6	4.275
1SP 063	113.7	4.476	117.2	4.614	113.7	4.476
1SP 078	119.4	4.7	122.9	4.838	119.4	4.7
1SP 098	127.3	5.011	130.8	5.149	127.3	5.011

La valvola limitatrice di pressione si applica sostituendo il coperchio posteriore. Il coperchio VLP è disponibile in alluminio. E' rappresentata una pompa con rotazione destra. Nelle pompe con rotazione sinistra, la valvola è dal lato opposto

*The pressure relief valve can be applied by substituting the rear cover. VLP cover is available in aluminum. The showed pump is with clockwise rotation. In the case of pumps with anticlockwise rotation, the valve is on the opposite side.*

esempio • example: **1SP - A - 020 - D - EUR - B - N - 10 - 0 - G - VLPE (N 120)**

**VLPE** = Coperchio con VPL a scarico esterno / Cover with VPL with external exhaust

**N** = Tipo molla - vedi tabella / Spring type - see table

**120** = Taratura - vedi tabella / Setting - see table

TIPO - TYPE	CAMPI DI TARATURE - CALIBRATION FIELDS					
	molla bianca - white spring	B	molla nera - black spring	N	molla rossa - red spring	R
bar	30 ÷ 80		81 ÷ 200		201 ÷ 350	
psi	435 ÷ 1160		1175 ÷ 2900		2915 ÷ 5075	
STANDARD	70 bar (1015 psi)		150 bar (2175 psi)		250 bar (3625 psi)	

NOTA: In caso di omissione del valore di taratura, esso sarà inteso standard (vedi tabella).

NOTE: Without setting request, it will be considered standard (see table).

**POMPE AD INGRANAGGI GRUPPO 2SP**  
**GEAR PUMPS GROUP 2SP**
**FLANGIA EUROPEA EUR EUROPEAN FLANGE**
**FLANGIA E COPERCHIO IN ALLUMINIO - FLANGE AND COVER IN ALUMINIUM**

GRUPPO GROUP 2SP	CILINDRATA DISPLACEMENT		PRESSIONE MAX - MAX PRESSURE						VELOCITÀ MAX MAX SPEED	PORTATA MAX MAX FLOW		VELOCITÀ MIN MIN SPEED
			P1		P2		P3					
	cm <sup>3</sup> /giro	in <sup>3</sup> /rev	bar	psi	bar	psi	bar	psi	giri/min - rpm	l/min	Gal/min	giri/min - rpm
<b>2SP 040</b>	4	0.24	250	3625	270	3915	290	4205	4000	16	4.23	500
<b>2SP 060</b>	6	0.37	250	3625	270	3915	290	4205	4000	24	6.34	500
<b>2SP 080</b>	8.5	0.52	250	3625	270	3915	290	4205	3500	29.7	7.85	500
<b>2SP 110</b>	11	0.67	250	3625	270	3915	290	4205	3500	38.5	10.17	500
<b>2SP 140</b>	14	0.85	250	3625	270	3915	290	4205	3500	49	12.95	500
<b>2SP 160</b>	16.5	1.01	230	3335	240	3480	250	3625	3500	57.7	15.24	500
<b>2SP 190</b>	19.5	1.19	210	3045	220	3190	230	3335	3300	64.3	16.99	500
<b>2SP 220</b>	22.5	1.37	190	2755	200	2900	210	3045	2800	63	16.64	500
<b>2SP 260</b>	26	1.59	170	2465	180	2610	190	2755	2500	65	17.17	500
<b>2SP 310</b>	31.5	1.92	130	1885	140	2030	150	2175	2200	69	18.22	500

Nota - Per valori di pressione superiori a quelli indicati contattare il Servizio Commerciale.  
 Note - for higher pressure values please contact our Sales Dpt.

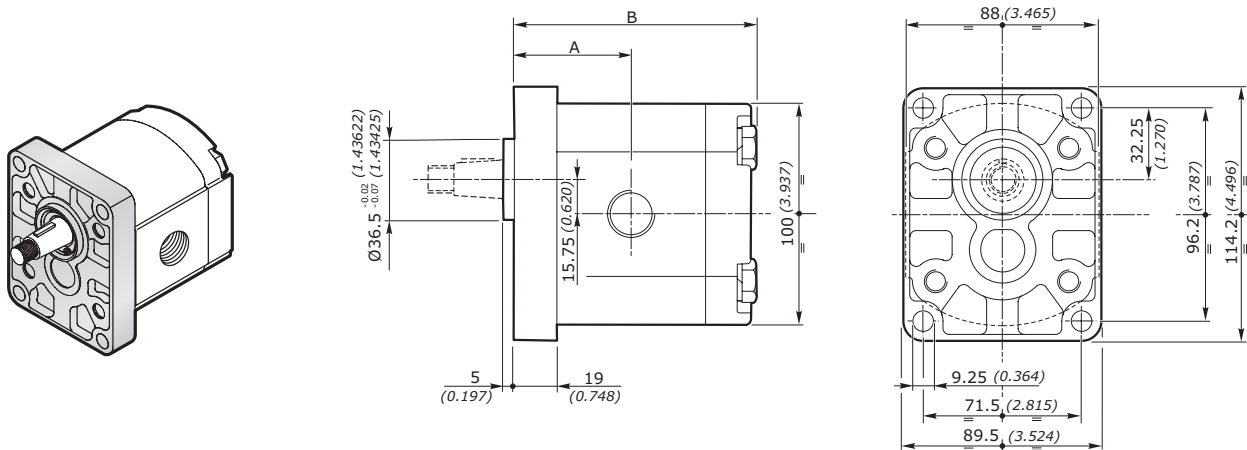
**DIMENSIONI • DIMENSIONS**

GRUPPO - GROUP 2	A		B		MASSA - MASS	
	mm	inch	mm	inch	kg	lbs
<b>2SP 040</b>	44.4	1.748	93.0	3.661	2.30	5.07
<b>2SP 060</b>	46.0	1.811	96.3	3.791	2.45	5.40
<b>2SP 080</b>	48.1	1.894	100.5	3.957	2.60	5.73
<b>2SP 110</b>	50.2	1.976	104.6	4.118	2.70	5.95
<b>2SP 140</b>	52.7	2.075	109.6	4.315	2.80	6.17
<b>2SP 160</b>	54.8	2.157	113.8	4.480	2.95	6.51
<b>2SP 190</b>	57.3	2.256	118.8	4.677	3.10	6.84
<b>2SP 220</b>	59.8	2.354	123.8	4.874	3.25	7.17
<b>2SP 260</b>	62.7	2.469	129.6	5.102	3.40	7.50
<b>2SP 310</b>	66.9	2.636	138.0	5.437	3.61	7.96

**POMPE AD INGRANAGGI GRUPPO 2SP**  
**GEAR PUMPS GROUP 2SP**

**FLANGIA EUROPEA EUR EUROPEAN FLANGE**

**FLANGIA E COPERCHIO IN GHISA - FLANGE AND COVER IN CAST IRON**

GRUPPO GROUP 2SP	CILINDRATA DISPLACEMENT		PRESSIONE MAX - MAX PRESSURE						VELOCITÀ MAX MAX SPEED	PORTATA MAX MAX FLOW		VELOCITÀ MIN MIN SPEED
			P1		P2		P3					
	cm³/giro	in³/rev	bar	psi	bar	psi	bar	psi	giri/min - rpm	l/min	Gal/min	giri/min - rpm
<b>2SP 040</b>	4	0.24	260	3770	280	4060	300	4350	4000	16	4.23	500
<b>2SP 060</b>	6	0.37	260	3770	280	4060	300	4350	4000	24	6.34	500
<b>2SP 080</b>	8.5	0.52	260	3770	280	4060	300	4350	3500	29.7	7.85	500
<b>2SP 110</b>	11	0.67	260	3770	280	4060	300	4350	3500	38.5	10.17	500
<b>2SP 140</b>	14	0.85	260	3770	280	4060	300	4350	3500	49	12.95	500
<b>2SP 160</b>	16.5	1.01	240	3480	250	3625	260	3770	3500	57.7	15.24	500
<b>2SP 190</b>	19.5	1.19	220	3190	230	3335	240	3480	3300	64.3	16.99	500
<b>2SP 220</b>	22.5	1.37	200	2900	210	3045	220	3190	2800	63	16.64	500
<b>2SP 260</b>	26	1.59	180	2610	190	2755	200	2900	2500	65	17.17	500
<b>2SP 310</b>	31.5	1.92	140	2030	150	2175	160	2320	2200	69	18.22	500

Nota - Per valori di pressione superiori a quelli indicati contattare il Servizio Commerciale.  
 Note - for higher pressure values please contact our Sales Dpt.

**DIMENSIONI • DIMENSIONS**

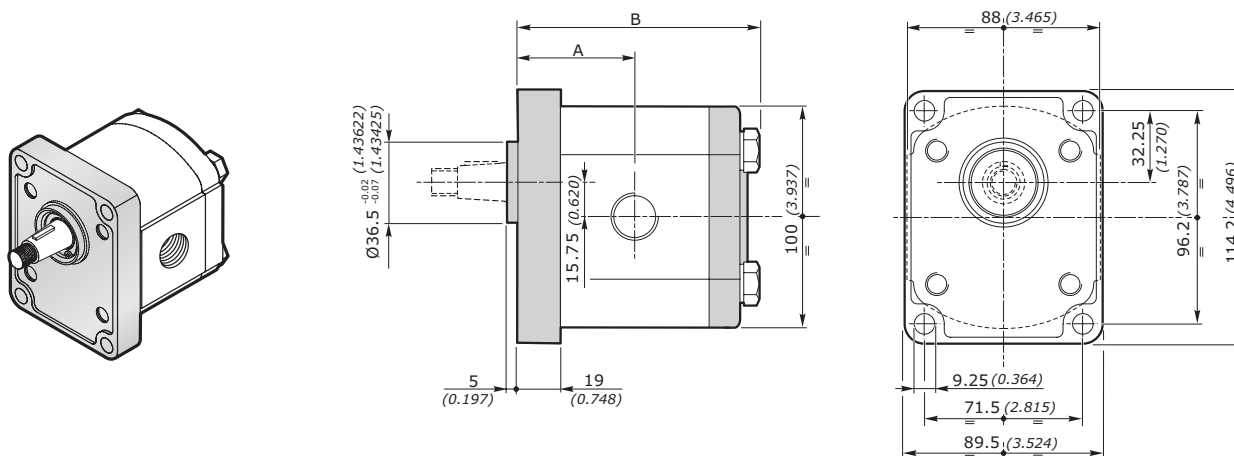

GRUPPO - GROUP 2	A		B		MASSA - MASS	
	mm	inch	mm	inch	kg	lbs
<b>2SP 040</b>	44.4	1.748	93.0	3.661	3.40	7.50
<b>2SP 060</b>	46.0	1.811	96.3	3.791	3.55	7.83
<b>2SP 080</b>	48.1	1.894	100.5	3.957	3.70	8.16
<b>2SP 110</b>	50.2	1.976	104.6	4.118	3.80	8.38
<b>2SP 140</b>	52.7	2.075	109.6	4.315	3.90	8.60
<b>2SP 160</b>	54.8	2.157	113.8	4.480	4.05	8.93
<b>2SP 190</b>	57.3	2.256	118.8	4.677	4.20	9.26
<b>2SP 220</b>	59.8	2.354	123.8	4.874	4.35	9.59
<b>2SP 260</b>	62.7	2.469	129.6	5.102	4.50	9.92
<b>2SP 310</b>	66.9	2.636	138.0	5.437	4.71	7.96

**POMPE AD INGRANAGGI GRUPPO 2SP**  
**GEAR PUMPS GROUP 2SP**
**FLANGIA SAE SAEA-SAEAOR SAE FLANGE**
**FLANGIA E COPERCHIO IN ALLUMINIO - FLANGE AND COVER IN ALUMINIUM**

GRUPPO GROUP 2SP	CILINDRATA DISPLACEMENT		PRESSIONE MAX - MAX PRESSURE						VELOCITÀ MAX MAX SPEED	PORTATA MAX MAX FLOW		VELOCITÀ MIN MIN SPEED
	cm³/giro	in³/rev	P1		P2		P3			l/min	Gal/min	
			bar	psi	bar	psi	bar	psi	giri/min - rpm			giri/min - rpm
<b>2SP 040</b>	4	0.24	250	3625	270	3915	290	4205	4000	16	4.23	500
<b>2SP 060</b>	6	0.37	250	3625	270	3915	290	4205	4000	24	6.34	500
<b>2SP 080</b>	8.5	0.52	250	3625	270	3915	290	4205	3500	29.7	7.85	500
<b>2SP 110</b>	11	0.67	250	3625	270	3915	290	4205	3500	38.5	10.17	500
<b>2SP 140</b>	14	0.85	250	3625	270	3915	290	4205	3500	49	12.95	500
<b>2SP 160</b>	16.5	1.01	230	3335	240	3480	250	3625	3500	57.7	15.24	500
<b>2SP 190</b>	19.5	1.19	210	3045	220	3190	230	3335	3300	64.3	16.99	500
<b>2SP 220</b>	22.5	1.37	190	2755	200	2900	210	3045	2800	63	16.64	500
<b>2SP 260</b>	26	1.59	170	2465	180	2610	190	2755	2500	65	17.17	500
<b>2SP 310</b>	31.5	1.92	130	1885	140	2030	150	2175	2200	69	18.22	500

Nota - Per valori di pressione superiori a quelli indicati contattare il Servizio Commerciale.  
 Note - for higher pressure values please contact our Sales Dpt.

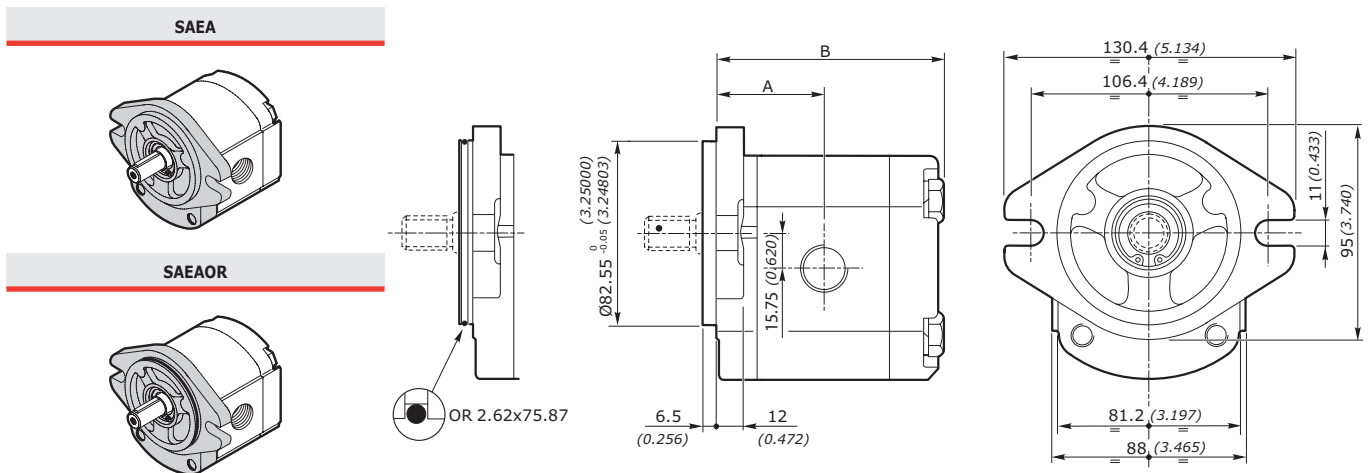
**DIMENSIONI • DIMENSIONS**

GRUPPO - GROUP 2	A		B		MASSA - MASS	
	mm	inch	mm	inch	kg	lbs
<b>2SP 040</b>	44.4	1.748	93.0	3.661	2.30	5.07
<b>2SP 060</b>	46.0	1.811	96.3	3.791	2.45	5.40
<b>2SP 080</b>	48.1	1.894	100.5	3.957	2.60	5.73
<b>2SP 110</b>	50.2	1.976	104.6	4.118	2.70	5.95
<b>2SP 140</b>	52.7	2.075	109.6	4.315	2.80	6.17
<b>2SP 160</b>	54.8	2.157	113.8	4.480	2.95	6.51
<b>2SP 190</b>	57.3	2.256	118.8	4.677	3.10	6.84
<b>2SP 220</b>	59.8	2.354	123.8	4.874	3.25	7.17
<b>2SP 260</b>	62.7	2.469	129.6	5.102	3.40	7.50
<b>2SP 310</b>	66.9	2.636	138.0	5.437	3.61	7.96

**POMPE AD INGRANAGGI GRUPPO 2SP**  
**GEAR PUMPS GROUP 2SP**

**FLANGIA SAE** **SAEA-SAEAOR** **SAE FLANGE**

**FLANGIA E COPERCHIO IN GHISA - FLANGE AND COVER IN CAST IRON**

GRUPPO GROUP 2SP	CILINDRATA DISPLACEMENT		PRESSIONE MAX - MAX PRESSURE						VELOCITÀ MAX MAX SPEED	PORTATA MAX MAX FLOW		VELOCITÀ MIN MIN SPEED
			P1		P2		P3					
	cm <sup>3</sup> /giro	in <sup>3</sup> /rev	bar	psi	bar	psi	bar	psi	giri/min - rpm	l/min	Gal/min	giri/min - rpm
<b>2SP 040</b>	4	0.24	260	3770	280	4060	300	4350	4000	16	4.23	500
<b>2SP 060</b>	6	0.37	260	3770	280	4060	300	4350	4000	24	6.34	500
<b>2SP 080</b>	8.5	0.52	260	3770	280	4060	300	4350	3500	29.7	7.85	500
<b>2SP 110</b>	11	0.67	260	3770	280	4060	300	4350	3500	38.5	10.17	500
<b>2SP 140</b>	14	0.85	260	3770	280	4060	300	4350	3500	49	12.95	500
<b>2SP 160</b>	16.5	1.01	240	3480	250	3625	260	3770	3500	57.7	15.24	500
<b>2SP 190</b>	19.5	1.19	220	3190	230	3335	240	3480	3300	64.3	16.99	500
<b>2SP 220</b>	22.5	1.37	200	2900	210	3045	220	3190	2800	63	16.64	500
<b>2SP 260</b>	26	1.59	180	2610	190	2755	200	2900	2500	65	17.17	500
<b>2SP 310</b>	31.5	1.92	140	2030	150	2175	160	2320	2200	69	18.22	500

Nota - Per valori di pressione superiori a quelli indicati contattare il Servizio Commerciale.  
Note - for higher pressure values please contact our Sales Dpt.

**DIMENSIONI • DIMENSIONS**

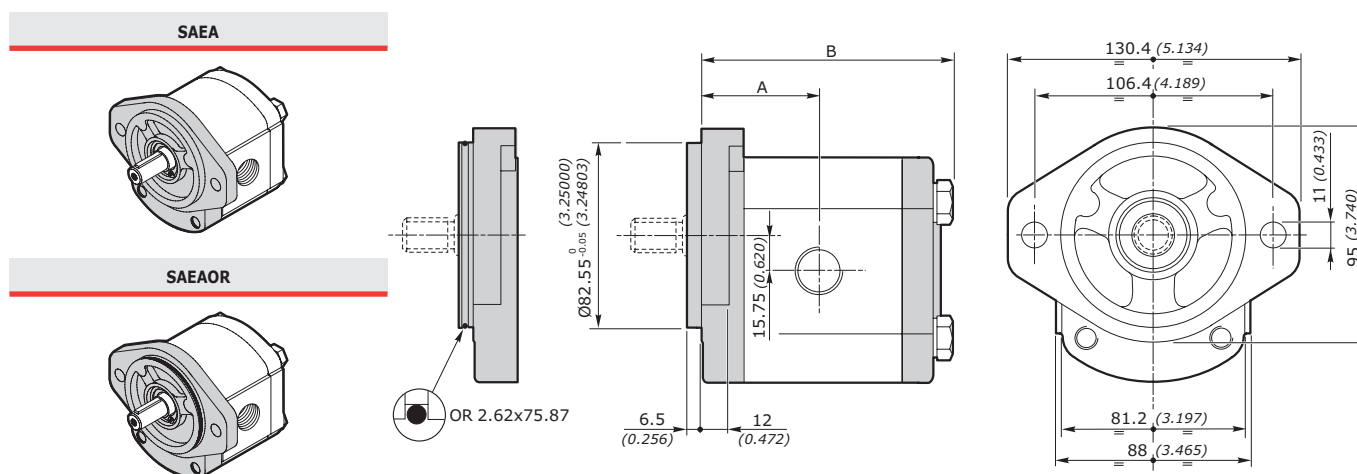

GRUPPO - GROUP 2	A		B		MASSA - MASS	
	mm	inch	mm	inch	kg	lbs
<b>2SP 040</b>	44.4	1.748	93.0	3.661	3.40	7.50
<b>2SP 060</b>	46.0	1.811	96.3	3.791	3.55	7.83
<b>2SP 080</b>	48.1	1.894	100.5	3.957	3.70	8.16
<b>2SP 110</b>	50.2	1.976	104.6	4.118	3.80	8.38
<b>2SP 140</b>	52.7	2.075	109.6	4.315	3.90	8.60
<b>2SP 160</b>	54.8	2.157	113.8	4.480	4.05	8.93
<b>2SP 190</b>	57.3	2.256	118.8	4.677	4.20	9.26
<b>2SP 220</b>	59.8	2.354	123.8	4.874	4.35	9.59
<b>2SP 260</b>	62.7	2.469	129.6	5.102	4.50	9.92
<b>2SP 310</b>	66.9	2.636	138.0	5.437	4.71	7.96

**POMPE AD INGRANAGGI GRUPPO 2SP**  
**GEAR PUMPS GROUP 2SP**
**FLANGIA TEDESCA B80C GERMAN FLANGE**

GRUPPO GROUP 2SP	CILINDRATA DISPLACEMENT		PRESSIONE MAX - MAX PRESSURE						VELOCITÀ MAX MAX SPEED		PORTATA MAX MAX FLOW		VELOCITÀ MIN MIN SPEED	
			P1		P2		P3							
	cm <sup>3</sup> /giro	in <sup>3</sup> /rev	bar	psi	bar	psi	bar	psi	giri/min - rpm	l/min	Gal/min	giri/min - rpm		
<b>2SP 040</b>	4	0.24	250	3625	270	3915	290	4205	4000	16	4.23	500		
<b>2SP 060</b>	6	0.37	250	3625	270	3915	290	4205	4000	24	6.34	500		
<b>2SP 080</b>	8.5	0.52	250	3625	270	3915	290	4205	3500	29.7	7.85	500		
<b>2SP 110</b>	11	0.67	250	3625	270	3915	290	4205	3500	38.5	10.17	500		
<b>2SP 140</b>	14	0.85	250	3625	270	3915	290	4205	3500	49	12.95	500		
<b>2SP 160</b>	16.5	1.01	230	3335	240	3480	250	3625	3500	57.7	15.24	500		
<b>2SP 190</b>	19.5	1.19	210	3045	220	3190	230	3335	3300	64.3	16.99	500		
<b>2SP 220</b>	22.5	1.37	190	2755	200	2900	210	3045	2800	63	16.64	500		
<b>2SP 260</b>	26	1.59	170	2465	180	2610	190	2755	2500	65	17.17	500		
<b>2SP 310</b>	31.5	1.92	130	1885	140	2030	150	2175	2200	69	18.22	500		

Nota - Per valori di pressione superiori a quelli indicati contattare il Servizio Commerciale.  
 Note - for higher pressure values please contact our Sales Dept.

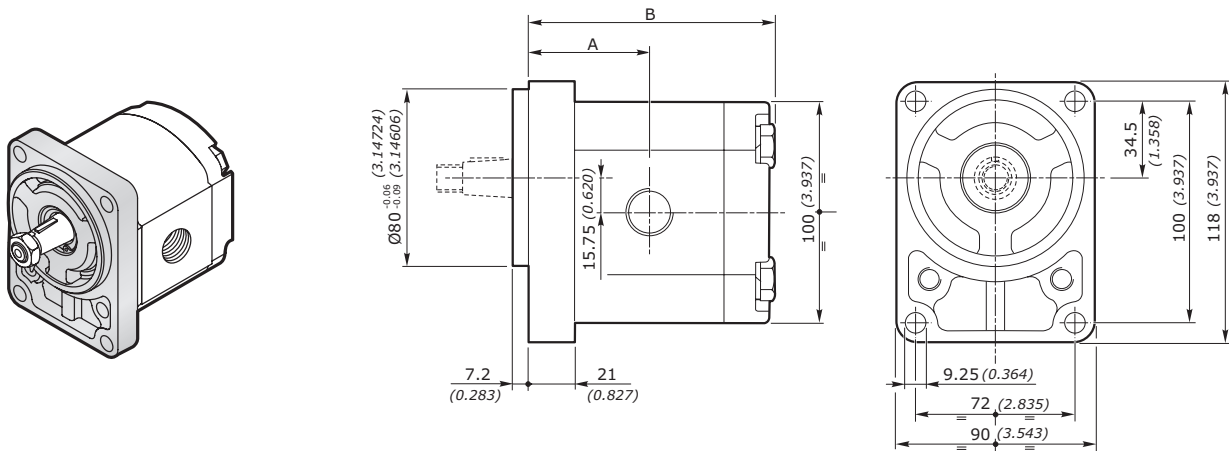
**DIMENSIONI • DIMENSIONS**

GRUPPO - GROUP 2	A		B		MASSA - MASS	
	mm	inch	mm	inch	kg	lbs
<b>2SP 040</b>	46.4	1.827	95.0	3.740	2.30	5.07
<b>2SP 060</b>	48.0	1.890	98.3	3.870	2.45	5.40
<b>2SP 080</b>	50.1	1.972	102.5	4.035	2.60	5.73
<b>2SP 110</b>	52.2	2.055	106.6	4.197	2.70	5.95
<b>2SP 140</b>	54.7	2.154	111.6	4.394	2.80	6.17
<b>2SP 160</b>	56.8	2.236	115.8	4.559	2.95	6.51
<b>2SP 190</b>	59.3	2.335	120.8	4.756	3.10	6.84
<b>2SP 220</b>	61.8	2.433	125.8	4.953	3.25	7.17
<b>2SP 260</b>	64.7	2.547	131.6	5.181	3.40	7.50
<b>2SP 310</b>	68.9	2.715	140.0	5.516	3.61	7.96



**POMPE AD INGRANAGGI GRUPPO 2SP**  
**GEAR PUMPS GROUP 2SP**

**FLANGIA B50C FLANGE**

GRUPPO GROUP 2SP	CILINDRATA DISPLACEMENT		PRESSIONE MAX - MAX PRESSURE						VELOCITÀ MAX MAX SPEED		PORTATA MAX MAX FLOW		VELOCITÀ MIN MIN SPEED	
			P1		P2		P3							
	cm³/giro	in³/rev	bar	psi	bar	psi	bar	psi	giri/min - rpm	l/min	Gal/min	giri/min - rpm		
<b>2SP 040</b>	4	0.24	250	3625	270	3915	290	4205	4000	16	4.23	500		
<b>2SP 060</b>	6	0.37	250	3625	270	3915	290	4205	4000	24	6.34	500		
<b>2SP 080</b>	8.5	0.52	250	3625	270	3915	290	4205	3500	29.7	7.85	500		
<b>2SP 110</b>	11	0.67	250	3625	270	3915	290	4205	3500	38.5	10.17	500		
<b>2SP 140</b>	14	0.85	250	3625	270	3915	290	4205	3500	49	12.95	500		
<b>2SP 160</b>	16.5	1.01	230	3335	240	3480	250	3625	3500	57.7	15.24	500		
<b>2SP 190</b>	19.5	1.19	210	3045	220	3190	230	3335	3300	64.3	16.99	500		
<b>2SP 220</b>	22.5	1.37	190	2755	200	2900	210	3045	2800	63	16.64	500		
<b>2SP 260</b>	26	1.59	170	2465	180	2610	190	2755	2500	65	17.17	500		
<b>2SP 310</b>	31.5	1.92	130	1885	140	2030	150	2175	2200	69	18.22	500		

Nota - Per valori di pressione superiori a quelli indicati contattare il Servizio Commerciale.  
 Note - for higher pressure values please contact our Sales Dpt.

**DIMENSIONI • DIMENSIONS**

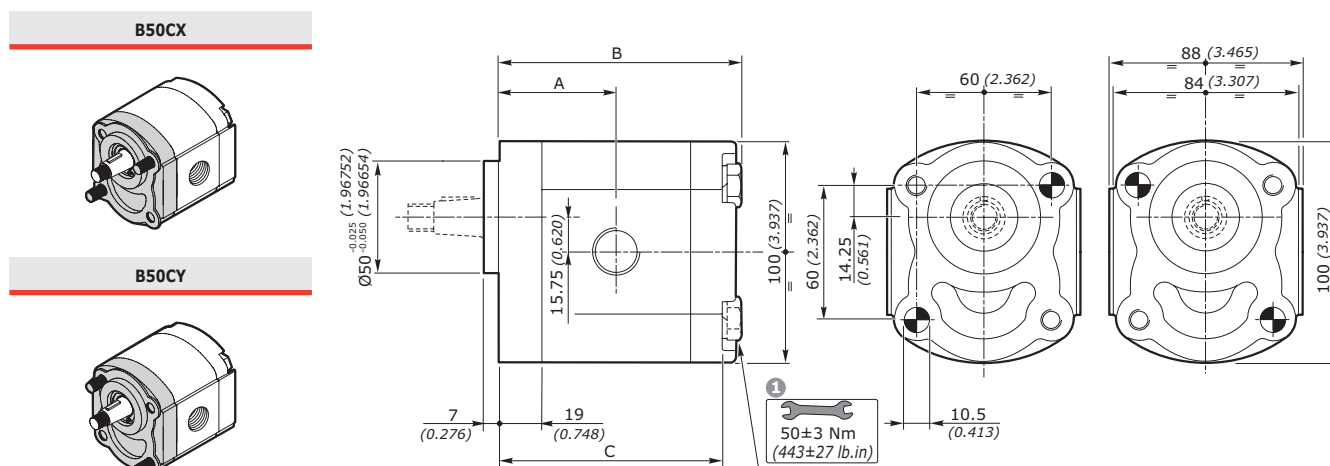

**1**  
 Coppia di serraggio viti:  $50 \pm 3\text{Nm}$  (viti classe 10.9-12.9 UNI EN 20898/1)  
 Il kit viti per il fissaggio della pompa è da ordinare separatamente.  
 Codice di ordinazione: **0029W** (+ lunghezza **L** - vedi tabella)  
 Il fissaggio della pompa può essere effettuato con 2 viti prigioniere classe 10.9-12.9 UNI EN 20898/1 preserrate:  $40 \pm 3\text{Nm}$ . Fissare la pompa mediante dadi autobloccanti con coppia di serraggio:  $50 \pm 3\text{Nm}$

**1**  
 Screw tightening torque:  $443 \pm 27\text{lb.in}$  (screws 10.9-12.9 UNI EN 20898/1).  
 The screw kit for the pump assembly should be ordered separately.  
 Ordering code: **0029W** (+ length **L** - see table)  
 The pump assembling should be made with 2 screws stud type 10.9-12.9 UNI EN 20898/1 pre-tighten  $354 \pm 27\text{lb.in}$ . Fix the pump by self-locking nuts with tightening torque:  $443 \pm 27\text{lb.in}$

GRUPPO - GROUP 2	A		B		C		L <b>1</b>		MASSA - MASS	
	mm	inch	mm	inch	mm	inch	mm	inch	kg	lbs
<b>2SP 040</b>	44.4	1.748	93.0	3.661	84.0	3.307	105	4.134	2.30	5.07
<b>2SP 060</b>	46.0	1.811	96.3	3.791	87.3	3.437	105	4.134	2.45	5.40
<b>2SP 080</b>	48.1	1.894	100.5	3.957	91.5	3.602	110	4.331	2.60	5.73
<b>2SP 110</b>	50.2	1.976	104.6	4.118	95.6	3.764	115	4.528	2.70	5.95
<b>2SP 140</b>	52.7	2.075	109.6	4.315	100.6	3.961	120	4.724	2.80	6.17
<b>2SP 160</b>	54.8	2.157	113.8	4.480	104.8	4.126	125	4.921	2.95	6.51
<b>2SP 190</b>	57.3	2.256	118.8	4.677	109.8	4.323	130	5.118	3.10	6.84
<b>2SP 220</b>	59.8	2.354	123.8	4.874	114.8	4.520	135	5.315	3.25	7.17
<b>2SP 260</b>	62.7	2.469	129.6	5.102	120.6	4.748	140	5.512	3.40	7.50
<b>2SP 310</b>	66.9	2.636	138.0	5.437	129.0	5.083	150	5.910	3.61	7.96

**POMPE AD INGRANAGGI GRUPPO 2SP**  
**GEAR PUMPS GROUP 2SP**
**FLANGIA E52C FLANGE**

GRUPPO GROUP 2SP	CILINDRATA DISPLACEMENT		PRESSIONE MAX - MAX PRESSURE						VELOCITÀ MAX MAX SPEED	PORTATA MAX MAX FLOW		VELOCITÀ MIN MIN SPEED
	cm <sup>3</sup> /giro	in <sup>3</sup> /rev	P1		P2		P3			l/min	Gal/min	
			bar	psi	bar	psi	bar	psi	giri/min - rpm			giri/min - rpm
<b>2SP 040</b>	4	0.24	250	3625	270	3915	290	4205	4000	16	4.23	500
<b>2SP 060</b>	6	0.37	250	3625	270	3915	290	4205	4000	24	6.34	500
<b>2SP 080</b>	8.5	0.52	250	3625	270	3915	290	4205	3500	29.7	7.85	500
<b>2SP 110</b>	11	0.67	250	3625	270	3915	290	4205	3500	38.5	10.17	500
<b>2SP 140</b>	14	0.85	250	3625	270	3915	290	4205	3500	49	12.95	500
<b>2SP 160</b>	16.5	1.01	230	3335	240	3480	250	3625	3500	57.7	15.24	500
<b>2SP 190</b>	19.5	1.19	210	3045	220	3190	230	3335	3300	64.3	16.99	500
<b>2SP 220</b>	22.5	1.37	190	2755	200	2900	210	3045	2800	63	16.64	500
<b>2SP 260</b>	26	1.59	170	2465	180	2610	190	2755	2500	65	17.17	500
<b>2SP 310</b>	31.5	1.92	130	1885	140	2030	150	2175	2200	69	18.22	500

Nota - Per valori di pressione superiori a quelli indicati contattare il Servizio Commerciale.  
 Note - for higher pressure values please contact our Sales Dept.

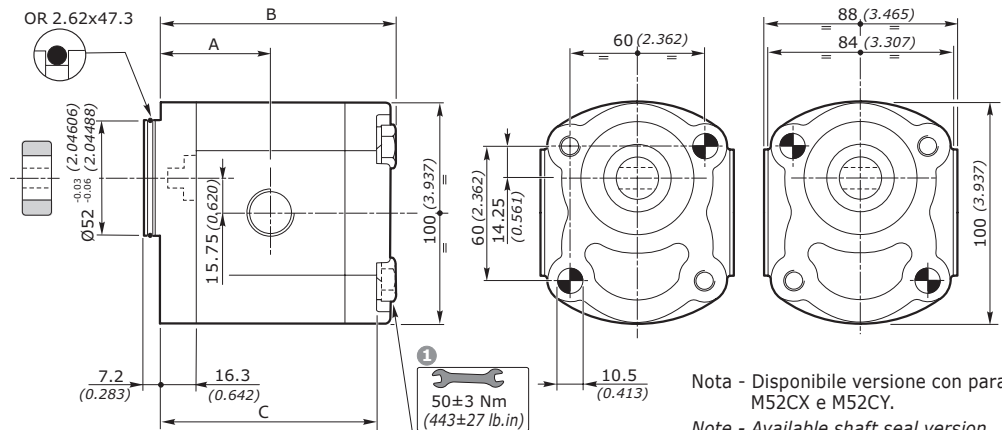
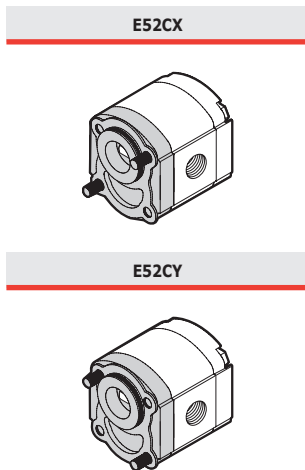
**DIMENSIONI • DIMENSIONS**

Nota - Disponibile versione con paraolio M52CX e M52CY.  
 Note - Available shaft seal version M52CX and M52CY.

**1** Coppia di serraggio viti:  $50 \pm 3\text{Nm}$  (viti classe 10.9-12.9 UNI EN 20898/1)  
 Il kit viti per il fissaggio della pompa è da ordinare separatamente.  
 Codice di ordinazione: **0029W** (+ lunghezza L - vedi tabella)  
 Il fissaggio della pompa può essere effettuato con 2 viti prigioniere classe 10.9-12.9 UNI EN 20898/1 preserrate:  $40 \pm 3\text{Nm}$ . Fissare la pompa mediante dadi autobloccanti con coppia di serraggio:  $50 \pm 3\text{Nm}$

**1** Screw tightening torque:  $443 \pm 27\text{lb.in}$  (screws 10.9-12.9 UNI EN 20898/1).  
 The screw kit for the pump assembly should be ordered separately.  
 Ordering code: **0029W** (+ length L - see table)  
 The pump assembling should be made with 2 screws stud type 10.9-12.9 UNI EN 20898/1 pre-tighten  $354 \pm 27\text{lb.in}$ . Fix the pump by self-locking nuts with tightening torque:  $443 \pm 27\text{lb.in}$

GRUPPO - GROUP 2	A		B		C		L <b>1</b>		MASSA - MASS	
	mm	inch	mm	inch	mm	inch	mm	inch	kg	lbs
<b>2SP 040</b>	41.7	1.642	90.3	3.555	81.3	3.201	100	3.937	2.30	5.07
<b>2SP 060</b>	43.3	1.705	93.6	3.685	84.6	3.331	105	4.134	2.45	5.40
<b>2SP 080</b>	45.4	1.787	97.8	3.850	88.8	3.496	110	4.331	2.60	5.73
<b>2SP 110</b>	47.5	1.870	101.9	4.012	92.9	3.657	115	4.528	2.70	5.95
<b>2SP 140</b>	50.0	1.969	106.9	4.209	97.9	3.854	120	4.724	2.80	6.17
<b>2SP 160</b>	52.1	2.051	111.1	4.374	102.1	4.020	120	4.724	2.95	6.51
<b>2SP 190</b>	54.6	2.150	116.1	4.571	107.1	4.217	125	4.921	3.10	6.84
<b>2SP 220</b>	57.1	2.248	121.1	4.768	112.1	4.413	130	5.118	3.25	7.17
<b>2SP 260</b>	60.0	2.362	126.9	4.996	117.9	4.642	140	5.512	3.40	7.50
<b>2SP 310</b>	64.2	2.529	135.3	5.331	126.3	4.988	145	5.713	3.61	7.96

**POMPE AD INGRANAGGI GRUPPO 2SP**  
**GEAR PUMPS GROUP 2SP**

**FLANGIA PERKINS P400D PERKINS FLANGE**

GRUPPO GROUP 2SP	CILINDRATA DISPLACEMENT		PRESSIONE MAX - MAX PRESSURE						VELOCITÀ MAX MAX SPEED		PORTATA MAX MAX FLOW		VELOCITÀ MIN MIN SPEED	
			P1		P2		P3							
	cm <sup>3</sup> /giro	in <sup>3</sup> /rev	bar	psi	bar	psi	bar	psi	giri/min - rpm	l/min	Gal/min	giri/min - rpm		
<b>2SP 040</b>	4	0.24	250	3625	270	3915	290	4205	4000	16	4.23	500		
<b>2SP 060</b>	6	0.37	250	3625	270	3915	290	4205	4000	24	6.34	500		
<b>2SP 080</b>	8.5	0.52	250	3625	270	3915	290	4205	3500	29.7	7.85	500		
<b>2SP 110</b>	11	0.67	250	3625	270	3915	290	4205	3500	38.5	10.17	500		
<b>2SP 140</b>	14	0.85	250	3625	270	3915	290	4205	3500	49	12.95	500		
<b>2SP 160</b>	16.5	1.01	230	3335	240	3480	250	3625	3500	57.7	15.24	500		
<b>2SP 190</b>	19.5	1.19	210	3045	220	3190	230	3335	3300	64.3	16.99	500		
<b>2SP 220</b>	22.5	1.37	190	2755	200	2900	210	3045	2800	63	16.64	500		
<b>2SP 260</b>	26	1.59	170	2465	180	2610	190	2755	2500	65	17.17	500		
<b>2SP 310</b>	31.5	1.92	130	1885	140	2030	150	2175	2200	69	18.22	500		

Nota - Per valori di pressione superiori a quelli indicati contattare il Servizio Commerciale.  
Note - for higher pressure values please contact our Sales Dpt.

**DIMENSIONI • DIMENSIONS**

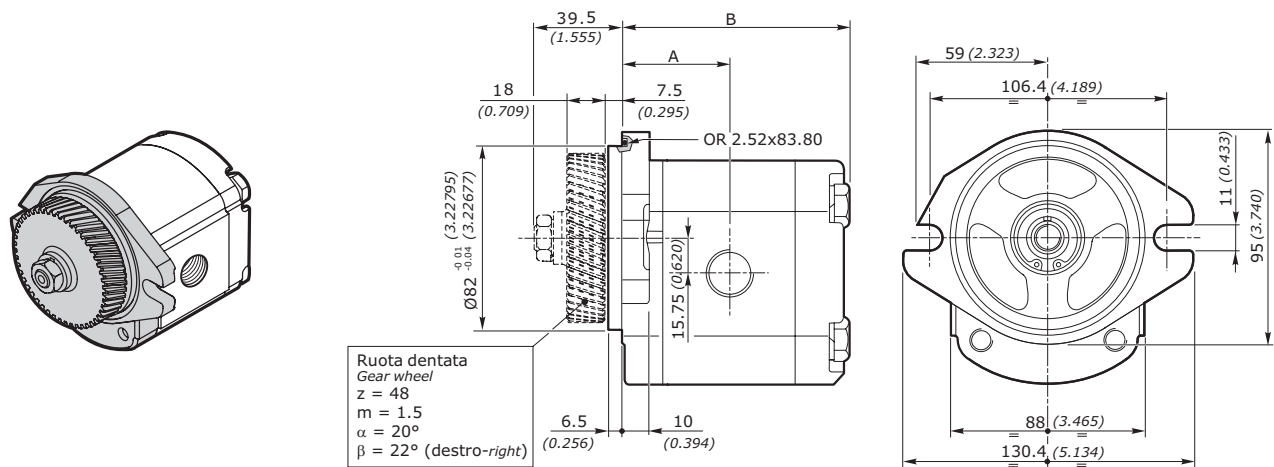

GRUPPO - GROUP 2	A		B		MASSA - MASS	
	mm	inch	mm	inch	kg	lbs
<b>2SP 040</b>	44.4	1.748	93.0	3.661	2.30	5.07
<b>2SP 060</b>	46.0	1.811	96.3	3.791	2.45	5.40
<b>2SP 080</b>	48.1	1.894	100.5	3.957	2.60	5.73
<b>2SP 110</b>	50.2	1.976	104.6	4.118	2.70	5.95
<b>2SP 140</b>	52.7	2.075	109.6	4.315	2.80	6.17
<b>2SP 160</b>	54.8	2.157	113.8	4.480	2.95	6.51
<b>2SP 190</b>	57.3	2.256	118.8	4.677	3.10	6.84
<b>2SP 220</b>	59.8	2.354	123.8	4.874	3.25	7.17
<b>2SP 260</b>	62.7	2.469	129.6	5.102	3.40	7.50
<b>2SP 310</b>	66.9	2.636	138.0	5.437	3.61	7.96

**POMPE AD INGRANAGGI GRUPPO 2SP**  
**GEAR PUMPS GROUP 2SP**

 VERSIONE DA UTILIZZARE IN PRESENZA DI CARICHI ASSIALI E/O RADIALI  
 VERSION TO BE USED WITH AXIAL AND/OR RADIAL LOADS

**FLANGIA SUPEUR FLANGE**

GRUPPO GROUP 2SP	CILINDRATA DISPLACEMENT		PRESSIONE MAX - MAX PRESSURE						VELOCITÀ MAX MAX SPEED	PORTATA MAX MAX FLOW		VELOCITÀ MIN MIN SPEED
			P1		P2		P3					
	cm <sup>3</sup> /giro	in <sup>3</sup> /rev	bar	psi	bar	psi	bar	psi	giri/min - rpm	l/min	Gal/min	giri/min - rpm
<b>2SP 040</b>	4	0.24	250	3625	270	3915	290	4205	4000	16	4.23	500
<b>2SP 060</b>	6	0.37	250	3625	270	3915	290	4205	4000	24	6.34	500
<b>2SP 080</b>	8.5	0.52	250	3625	270	3915	290	4205	3500	29.7	7.85	500
<b>2SP 110</b>	11	0.67	250	3625	270	3915	290	4205	3500	38.5	10.17	500
<b>2SP 140</b>	14	0.85	250	3625	270	3915	290	4205	3500	49	12.95	500
<b>2SP 160</b>	16.5	1.01	230	3335	240	3480	250	3625	3500	57.7	15.24	500
<b>2SP 190</b>	19.5	1.19	210	3045	220	3190	230	3335	3300	64.3	16.99	500
<b>2SP 220</b>	22.5	1.37	190	2755	200	2900	210	3045	2800	63	16.64	500
<b>2SP 260</b>	26	1.59	170	2465	180	2610	190	2755	2500	65	17.17	500
<b>2SP 310</b>	31.5	1.92	130	1885	140	2030	150	2175	2200	69	18.22	500

 Nota - Per valori di pressione superiori a quelli indicati contattare  
 il Servizio Commerciale.  
 Note - for higher pressure values please contact our Sales Dpt.

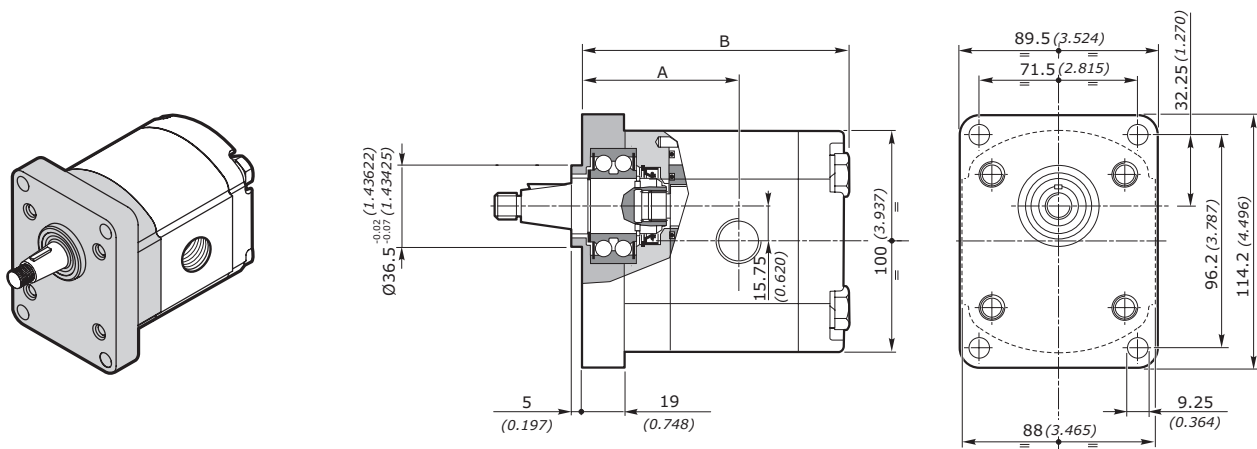
**DIMENSIONI • DIMENSIONS**

 La flangia SUPEUR è sempre allestita con anello di rinforzo.  
 SUPEUR flange is always equipped with sealing ring

GRUPPO - GROUP 2	A		B		MASSA - MASS	
	mm	inch	mm	inch	kg	lbs
<b>2SP 040</b>	64.4	2.535	113.0	4.449	2.80	6.17
<b>2SP 060</b>	66.0	2.598	116.3	4.579	2.95	6.50
<b>2SP 080</b>	68.1	2.681	120.5	4.744	3.10	6.84
<b>2SP 110</b>	70.2	2.764	124.6	4.906	3.20	7.06
<b>2SP 140</b>	72.7	2.863	129.6	5.102	3.30	7.28
<b>2SP 160</b>	74.8	2.945	133.8	5.268	3.45	7.61
<b>2SP 190</b>	77.3	3.043	138.8	5.465	3.60	7.94
<b>2SP 220</b>	79.8	3.142	143.8	5.661	3.75	8.27
<b>2SP 260</b>	82.7	3.256	149.6	5.890	3.90	8.60
<b>2SP 310</b>	86.9	3.424	158.0	6.225	4.11	9.06

**POMPE AD INGRANAGGI GRUPPO 2SP**  
**GEAR PUMPS GROUP 2SP**

**FLANGIA SUPEUR FLANGE**

**FLANGIA E COPERCHIO IN GHISA - FLANGE AND COVER IN CAST IRON**

GRUPPO GROUP 2SP	CILINDRATA DISPLACEMENT		PRESSIONE MAX - MAX PRESSURE						VELOCITÀ MAX MAX SPEED	PORTATA MAX MAX FLOW		VELOCITÀ MIN MIN SPEED
			P1		P2		P3					
	cm <sup>3</sup> /giro	in <sup>3</sup> /rev	bar	psi	bar	psi	bar	psi	giri/min - rpm	l/min	Gal/min	giri/min - rpm
<b>2SP 040</b>	4	0.24	260	3770	280	4060	300	4350	4000	16	4.23	500
<b>2SP 060</b>	6	0.37	260	3770	280	4060	300	4350	4000	24	6.34	500
<b>2SP 080</b>	8.5	0.52	260	3770	280	4060	300	4350	3500	29.7	7.85	500
<b>2SP 110</b>	11	0.67	260	3770	280	4060	300	4350	3500	38.5	10.17	500
<b>2SP 140</b>	14	0.85	260	3770	280	4060	300	4350	3500	49	12.95	500
<b>2SP 160</b>	16.5	1.01	240	3480	250	3625	260	3770	3500	57.7	15.24	500
<b>2SP 190</b>	19.5	1.19	220	3190	230	3335	240	3480	3300	64.3	16.99	500
<b>2SP 220</b>	22.5	1.37	200	2900	210	3045	220	3190	2800	63	16.64	500
<b>2SP 260</b>	26	1.59	180	2610	190	2755	200	2900	2500	65	17.17	500
<b>2SP 310</b>	31.5	1.92	140	2030	150	2175	160	2320	2200	69	18.22	500

Nota - Per valori di pressione superiori a quelli indicati contattare il Servizio Commerciale.  
Note - for higher pressure values please contact our Sales Dpt.

**DIMENSIONI • DIMENSIONS**

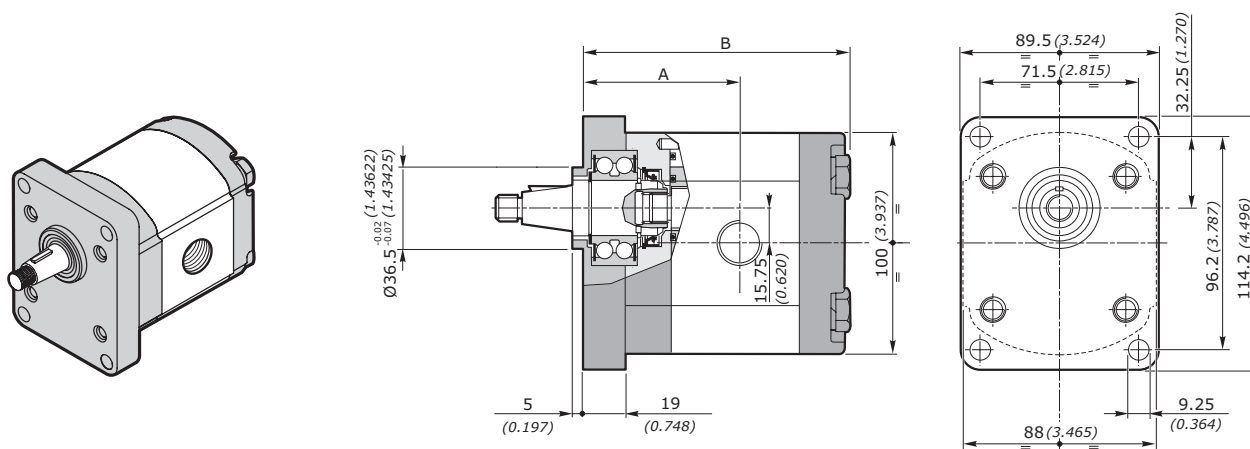

La flangia SUPEUR è sempre allestita con anello di rinforzo.  
SUPEUR flange is always equipped with sealing ring

GRUPPO - GROUP 2	A		B		MASSA - MASS	
	mm	inch	mm	inch	kg	lbs
<b>2SP 040</b>	64.4	2.535	113.0	4.449	3.467	7.643
<b>2SP 060</b>	66.0	2.598	116.3	4.579	3.617	7.974
<b>2SP 080</b>	68.1	2.681	120.5	4.744	3.767	8.304
<b>2SP 110</b>	70.2	2.764	124.6	4.906	3.867	8.525
<b>2SP 140</b>	72.7	2.863	129.6	5.102	3.967	8.745
<b>2SP 160</b>	74.8	2.945	133.8	5.268	4.117	9.076
<b>2SP 190</b>	77.3	3.043	138.8	5.465	4.267	9.407
<b>2SP 220</b>	79.8	3.142	143.8	5.661	4.417	9.737
<b>2SP 260</b>	82.7	3.256	149.6	5.890	4.567	10.068
<b>2SP 310</b>	86.9	3.424	158.0	6.225	4.777	10.531

**POMPE AD INGRANAGGI GRUPPO 2SP**  
**GEAR PUMPS GROUP 2SP**
**FLANGIA SAE SAEB\* SAEB FLANGE**
**FLANGIA E COPERCHIO IN GHISA - FLANGE AND COVER IN CAST IRON**

GRUPPO GROUP 2SP	CILINDRATA DISPLACEMENT		PRESSIONE MAX - MAX PRESSURE						VELOCITÀ MAX MAX SPEED	PORTATA MAX MAX FLOW		VELOCITÀ MIN MIN SPEED
	cm <sup>3</sup> /giro in <sup>3</sup> /rev	bar	P1		P2		P3			l/min	Gal/min	
			psi	bar	psi	bar	psi	bar	giri/min - rpm			giri/min - rpm
2SP 040	4	0.24	260	3770	280	4060	300	4350	4000	16	4.23	500
2SP 060	6	0.37	260	3770	280	4060	300	4350	4000	24	6.34	500
2SP 080	8.5	0.52	260	3770	280	4060	300	4350	3500	29.7	7.85	500
2SP 110	11	0.67	260	3770	280	4060	300	4350	3500	38.5	10.17	500
2SP 140	14	0.85	260	3770	280	4060	300	4350	3500	49	12.95	500
2SP 160	16.5	1.01	240	3480	250	3625	260	3770	3500	57.7	15.24	500
2SP 190	19.5	1.19	220	3190	230	3335	240	3480	3300	64.3	16.99	500
2SP 220	22.5	1.37	200	2900	210	3045	220	3190	2800	63	16.64	500
2SP 260	26	1.59	180	2610	190	2755	200	2900	2500	65	17.17	500
2SP 310	31.5	1.92	140	2030	150	2175	160	2320	2200	69	18.22	500

Nota - Per valori di pressione superiori a quelli indicati contattare il Servizio Commerciale.  
 Note - for higher pressure values please contact our Sales Dpt.

\* Contattare il servizio commerciale. / Available soon. Please contact our Sales Dpt.

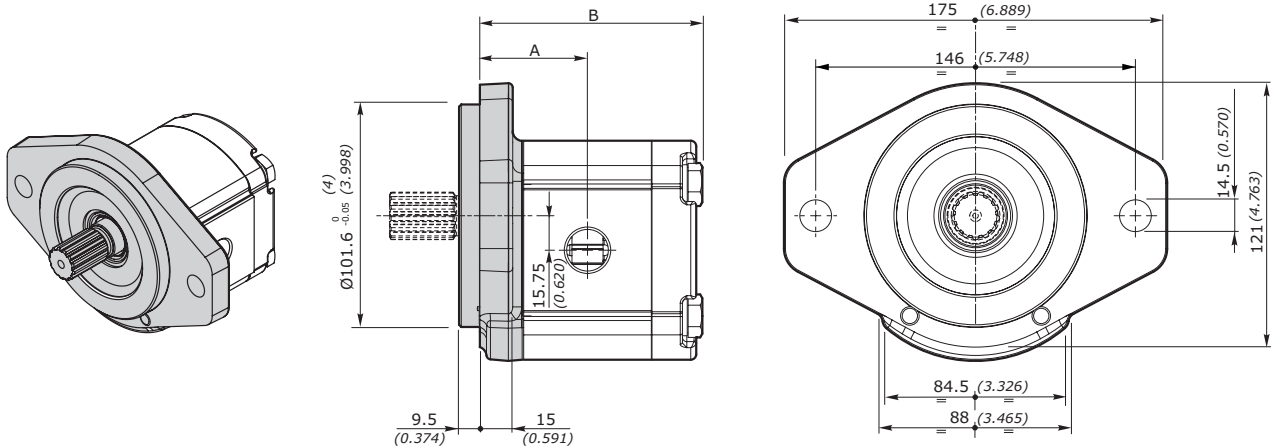
**DIMENSIONI • DIMENSIONS**

\* Configurabile come 1<sup>a</sup> pompa in tandem; elementi interni non intercambiabili  
 Configuration as 1<sup>st</sup> tandem pump; internal elements are not interchangeable

GRUPPO - GROUP 2	A		B		MASSA - MASS	
	mm	inch	mm	inch	kg	lbs
2SP 040	45.4	1.787	94	3.701	4.90	10.80
2SP 060	47.0	1.850	97.3	3.831	5.05	11.13
2SP 080	49.1	1.933	101.5	3.996	5.20	11.46
2SP 110	51.2	2.016	105.6	4.157	5.30	11.68
2SP 140	53.7	2.114	110.6	4.354	5.40	11.90
2SP 160	55.8	2.197	114.8	4.520	5.55	12.24
2SP 190	58.3	2.295	119.8	4.717	5.70	12.57
2SP 220	60.8	2.394	124.8	4.913	5.85	12.90
2SP 260	63.7	2.508	130.6	5.142	6.00	13.23
2SP 310	67.9	2.673	139	5.472	6.20	13.67

**POMPE AD INGRANAGGI GRUPPO 2SP**  
**GEAR PUMPS GROUP 2SP**

**FLANGIA SUPSAE FLANGE**

**FLANGIA E COPERCHIO IN ALLUMINIO - FLANGE AND COVER IN ALUMINIUM**

GRUPPO GROUP 2SP	CILINDRATA DISPLACEMENT		PRESSIONE MAX - MAX PRESSURE						VELOCITÀ MAX MAX SPEED	PORTATA MAX MAX FLOW		VELOCITÀ MIN MIN SPEED
	cm <sup>3</sup> /giro in <sup>3</sup> /rev	bar	P1		P2		P3			l/min	Gal/min	
			psi	bar	psi	bar	psi	giri/min - rpm	giri/min - rpm			
<b>2SP 040</b>	4	0.24	250	3625	270	3915	290	4205	4000	16	4.23	500
<b>2SP 060</b>	6	0.37	250	3625	270	3915	290	4205	4000	24	6.34	500
<b>2SP 080</b>	8.5	0.52	250	3625	270	3915	290	4205	3500	29.7	7.85	500
<b>2SP 110</b>	11	0.67	250	3625	270	3915	290	4205	3500	38.5	10.17	500
<b>2SP 140</b>	14	0.85	250	3625	270	3915	290	4205	3500	49	12.95	500
<b>2SP 160</b>	16.5	1.01	230	3335	240	3480	250	3625	3500	57.7	15.24	500
<b>2SP 190</b>	19.5	1.19	210	3045	220	3190	230	3335	3300	64.3	16.99	500
<b>2SP 220</b>	22.5	1.37	190	2755	200	2900	210	3045	2800	63	16.64	500
<b>2SP 260</b>	26	1.59	170	2465	180	2610	190	2755	2500	65	17.17	500
<b>2SP 310</b>	31.5	1.92	130	1885	140	2030	150	2175	2200	69	18.22	500

Nota - Per valori di pressione superiori a quelli indicati contattare il Servizio Commerciale.  
 Note - for higher pressure values please contact our Sales Dpt.

**DIMENSIONI • DIMENSIONS**

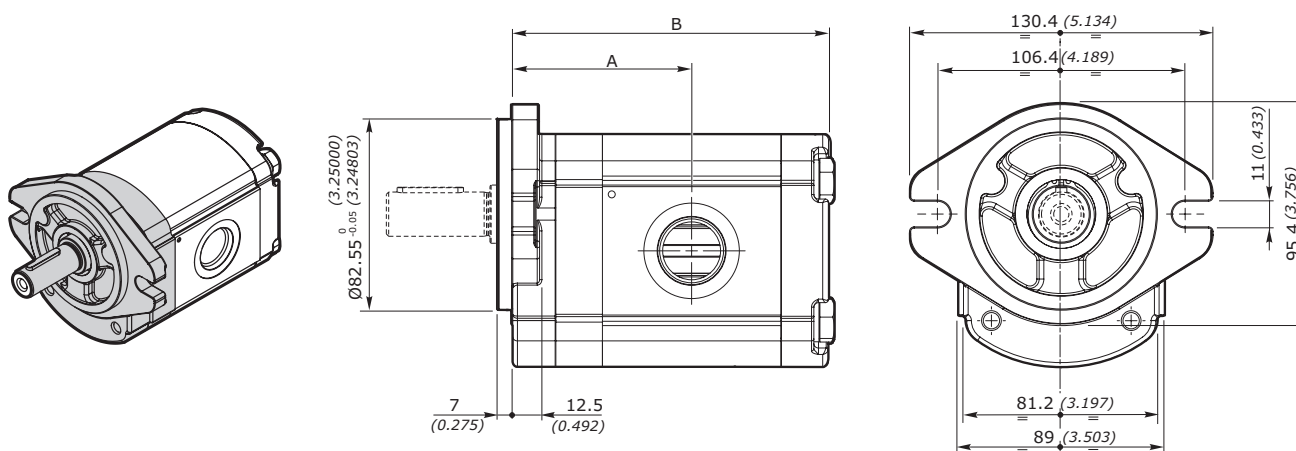

GRUPPO - GROUP 2	A		B		MASSA - MASS	
	mm	inch	mm	inch	kg	lbs
<b>2SP 040</b>	64.4	2.535	113.0	4.448	2.80	6.172
<b>2SP 060</b>	66.0	2.598	116.3	4.578	2.95	6.503
<b>2SP 080</b>	68.1	2.681	120.5	4.744	3.10	6.834
<b>2SP 110</b>	70.2	2.763	124.6	4.905	3.20	7.054
<b>2SP 140</b>	72.7	2.862	129.6	5.102	3.30	7.275
<b>2SP 160</b>	74.8	2.944	133.8	5.267	3.45	7.605
<b>2SP 190</b>	77.3	3.043	138.8	5.464	3.60	7.936
<b>2SP 220</b>	79.8	3.141	143.8	5.661	3.75	8.267
<b>2SP 260</b>	82.7	3.255	149.6	5.889	3.90	8.598
<b>2SP 310</b>	86.9	3.421	138.0	6.220	4.10	9.038

**POMPE AD INGRANAGGI GRUPPO 2SP**  
**GEAR PUMPS GROUP 2SP**
**FLANGIA SUPB80C FLANGE**

GRUPPO GROUP 2SP	CILINDRATA DISPLACEMENT		PRESSIONE MAX - MAX PRESSURE						VELOCITÀ MAX MAX SPEED	PORTATA MAX MAX FLOW		VELOCITÀ MIN MIN SPEED
	cm <sup>3</sup> /giro	in <sup>3</sup> /rev	P1		P2		P3			l/min	Gal/min	
			bar	psi	bar	psi	bar	psi				
<b>2SP 040</b>	4	0.24	250	3625	270	3915	290	4205	4000	16	4.23	500
<b>2SP 060</b>	6	0.37	250	3625	270	3915	290	4205	4000	24	6.34	500
<b>2SP 080</b>	8.5	0.52	250	3625	270	3915	290	4205	3500	29.7	7.85	500
<b>2SP 110</b>	11	0.67	250	3625	270	3915	290	4205	3500	38.5	10.17	500
<b>2SP 140</b>	14	0.85	250	3625	270	3915	290	4205	3500	49	12.95	500
<b>2SP 160</b>	16.5	1.01	230	3335	240	3480	250	3625	3500	57.7	15.24	500
<b>2SP 190</b>	19.5	1.19	210	3045	220	3190	230	3335	3300	64.3	16.99	500
<b>2SP 220</b>	22.5	1.37	190	2755	200	2900	210	3045	2800	63	16.64	500
<b>2SP 260</b>	26	1.59	170	2465	180	2610	190	2755	2500	65	17.17	500
<b>2SP 310</b>	31.5	1.92	130	1885	140	2030	150	2175	2200	69	18.22	500

Nota - Per valori di pressione superiori a quelli indicati contattare il Servizio Commerciale.  
 Note - for higher pressure values please contact our Sales Dpt.

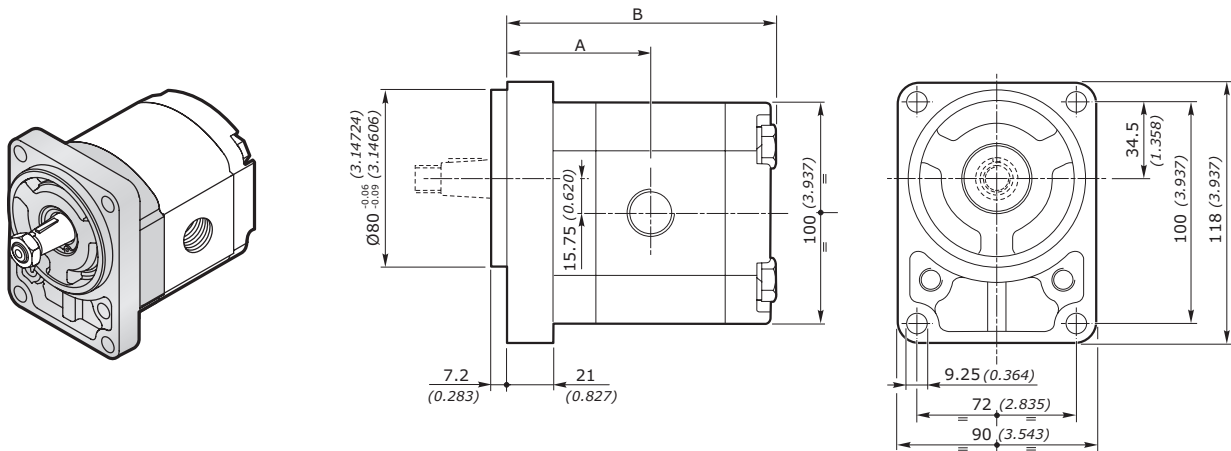
**DIMENSIONI • DIMENSIONS**

GRUPPO - GROUP 2	A		B		MASSA - MASS	
	mm	inch	mm	inch	kg	lbs
<b>2SP 040</b>	66.4	2.614	115.0	4.527	2.763	6.09
<b>2SP 060</b>	68	2.677	118.3	4.657	2.913	6.42
<b>2SP 080</b>	70.1	2.760	122.5	4.823	3.063	6.75
<b>2SP 110</b>	72.2	2.842	126.6	4.984	3.163	6.97
<b>2SP 140</b>	74.7	2.941	131.6	5.181	3.263	7.20
<b>2SP 160</b>	76.8	3.023	135.8	5.346	3.413	7.52
<b>2SP 190</b>	79.3	3.122	140.8	5.543	3.563	7.85
<b>2SP 220</b>	81.8	3.220	145.8	5.740	3.713	8.18
<b>2SP 260</b>	84.7	3.334	151.6	5.968	3.863	8.52
<b>2SP 310</b>	88.9	3.500	160.0	6.299	4.073	8.98



**POMPE AD INGRANAGGI GRUPPO 2SP**  
**GEAR PUMPS GROUP 2SP**

**FLANGIA SUPB50CX FLANGE**

GRUPPO GROUP 2SP	CILINDRATA DISPLACEMENT		PRESSIONE MAX - MAX PRESSURE						VELOCITÀ MAX MAX SPEED	PORTATA MAX MAX FLOW		VELOCITÀ MIN MIN SPEED
	cm³/giro	in³/rev	P1		P2		P3			l/min	Gal/min	
			bar	psi	bar	psi	bar	psi	giri/min - rpm			giri/min - rpm
<b>2SP 040</b>	4	0.24	250	3625	270	3915	290	4205	4000	16	4.23	500
<b>2SP 060</b>	6	0.37	250	3625	270	3915	290	4205	4000	24	6.34	500
<b>2SP 080</b>	8.5	0.52	250	3625	270	3915	290	4205	3500	29.7	7.85	500
<b>2SP 110</b>	11	0.67	250	3625	270	3915	290	4205	3500	38.5	10.17	500
<b>2SP 140</b>	14	0.85	250	3625	270	3915	290	4205	3500	49	12.95	500
<b>2SP 160</b>	16.5	1.01	230	3335	240	3480	250	3625	3500	57.7	15.24	500
<b>2SP 190</b>	19.5	1.19	210	3045	220	3190	230	3335	3300	64.3	16.99	500
<b>2SP 220</b>	22.5	1.37	190	2755	200	2900	210	3045	2800	63	16.64	500
<b>2SP 260</b>	26	1.59	170	2465	180	2610	190	2755	2500	65	17.17	500
<b>2SP 310</b>	31.5	1.92	130	1885	140	2030	150	2175	2200	69	18.22	500

Nota - Per valori di pressione superiori a quelli indicati contattare il Servizio Commerciale.  
Note - for higher pressure values please contact our Sales Dept.

**DIMENSIONI • DIMENSIONS**

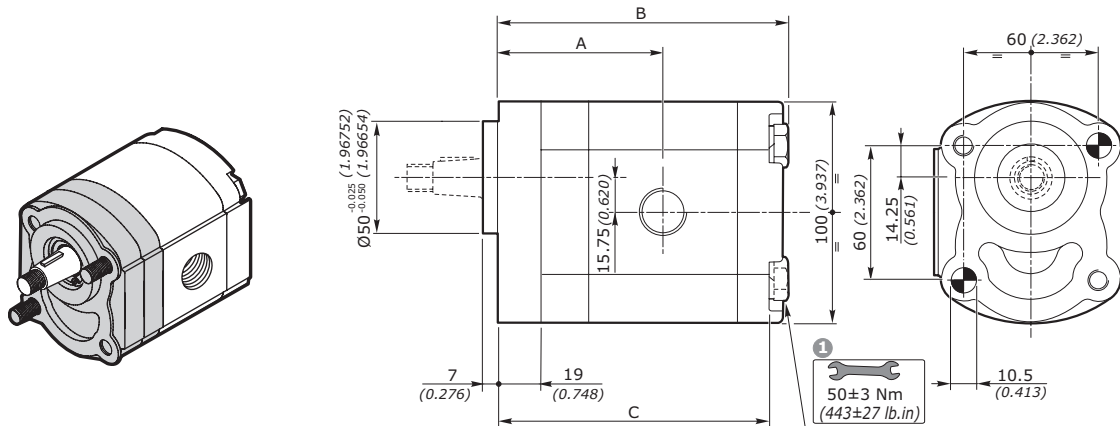

**1** Coppia di serraggio viti:  $50 \pm 3\text{Nm}$  (viti classe 10.9-12.9 UNI EN 20898/1)  
Il kit viti per il fissaggio della pompa è da ordinare separatamente.  
Codice di ordinazione: **0029W** (+ lunghezza **L** - vedi tabella)  
Il fissaggio della pompa può essere effettuato con 2 viti prigioniere classe 10.9-12.9 UNI EN 20898/1 preserrate:  $40 \pm 3\text{Nm}$ . Fissare la pompa mediante dadi autobloccanti con coppia di serraggio:  $50 \pm 3\text{Nm}$

**1** Screw tightening torque:  $443 \pm 27\text{lb-in}$  (screws 10.9-12.9 UNI EN 20898/1).  
The screw kit for the pump assembly should be ordered separately.  
Ordering code: **0029W** (+ length **L** - see table)  
The pump assembling should be made with 2 screws stud type 10.9-12.9 UNI EN 20898/1 pre-tighten  $354 \pm 27\text{lb-in}$ . Fix the pump by self-locking nuts with tightening torque:  $443 \pm 27\text{lb-in}$

GRUPPO - GROUP 2	A		B		C		L <b>1</b>		MASSA - MASS	
	mm	inch	mm	inch	mm	inch	mm	inch	kg	lbs
<b>2SP 040</b>	64.4	2.535	113.0	4.448	104.0	4.094	125	4.921	2.76	6.08
<b>2SP 060</b>	66.0	2.598	116.3	4.578	107.3	4.224	125	4.921	2.91	6.41
<b>2SP 080</b>	68.1	2.681	120.5	4.744	111.5	4.390	130	5.118	3.06	6.75
<b>2SP 110</b>	70.2	2.763	124.6	4.905	115.6	4.551	135	5.314	3.16	6.97
<b>2SP 140</b>	72.7	2.862	129.6	5.102	120.6	4.748	140	5.512	3.26	7.19
<b>2SP 160</b>	74.8	2.944	133.8	5.267	124.8	4.913	145	5.709	3.41	7.52
<b>2SP 190</b>	77.3	3.043	138.8	5.464	129.8	5.110	150	5.905	3.56	7.85
<b>2SP 220</b>	79.8	3.141	143.8	5.661	134.8	5.307	155	6.102	3.71	8.18
<b>2SP 260</b>	82.7	3.256	149.6	5.890	140.6	5.535	160	6.299	3.86	8.51
<b>2SP 310</b>	86.9	3.421	158.0	6.220	149.0	5.866	170	6.692	4.07	8.97

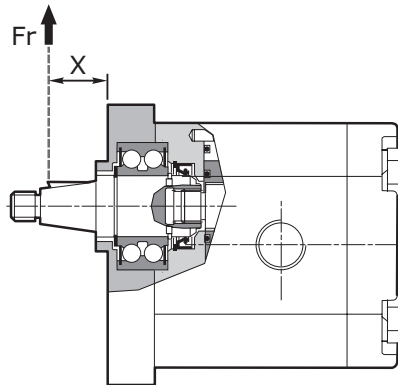
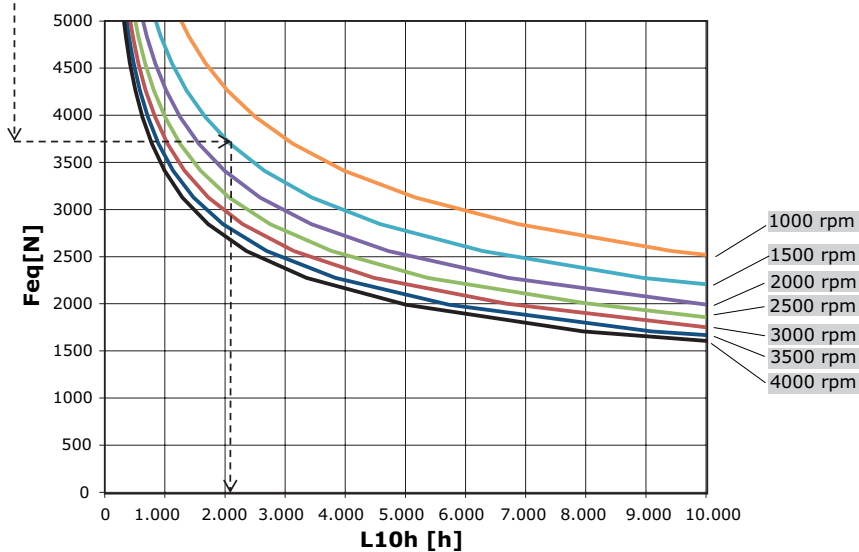
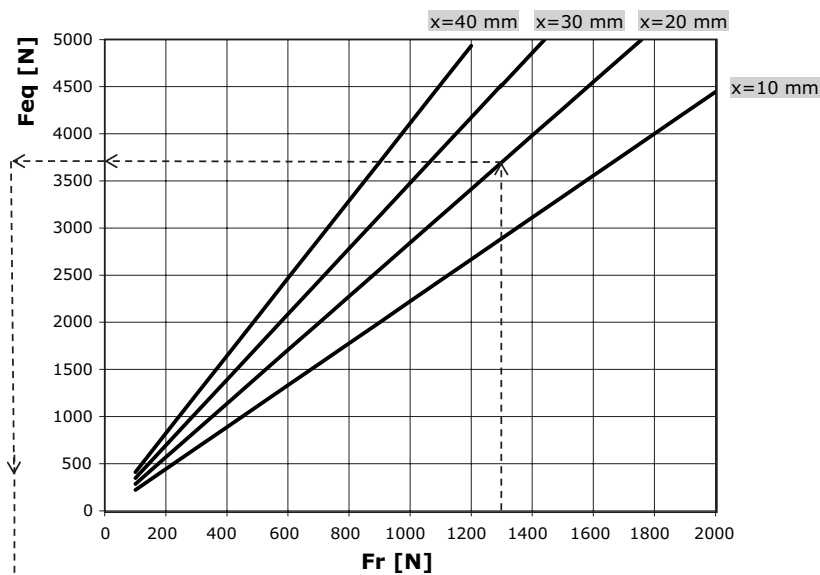
**POMPE AD INGRANAGGI GRUPPO 2SP**  
**GEAR PUMPS GROUP 2SP**
**CARICO DINAMICO EQUIVALENTE • EQUIVALENT DYNAMIC LOAD**

**DIAGRAMMA CUSCINETTI • DIAGRAM BEARING EXPECTED LIFE**

In caso di carichi combinati applicati all'albero (radiale + assiale) contattare il nostro Ufficio Tecnico.  
 In case of both radial and axial loads applied to the shaft please contact our technical department.

**POMPE AD INGRANAGGI GRUPPO 2SP**  
**GEAR PUMPS GROUP 2SP**

**CODICE ORDINAZIONE • ORDER CODE**

**2SP - G - 140 - D - EUR - B - N - 10 - 0 - G**

SIGLA - CODE	TIPO - TYPE	DESCRIZIONE - DESCRIPTION	PAGINA - PAGE
<b>2SP</b>	Tipo pompa <i>Pump type</i>	Pompa singola gruppo 2 <i>Single pump group 2</i>	5
<b>G</b>	Materiale flangia e coperchio <i>Flange and cover material</i>	<b>A</b> = alluminio / <i>aluminium</i> <b>G</b> = Ghisa / <i>Cast iron</i>	50
<b>140</b>	Cilindrata <i>Displacement</i>	Cilindrata = 14 cm <sup>3</sup> /giro <i>Displacement = 0.85 in<sup>3</sup>/rev</i>	5
<b>D</b>	Senso di rotazione <i>Rotation wise</i>	<b>D</b> = Rotazione destra / <i>Clockwise rotation</i> <b>S</b> = Rotazione sinistra / <i>Anticlockwise rotation</i> <b>R</b> = Reversibile / <i>Reversible</i>	8
<b>EUR</b>	Tipo Flangia <i>Flange type</i>	Flangia standard <i>Standard flange</i>	50
<b>B</b>	Tipo anello di tenuta <i>Seal ring type</i>	Vedi tabella compatibilità <i>See compatibility table</i>	51
<b>N</b>	Tipo guarnizione <i>Gasket type</i>	<b>N</b> = NBR <b>V</b> = Viton	50
<b>10</b>	Tipo Albero <i>Shaft type</i>	Vedi tabella compatibilità <i>See compatibility table</i>	52
<b>0</b>	Posizione connessione <i>Connection position</i>	Vedi tabella compatibilità <i>See compatibility table</i>	57
<b>G</b>	Tipo connessione <i>Connection type</i>	Vedi tabella compatibilità <i>See compatibility table</i>	58

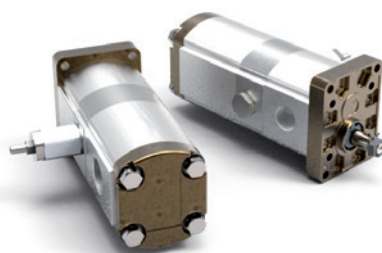

**VERSIONI CON DOPPIO PARAOLIO • DOUBLE SHAFT SEAL VERSION**

Disponibili versioni con doppio paraolio per EUR, SAEA, SAEAOR e B50C.

Available versions with double shaft seal for EUR, SAEA, SAEAOR and B50C.

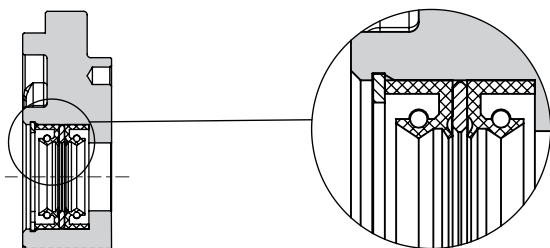

esempio • example:

**2SP - A - 160 - S - SAEA2 - B - N - 14 - N**

**SAEA2**= Doppio paraolio / *Double Shaft Seal*

Nota - La versione con paraolio è fornita con anelli a bassa pressione o alta pressione tipo K (vedi pag.51).

Note - The version with shaft seal is supplied with K rings type with low pressure or high pressure (see page 51).

**POMPE AD INGRANAGGI GRUPPO 2SP**  
**GEAR PUMPS GROUP 2SP**
**TIPOLOGIA FLANGIA • FLANGE TYPE**

2SP	EUR	SAEA	SAEAOR	B80C	B50C	E52C
A alluminio aluminium	◇	◇	◇	◇	◇	◇
G ghisa cast iron	◇	◇	◇	non disponibile not available	non disponibile not available	non disponibile not available

2SP	P400D	SUPEUR	SAEB*	SUPSAE	SUPB80C	SUPB50CX
A alluminio aluminium	◇	◇	non disponibile not available	◇	◇	◇
G ghisa cast iron	non disponibile not available	◇	◇	non disponibile not available	non disponibile not available	non disponibile not available

\* Contattare il servizio commerciale. / Available soon. Please contact our Sales Dpt.

**COMBINAZIONE FLANGIA - ANELLO DI TENUTA - GUARNIZIONE • FLANGE - SEAL RING - GASKET COMBINATION**

2SP	EUR	SAEA	SAEAOR	B80C	B50C	E52C
	Anello-Seal ring B H K	Anello-Seal ring B H K	Anello-Seal ring B H K	Anello-Seal ring B H K	Anello-Seal ring B H K	Anello-Seal ring A
NBR N	◇	◇	◇	◇	◇	◇
Viton V	●	●	●	●	●	●

2SP	P400D	SUPEUR	SAEB*	SUPSAE	SUPB80C	SUPB50CX
	Anello-Seal ring B H K	Anello-Seal ring B K	Anello-Seal ring H	Anello-Seal ring	Anello-Seal ring	Anello-Seal ring
NBR N	◇	◇	◇	◇	◇	◇
Viton V	●	●	●	●	●	●

\* Contattare il servizio commerciale. / Available soon. Please contact our Sales Dpt.

esempio • example: **2SP - A - 140 - D - EUR - B - N - 10 - 0 - G**

**EUR** = Flangia europea / European flange

**B** = Anello tenuta fino a 3 bar / Seal ring up to 3 bar

**N** = Guarnizione in NBR / NBR o-ring

◇ = Combinazione standard - Standard combination







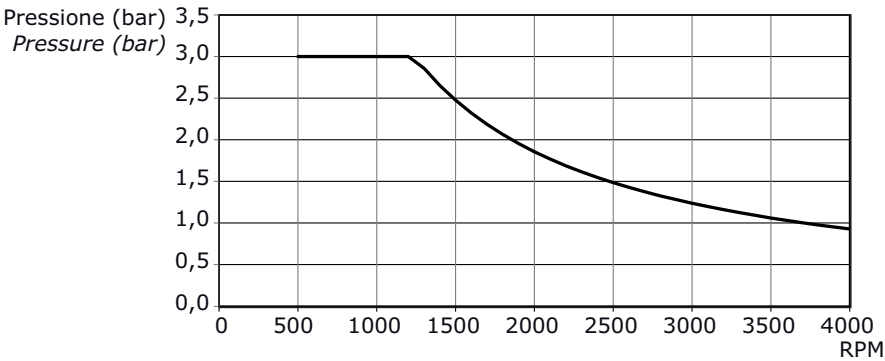
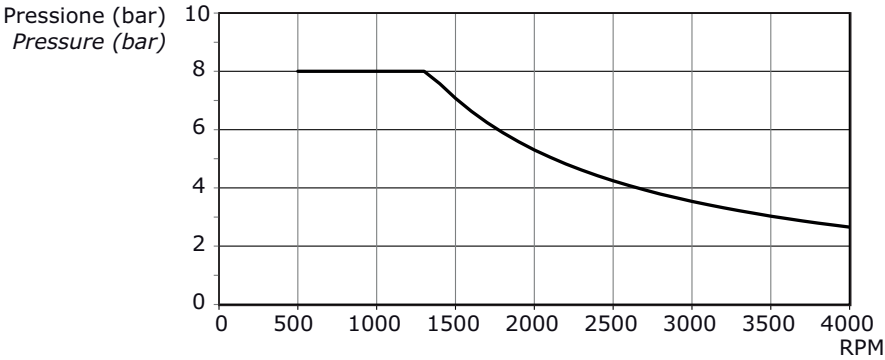
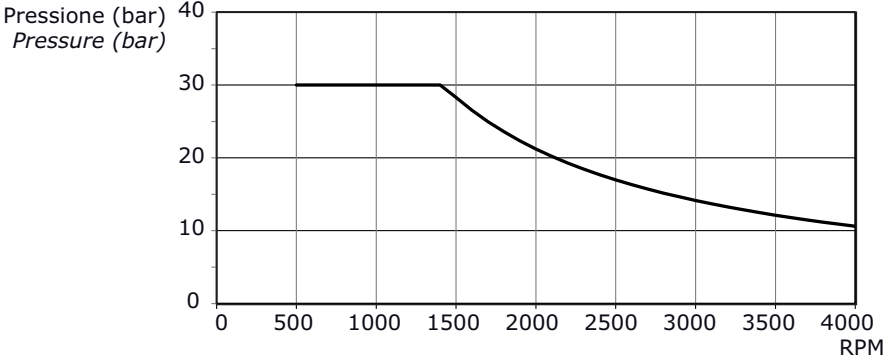





● = Combinazione disponibile - Available combination

**POMPE AD INGRANAGGI GRUPPO 2SP**  
**GEAR PUMPS GROUP 2SP**

**ANELLO DI TENUTA • SEAL RING**

SIGLA - CODE	TIPO - TYPE	DIAGRAMMA - DIAGRAM																				
<b>A</b>	Flangia senza anello di tenuta Flange without seal ring	/																				
<b>B</b>	Anello di tenuta fino a <b>3</b> bar Sealing ring up to <b>3</b> bar	 <table border="1"> <caption>Data for Seal Ring B</caption> <thead> <tr> <th>RPM</th> <th>Pressure (bar)</th> </tr> </thead> <tbody> <tr><td>500</td><td>3.0</td></tr> <tr><td>1000</td><td>3.0</td></tr> <tr><td>1250</td><td>3.0</td></tr> <tr><td>1500</td><td>2.8</td></tr> <tr><td>2000</td><td>2.0</td></tr> <tr><td>2500</td><td>1.5</td></tr> <tr><td>3000</td><td>1.2</td></tr> <tr><td>3500</td><td>1.0</td></tr> <tr><td>4000</td><td>0.8</td></tr> </tbody> </table>	RPM	Pressure (bar)	500	3.0	1000	3.0	1250	3.0	1500	2.8	2000	2.0	2500	1.5	3000	1.2	3500	1.0	4000	0.8
RPM	Pressure (bar)																					
500	3.0																					
1000	3.0																					
1250	3.0																					
1500	2.8																					
2000	2.0																					
2500	1.5																					
3000	1.2																					
3500	1.0																					
4000	0.8																					
<b>H</b>	Anello di tenuta fino a <b>8</b> bar Sealing ring up to <b>8</b> bar	 <table border="1"> <caption>Data for Seal Ring H</caption> <thead> <tr> <th>RPM</th> <th>Pressure (bar)</th> </tr> </thead> <tbody> <tr><td>500</td><td>8.0</td></tr> <tr><td>1000</td><td>8.0</td></tr> <tr><td>1250</td><td>8.0</td></tr> <tr><td>1500</td><td>7.5</td></tr> <tr><td>2000</td><td>5.5</td></tr> <tr><td>2500</td><td>4.0</td></tr> <tr><td>3000</td><td>3.5</td></tr> <tr><td>3500</td><td>3.0</td></tr> <tr><td>4000</td><td>2.5</td></tr> </tbody> </table>	RPM	Pressure (bar)	500	8.0	1000	8.0	1250	8.0	1500	7.5	2000	5.5	2500	4.0	3000	3.5	3500	3.0	4000	2.5
RPM	Pressure (bar)																					
500	8.0																					
1000	8.0																					
1250	8.0																					
1500	7.5																					
2000	5.5																					
2500	4.0																					
3000	3.5																					
3500	3.0																					
4000	2.5																					
<b>K</b>	Anello di tenuta fino a <b>30</b> bar Sealing ring up to <b>30</b> bar	 <table border="1"> <caption>Data for Seal Ring K</caption> <thead> <tr> <th>RPM</th> <th>Pressure (bar)</th> </tr> </thead> <tbody> <tr><td>500</td><td>30.0</td></tr> <tr><td>1000</td><td>30.0</td></tr> <tr><td>1250</td><td>30.0</td></tr> <tr><td>1500</td><td>28.0</td></tr> <tr><td>2000</td><td>20.0</td></tr> <tr><td>2500</td><td>15.0</td></tr> <tr><td>3000</td><td>12.0</td></tr> <tr><td>3500</td><td>10.5</td></tr> <tr><td>4000</td><td>10.0</td></tr> </tbody> </table>	RPM	Pressure (bar)	500	30.0	1000	30.0	1250	30.0	1500	28.0	2000	20.0	2500	15.0	3000	12.0	3500	10.5	4000	10.0
RPM	Pressure (bar)																					
500	30.0																					
1000	30.0																					
1250	30.0																					
1500	28.0																					
2000	20.0																					
2500	15.0																					
3000	12.0																					
3500	10.5																					
4000	10.0																					

**POMPE AD INGRANAGGI GRUPPO 2SP**  
**GEAR PUMPS GROUP 2SP**
**COMBINAZIONE ALBERO - FLANGIA • SHAFT - FLANGE COMBINATION**

2SP	EUR	SAEA	SAEAOR	B80C	B50C	E52C	P400D	SUPEUR	SAEB*	SUPSAE	SUPB80C	SUPB50CX
												
<b>10</b> Conico 1:8 Tapered 1:8	◆	●	●	●	◆		◆	◆	●	◆		
<b>11</b> Conico 1:5 Tapered 1:5	●	●	●	◆	●			●	●		◆	◆
<b>12</b> Cilindrico EUR EUR Parallel shaft	◆	●	●	◆	◆				●			
<b>13</b> Cilindr. SAEA SAEA parallel shaft	●	◆	◆	●	●				●			
<b>14</b> Scanalato SAEA 9T SAEA 9T splined	●	◆	◆	●	●				●			
<b>15</b> Scanalato DIN5482 9T (26/24) DIN5482 9T splined (26/24)	●	●	●	◆	●				●			
<b>16</b> Scanalato DIN5482 9T (20) DIN5482 9T splined (20)	●	●	●	◆	●			●	●			
<b>17</b> Fresato a dente frontale Dihedral claw						◆						
<b>30</b> Scanalato SAE SAE splined										●		
<b>31</b> Cilindrico SAE SAE Parallel shaft										●		
<b>40</b> Scanalato SAE 10T (52) SAE 10T splined (52)	●	●	●						●			
<b>41</b> Scanalato SAE 10T (37.5) SAE 10T splined (37.5)	●	●	●						●			
<b>42</b> Scanalato SAEA 11T (55.6) SAEA 11T splined (55.6)	●	●	●						●			
<b>43</b> Scanalato SAEA 11T (31.5) SAEA 11T splined (31.5)	●	●	●						●			
<b>44</b> Scanalato SAEA 11T (13.5) SAEA 11T splined (13.5)						●						
<b>45</b> Scanalato SAEB 13T (41.2) SAEB 13T splined (41.2)									◆			
<b>46</b> Cilindrico SAEB SAEB Parallel shaft										●		
<b>47</b> Cilindrico Parallel shaft											●	

◆ = Combinazione standard - Standard combination

● = Combinazione disponibile - Available combination

\* Contattare il servizio commerciale. / Available soon. Please contact our Sales Dpt.

**POMPE AD INGRANAGGI GRUPPO 2SP**  
**GEAR PUMPS GROUP 2SP**

**2SP**

DIMENSIONI ALBERO - SHAFT DIMENSIONS

<p><b>10</b> Conico 1:8 Tapered 1:8</p> <p>Coppia 140 Nm Torque 104 ft-lbs</p>	<p>Disponibile per - available for: <b>EUR- SAEA- SAEAOR- B50C- P400D- SUPEUR</b></p>	<p>Disponibile per - available for: <b>B80C</b></p>
<p><b>11</b> Conico 1:5 Tapered 1:5</p> <p>Coppia 140 Nm Torque 104 ft-lbs</p>	<p>Disponibile per - available for: <b>EUR- SAEA- SAEAOR- B50C</b></p>	<p>Disponibile per - available for: <b>B80C</b></p>
<p><b>12</b> Cilindrico EUR EUR Parallel shaft</p> <p>Coppia 80 Nm Torque 59 ft-lbs</p>	<p>Disponibile per - available for: <b>EUR- SAEA- SAEAOR- B50C</b></p>	<p>Disponibile per - available for: <b>B80C</b></p>
<p><b>13</b> Cilindrico SAEA SAEA Parallel shaft</p> <p>Coppia 90 Nm Torque 67 ft-lbs</p>	<p>Disponibile per - available for: <b>EUR- SAEA- SAEAOR- B50C</b></p>	<p>Disponibile per - available for: <b>B80C</b></p>
<p><b>14</b> Scanalato SAEA 9T SAEA 9T splined</p> <p>Coppia 100 Nm Torque 74 ft-lbs</p>	<p>Disponibile per - available for: <b>EUR- SAEA- SAEAOR- B50C</b></p>	<p>Disponibile per - available for: <b>B80C</b></p>

**POMPE AD INGRANAGGI GRUPPO 2SP**  
**GEAR PUMPS GROUP 2SP**
**2SP**

## DIMENSIONI ALBERO - SHAFT DIMENSIONS

**15**  
 Scanalato  
 DIN5482 B 17x14  
 DIN5482 9T  
 splined (26/24)

Coppia 100 Nm  
 Torque 74 ft-lbs

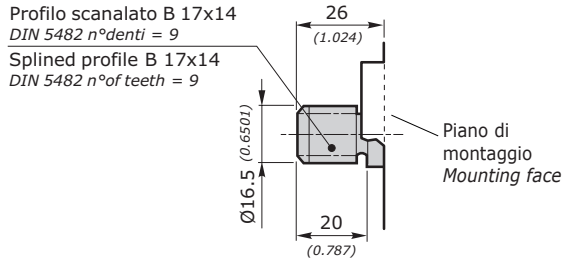

Disponibile per - available for: **EUR - SAEA - SAEAOR - B50C**

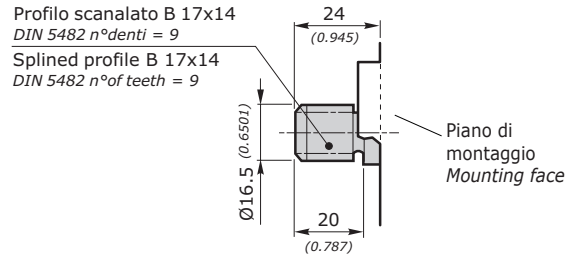

Disponibile per - available for: **B80C**

**16**  
 Scanalato  
 DIN5482  
 B 17x14  
 DIN5482 9T  
 splined (20)

Coppia 100 Nm  
 Torque 74 ft-lbs

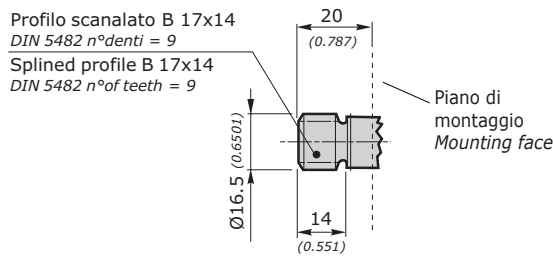

Disponibile per - available for: **EUR - SAEA - SAEAOR - B50C**

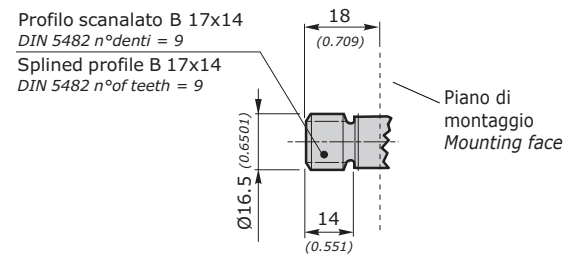

Disponibile per - available for: **B80C**

**17**  
 Fresato a dent  
 frontale  
 Dihedral claw

Coppia 80 Nm  
 Torque 59 ft-lbs

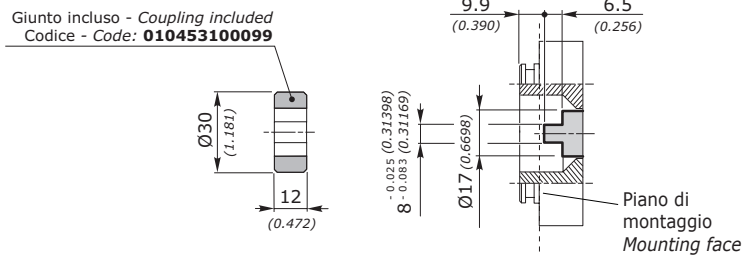

Disponibile per - available for: **E52C**

**40**  
 Scanalato SAE  
 10T (52)  
 SAE 10T  
 splined (52)

Coppia 130 Nm  
 Torque 96 ft-lbs

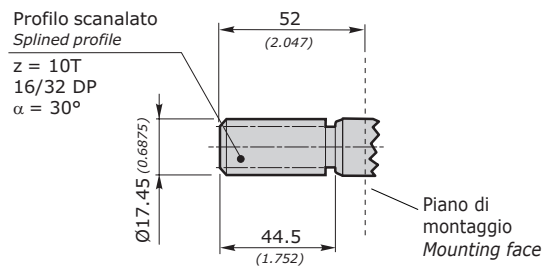

Disponibile per - available for: **SAEA - SAEAOR**

**41**  
 Scanalato SAE  
 10T (37.5)  
 SAE 10T  
 splined (37.5)

Coppia 130 Nm  
 Torque 96 ft-lbs

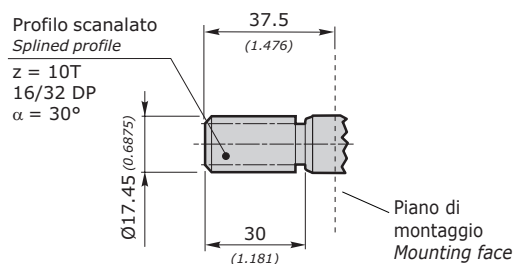

Disponibile per - available for: **SAEA - SAEAOR**



**POMPE AD INGRANAGGI GRUPPO 2SP**  
**GEAR PUMPS GROUP 2SP**

<b>2SP</b>	<b>DIMENSIONI ALBERO - SHAFT DIMENSIONS</b>
<p><b>42</b> Scanalato SAEA 11T (55.6) SAEA 11T splined (55.6)</p> <p>Coppia 150 Nm Torque 111 ft-lbs</p>	<p>Profilo scanalato Splined profile z = 11T 16/32 DP <math>\alpha = 30^\circ</math></p> <p>55.6 (2.189)</p> <p>47 (1.850)</p> <p>Ø18 (0.7092)</p> <p>Piano di montaggio Mounting face</p> <p>Disponibile per - available for: <b>SAEA - SAEAOR</b></p>
<p><b>43</b> Scanalato SAEA 11T (31.5) SAEA 11T splined (31.5)</p> <p>Coppia 150 Nm Torque 111 ft-lbs</p>	<p>Profilo scanalato Splined profile z = 11T 16/32 DP <math>\alpha = 30^\circ</math></p> <p>31.5 (1.240)</p> <p>23.8 (0.937)</p> <p>Ø18 (0.7092)</p> <p>Piano di montaggio Mounting face</p> <p>Disponibile per - available for: <b>SAEA - SAEAOR</b></p>
<p><b>44</b> Scanalato SAEA 11T (13.5) SAEA 11T splined (13.5)</p> <p>Coppia 150 Nm Torque 111 ft-lbs</p>	<p>Profilo scanalato Splined profile z = 11T 16/32 DP <math>\alpha = 30^\circ</math></p> <p>13.5 (0.531)</p> <p>23.2 (0.913)</p> <p>Ø18 (0.7092)</p> <p>Piano di montaggio Mounting face</p> <p>Disponibile per - available for: <b>E52C</b></p>
<p><b>45</b> Scanalato SAEB 13T (41.2) SAEB 13T splined (41.2)</p> <p>Coppia 280 Nm Torque 207 ft-lbs</p>	<p>Profilo scanalato Splined profile z = 13T 16/32 DP <math>\alpha = 30^\circ</math></p> <p>41.2 (1.622)</p> <p>34 (1.338)</p> <p>Ø21.8 (0.858)</p> <p>Piano di montaggio Mounting face</p> <p>Disponibile per - available for: <b>SAEB</b></p>
<p><b>46*</b> Cilindrico Parallel shaft</p> <p>Coppia 110 Nm Torque 81 ft-lbs</p> <p><small>* Solo per versione con cuscinetto. Available only for version with bearing</small></p>	<p>6<sup>+0</sup>/<sub>-0.03</sub> (0.23622) (0.23503)</p> <p>46.2 (1.818)</p> <p>40.2 (1.582)</p> <p>Ø18 (0.7092)</p> <p>M8</p> <p>Piano di montaggio Mounting face</p> <p>Disponibile per - available for: <b>SUPEUR - SUPSAE</b></p>

**POMPE AD INGRANAGGI GRUPPO 2SP**  
**GEAR PUMPS GROUP 2SP**
**2SP**

## DIMENSIONI ALBERO - SHAFT DIMENSIONS

**30**  
 Scanalato SAE  
 11T  
 SAE 11T  
 splined

Coppia 150 Nm  
 Torque 111 ft-lbs

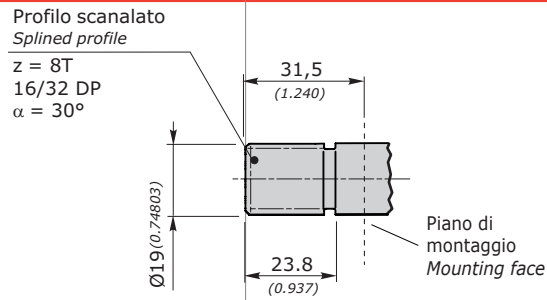

Disponibile per - available for: **SUPSAE**

**31**  
 Cilindrico SAE  
 SAE Parallel  
 shaft

Coppia 90 Nm  
 Torque 67 ft-lbs

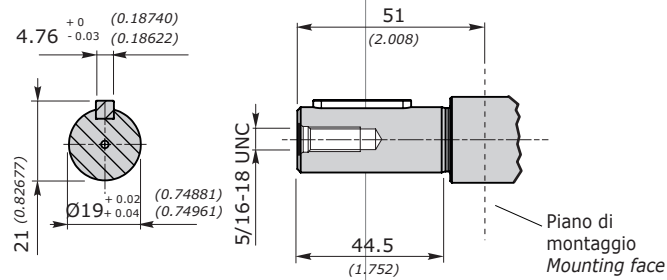

Disponibile per - available for: **SUPSAE**

**47**  
 Cilindrico Ø 22  
 Ø 22 Parallel  
 shaft

Coppia 110 Nm  
 Torque 81 ft-lbs

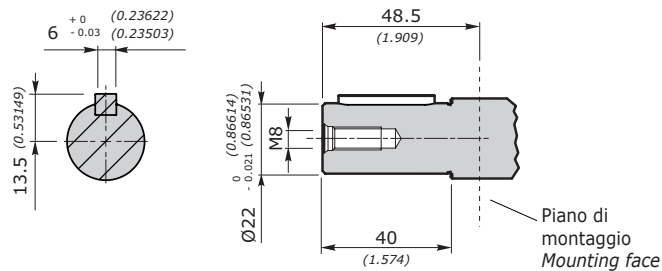

Disponibile per - available for: **SUPB80C**

**POMPE AD INGRANAGGI GRUPPO 2SP**  
**GEAR PUMPS GROUP 2SP**

**POSIZIONE CONNESSIONE • CONNECTION POSITION**

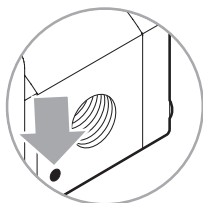
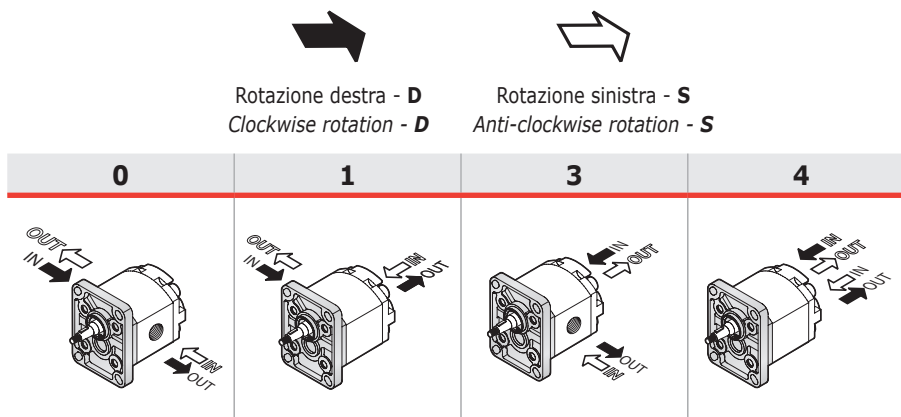

Il segno del corpo indica il lato aspirazione per le pompe  
 The sign on the body identifies the suction side for the pumps

**IN = ASPIRAZIONE - SUCTION**  
**OUT = MANDATA - DELIVERY**

**COPERCHIO STANDARD • STANDARD COVER**

Per posizione **0**  
 For position **0**

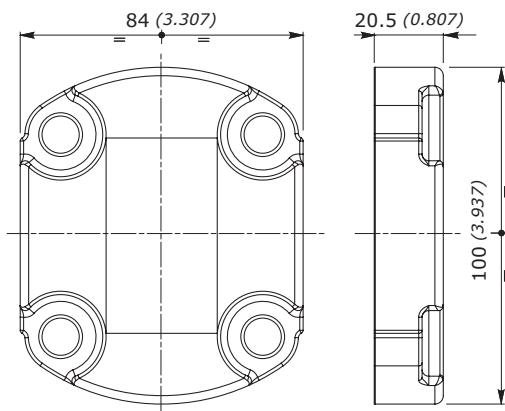

Per posizioni **1, 3, 4**  
 For position **1, 3, 4**

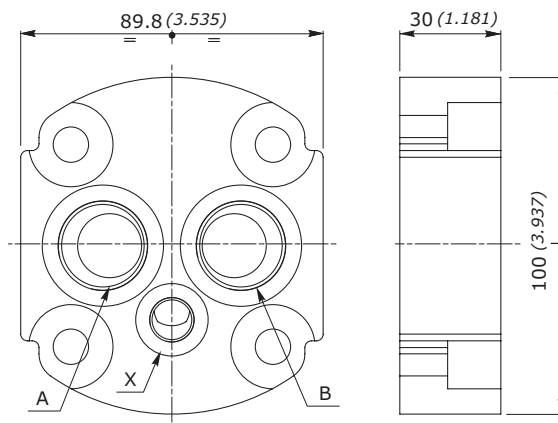

CONNESSIONI / CONNECTION			
	A	B	X
<b>GAS</b>	G 3/4	G 3/4	G 1/4
<b>SAE</b>	SAE 12	SAE 12	SAE 6

**POMPE AD INGRANAGGI GRUPPO 2SP**  
**GEAR PUMPS GROUP 2SP**
**TIPO CONNESSIONE • CONNECTION TYPE**

Le connessioni rappresentate corrispondono alle versioni standard; per connessioni differenti, contattare il nostro Ufficio Commerciale. *The connection types shown correspond to standard configuration; for different applications contact our Commercial Dept.*

<b>2SP</b>		POSIZIONE CONNESSIONE - CONNECTION POSITION			
		<b>0</b>	<b>1</b>	<b>3</b>	<b>4</b>
GAS	<b>G</b>	◇	◇	◇	◇
UNF	<b>U</b>	◇	◇	◇	◇
FLANGIATE FLANGED	<b>T</b>	◇			
	<b>N</b>	◇			
	<b>M</b>	◇			
	<b>F</b>	◇			

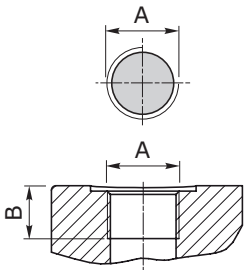
<b>GAS</b>	UNI ISO 228/1	SIGLA CODE	CIL. DISPL.	ASPIRAZIONE - SUCTION IN			MANDATA - DELIVERY OUT		
				<b>A</b>	<b>B</b>	↻	<b>A</b>	<b>B</b>	↻
		<b>G</b>	40	G 1/2"	16 [mm] 0.630 [inch]	50 [Nm] 443 [in.lbs]	G 1/2"	16 [mm] 0.630 [inch]	50 [Nm] 443 [in.lbs]
			60						
			80						
			110	G 3/4"	17 [mm] 0.670 [inch]	60 [Nm] 531 [in.lbs]			
			140						
			160						
			190						
			220						
			260						
			310						

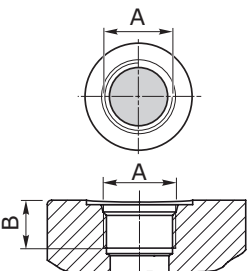
<b>UNF</b>	ANSI/ASME B1.1	SIGLA CODE	CIL. DISPL.	ASPIRAZIONE SUCTION IN			MANDATA DELIVERY OUT					
				<b>A</b>	<b>B</b>	↻	<b>A</b>	<b>B</b>	↻			
		<b>U</b>	40	SAE 10 7/8"-14 UNF	17 [mm] 0.670 [inch]	55 [Nm] 487 [in.lbs]	SAE 10 7/8"-14 UNF	17 [mm] 0.670 [inch]	55 [Nm] 487 [in.lbs]			
			60									
			80									
			110	SAE 12 1"1/16-12 UN	20 [mm] 0.788 [inch]	60 [Nm] 531 [in.lbs]						
			140									
			160									
			190									
			220									
			260									
			310									
			<b>W</b>			40	SAE 16 1"5/16-12 UN	20 [mm] 0.788 [inch]	70 [Nm] 620 [in.lbs]	SAE 12 1"1/16-12 UN	20 [mm] 0.788 [inch]	60 [Nm] 531 [in.lbs]
						60						
						80						
						110						
140												
160												
190												
220												
260												
310												

**POMPE AD INGRANAGGI GRUPPO 2SP**  
**GEAR PUMPS GROUP 2SP**

FLANGIATE FLANGED	ISO/R 262	SIGLA CODE	CIL. DISPL.	ASPIRAZIONE SUCTION IN					MANDATA DELIVERY OUT								
				A	B	C	D	↻	A	B	C	D	↻				
		T	40														
			60														
			80														
			110														
			140	20	40		15	8	15	35		15	8		15	8	
			160	[mm]	[mm]	M6	[mm]	[Nm]	[mm]	[mm]	M6	[mm]	[Nm]	[mm]	[mm]	[Nm]	
			190	0.787	1.575		0.591	71	0.591	1.378		0.591	71	0.591	1.378	0.591	71
			[inch]	[inch]		[inch]	[in.lbs]	[inch]	[inch]		[inch]	[in.lbs]	[inch]	[in.lbs]	[inch]	[in.lbs]	
			220														
			260														
310																	
		N	40	13	30		15	8									
			60	[mm]	[mm]	M6	[mm]	[Nm]									
			80	0.512	1.181		0.591	71									
			[inch]	[inch]		[inch]	[in.lbs]										
			110						13	30							
			140						[mm]	[mm]	M6	[mm]	[Nm]	[mm]	[mm]	[mm]	[Nm]
			160	19	40		14	15	0.512	1.181		0.512	1.181		0.591	71	
			190	[mm]	[mm]	M8	[mm]	[Nm]	[inch]	[inch]		[inch]	[inch]		[inch]	[in.lbs]	
			220	0.748	1.575		0.552	133							0.591	71	
			[inch]	[inch]		[inch]	[in.lbs]								[inch]	[in.lbs]	
260																	
310																	
		M	40	non disponibile not available					non disponibile not available								
			60	non disponibile not available					non disponibile not available								
			80	non disponibile not available					non disponibile not available								
			110														
			140														
			160	19	40		14	15	19	40		14	15		14	15	
			190	[mm]	[mm]	M8	[mm]	[Nm]	[mm]	[mm]	M8	[mm]	[Nm]	[mm]	[mm]	[Nm]	
			220	0.748	1.575		0.552	133	0.748	1.575		0.552	133		0.552	133	
			[inch]	[inch]		[inch]	[in.lbs]	[inch]	[inch]		[inch]	[in.lbs]	[inch]		[inch]	[in.lbs]	
			260														
310																	

FLANGIATE FLANGED	ISO/R 262	SIGLA CODE	CIL. DISPL.	ASPIRAZIONE SUCTION IN					MANDATA DELIVERY OUT								
				A	B	C	D	E	↻	A	B	C	D	E	↻		
		F*	40	20	17,4	38		15	8								
			60	[mm]	[mm]	[mm]	M6	[mm]	[Nm]								
			80	0.787	0.685	1.496		0.591	71								
			[inch]	[inch]	[inch]		[inch]	[in.lbs]									
			110						15	17,4	38						
			140						[mm]	[mm]	[mm]	M6	[mm]	[Nm]	[mm]	[mm]	[Nm]
			160	26	22,4	47,6		15	8	0.591	0.685	1.496		0.591	71	0.591	71
			190	[mm]	[mm]	[mm]	M6	[mm]	[Nm]	[inch]	[inch]	[inch]		[inch]	[in.lbs]	[inch]	[in.lbs]
			220	1.024	0.882	1.874		0.591	71								
			[inch]	[inch]	[inch]		[inch]	[in.lbs]									
260																	
310																	

\*: Le flange non corrispondono a norma SAEJ518. Flange a norma disponibili a richiesta, contattare il Servizio Commerciale.

\*: Flanges F do not correspond to SAEJ518. Flanges SAEJ518 available on request, please contact our Sales Dpt.

**POMPE AD INGRANAGGI GRUPPO 2SP**  
**GEAR PUMPS GROUP 2SP**
**OPZIONI • OPTIONS**
**VLPI**

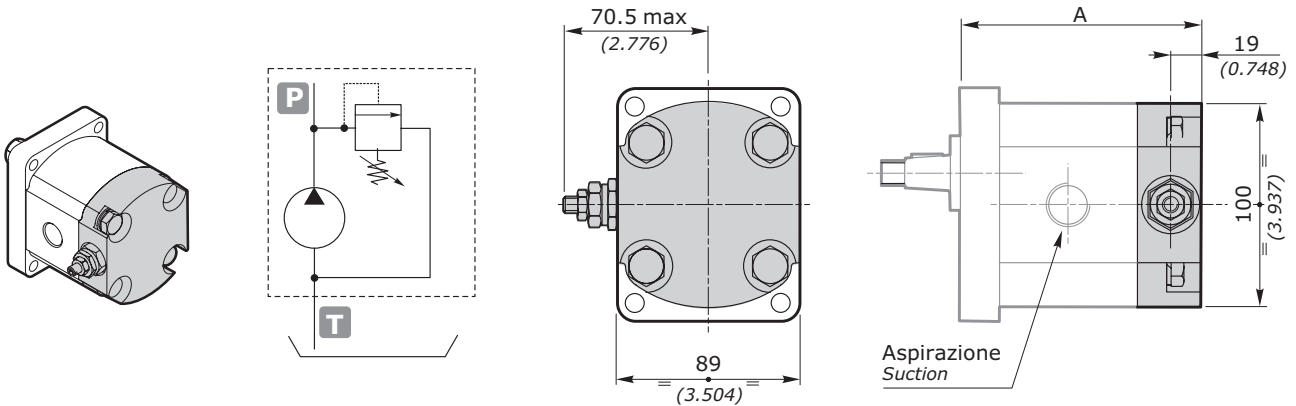
 VALVOLA LIMITATRICE DI PRESSIONE A SCARICO INTERNO  
 PRESSURE RELIEF VALVE WITH INTERNAL EXHAUST

GRUPPO GROUP 2	EUR-SAEA-B50C		A B80C		E52C	
	mm	inch	mm	inch	mm	inch
<b>2SP 040</b>	104.8	4.126	106.8	4.205	102.1	4.020
<b>2SP 060</b>	108.1	4.256	110.1	4.335	105.4	4.150
<b>2SP 080</b>	112.3	4.421	114.3	4.500	109.6	4.315
<b>2SP 110</b>	116.4	4.583	118.4	4.661	113.7	4.476
<b>2SP 140</b>	121.4	4.780	123.4	4.858	118.7	4.673
<b>2SP 160</b>	125.6	4.945	127.6	5.024	122.9	4.839
<b>2SP 190</b>	130.6	5.142	132.6	5.220	127.9	5.035
<b>2SP 220</b>	135.6	5.339	137.6	5.417	132.9	5.232
<b>2SP 260</b>	141.4	5.567	143.4	5.646	138.7	5.461
<b>2SP 310</b>	149.8	5.902	151.8	5.981	147.1	5.796

La valvola limitatrice di pressione si applica sostituendo il coperchio posteriore. Il corpo VLP è disponibile in alluminio. E' rappresentata una pompa con rotazione sinistra.

**L'apertura della valvola limitatrice di pressione deve avvenire per tempi non superiori ai 10 secondi ogni minuto, per evitare il surriscaldamento della pompa.**

*The pressure relief valve can be applied by substituting the rear cover. VLP cover is available in aluminum. The showed pump is with anticlockwise rotation.*

**The opening of the pressure relief valve should be carried out for times not over 10" each minute, to avoid the pump overheating.**

esempio • example: **2SP - A - 140 - D - EUR - B - N - 10 - 0 - G - VLPI (N 120)**

**VLPI** = Coperchio con VPL a scarico interno / Cover with VPL with internal exhaust

**N** = Tipo molla - vedi tabella / Spring type - see table

**120** = Taratura - vedi tabella / Setting - see table

TIPO - TYPE	CAMPI DI TARATURE - CALIBRATION FIELDS					
	molla bianca - white spring	B	molla nera - black spring	N	molla rossa - red spring	R
bar	30 ÷ 80		81 ÷ 200		201 ÷ 350	
psi	435 ÷ 1160		1175 ÷ 2900		2915 ÷ 5075	
STANDARD	70 bar (1015 psi)		150 bar (2175 psi)		250 bar (3625 psi)	

NOTA: In caso di omissione del valore di taratura, esso sarà inteso standard (vedi tabella).

NOTE: Without setting request, it will be considered standard (see table).

**POMPE AD INGRANAGGI GRUPPO 2SP**  
**GEAR PUMPS GROUP 2SP**

**VLPE** VALVOLA LIMITATRICE DI PRESSIONE A SCARICO ESTERNO  
 PRESSURE RELIEF VALVE WITH EXTERNAL EXHAUST

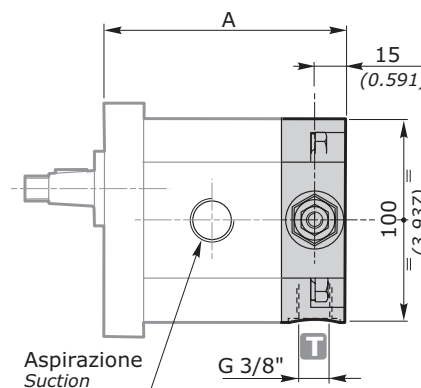
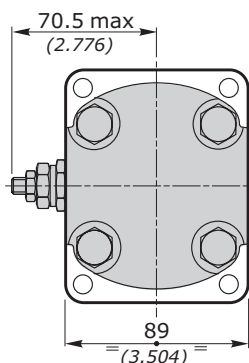
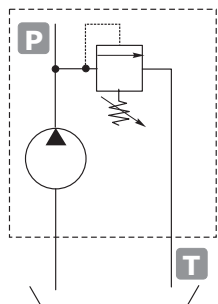
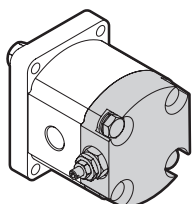

GRUPPO GROUP 2	EUR-SAEA-B50C		A B80C		E52C	
	mm	inch	mm	inch	mm	inch
<b>2SP 040</b>	100.8	3.969	102.8	4.047	98.1	3.862
<b>2SP 060</b>	104.1	4.098	106.1	4.177	101.4	3.992
<b>2SP 080</b>	108.3	4.264	110.3	4.343	105.6	4.157
<b>2SP 110</b>	112.4	4.425	114.4	4.504	109.7	4.319
<b>2SP 140</b>	117.4	4.622	119.4	4.701	114.7	4.516
<b>2SP 160</b>	121.6	4.787	123.6	4.866	118.9	4.681
<b>2SP 190</b>	126.6	4.984	128.6	5.063	123.9	4.878
<b>2SP 220</b>	131.6	5.181	133.6	5.260	128.9	5.075
<b>2SP 260</b>	137.4	5.409	139.4	5.488	134.7	5.303
<b>2SP 310</b>	145.8	5.745	147.8	5.823	143.1	5.638

La valvola limitatrice di pressione si applica sostituendo il coperchio posteriore. Il coperchio VLP è disponibile in alluminio. E' rappresentata una pompa con rotazione sinistra. Nelle pompe con rotazione destra, la valvola è dal lato opposto

*The pressure relief valve can be applied by substituting the rear cover. VLP cover is available in aluminum. The showed pump is with anticlockwise rotation. In the case of pumps with clockwise rotation, the valve is on the opposite side.*

esempio • example: **2SP - A - 140 - D - EUR - B - N - 10 - 0 - G - VLPE N 120**

**VLPE** = Coperchio con VPL a scarico esterno / Cover with VPL with external exhaust

**N** = Tipo molla - vedi tabella / Spring type - see table

**120** = Taratura - vedi tabella / Setting - see table

TIPO - TYPE	CAMPI DI TARATURE - CALIBRATION FIELDS					
	molla bianca - white spring	<b>B</b>	molla nera - black spring	<b>N</b>	molla rossa - red spring	<b>R</b>
bar	30 ÷ 80		81 ÷ 200		201 ÷ 350	
psi	435 ÷ 1160		1175 ÷ 2900		2915 ÷ 5075	
STANDARD	70 bar (1015 psi)		150 bar (2175 psi)		250 bar (3625 psi)	

NOTA: In caso di omissione del valore di taratura, esso sarà inteso standard (vedi tabella).

NOTE: Without setting request, it will be considered standard (see table).

**POMPE AD INGRANAGGI GRUPPO 2SP**  
**GEAR PUMPS GROUP 2SP**
**VRF**

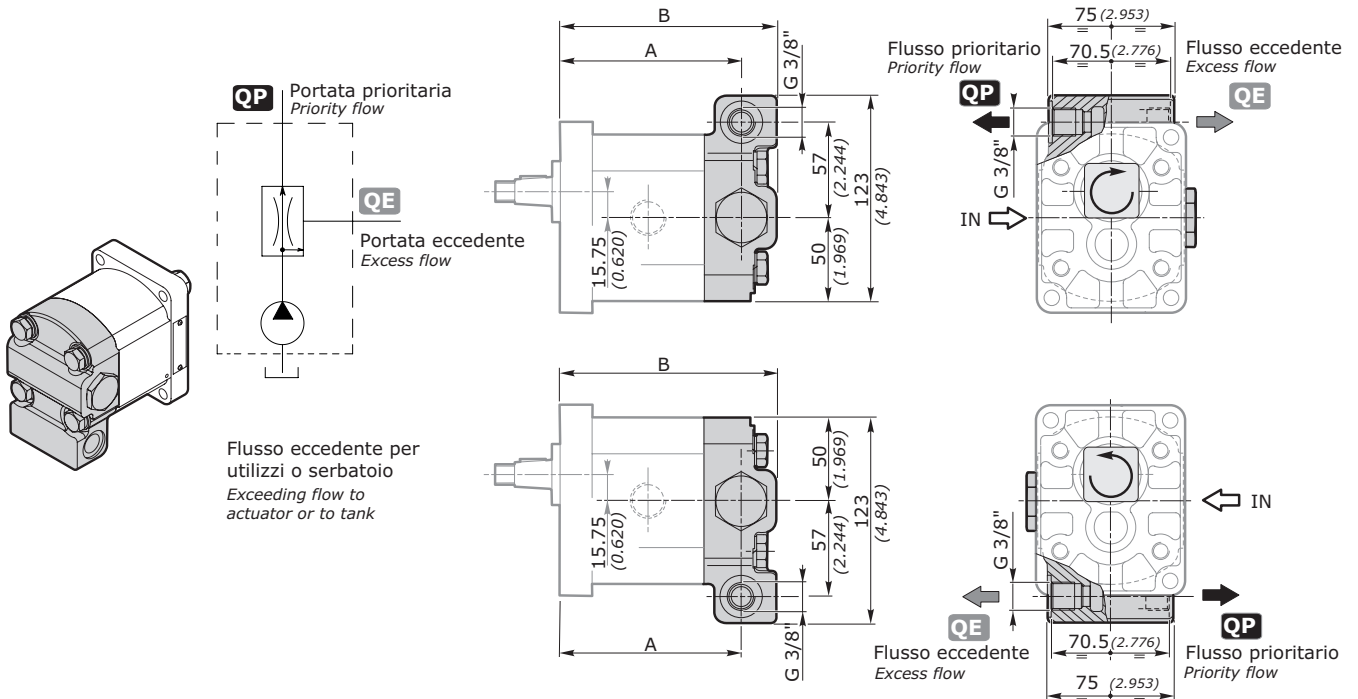
 VALVOLA REGOLATRICE DI FLUSSO  
 PRIORITY FLOW DIVIDER VALVE

GRUPPO GROUP 2	EUR - SAE - B50C		A B80C		E52C		EUR - SAE - B50C		B B80C		E52C	
	mm	inch	mm	inch	mm	inch	mm	inch	mm	inch	mm	inch
<b>2SP 040</b>	91.8	3.614	93.8	3.693	89.1	3.508	112.8	4.441	114.8	4.520	110.1	4.335
<b>2SP 060</b>	95.1	3.744	97.1	3.823	92.4	3.638	116.1	4.571	118.1	4.650	113.4	4.465
<b>2SP 080</b>	99.3	3.909	101.3	3.988	96.6	3.803	120.3	4.736	122.3	4.815	117.6	4.630
<b>2SP 110</b>	103.4	4.071	105.4	4.150	100.7	3.965	124.4	4.898	126.4	4.976	121.7	4.791
<b>2SP 140</b>	108.4	4.268	110.4	4.346	105.7	4.161	129.4	5.094	131.4	5.173	126.7	4.988
<b>2SP 160</b>	112.6	4.433	114.6	4.512	109.9	4.327	133.6	5.260	135.6	5.339	130.9	5.154
<b>2SP 190</b>	117.6	4.630	119.6	4.709	114.9	4.524	138.6	5.457	140.6	5.535	135.9	5.350
<b>2SP 220</b>	122.6	4.827	124.6	4.906	119.9	4.720	143.6	5.654	145.6	5.732	140.9	5.547
<b>2SP 260</b>	128.4	5.055	130.4	5.134	125.7	4.949	149.4	5.882	151.4	5.961	146.7	5.776
<b>2SP 310</b>	136.8	5.390	138.8	5.469	134.1	5.284	157.8	6.217	159.8	6.296	155.1	6.111

esempio • example:

**2SP - A - 140 - D - EUR - B - N - 10 - 0 - G - VRF 5**
**VRF** = Coperchio con VRF / Cover with VRF

**5** = portata prioritaria - vedi tabella / Priority flow - see table

VALORE VALUE	PORTATE - FLOWS	
	l/min	US gal/min
<b>5</b>	5	1.32
<b>7</b>	7	1.85
<b>8</b>	8	2.12
<b>11</b>	11	2.91
<b>14</b>	14	3.70
<b>21</b>	21	6.54



**POMPE AD INGRANAGGI GRUPPO 2SP**  
**GEAR PUMPS GROUP 2SP**

**VRFVLP**

VALVOLA REGOLATRICE DI FLUSSO E VALVOLA LIMITATRICE DI PRESSIONE (SCARICO INTERNO)  
PRIORITY FLOW DIVIDER VALVE AND PRESSURE RELIEF VALVE (INTERNAL EXHAUST)

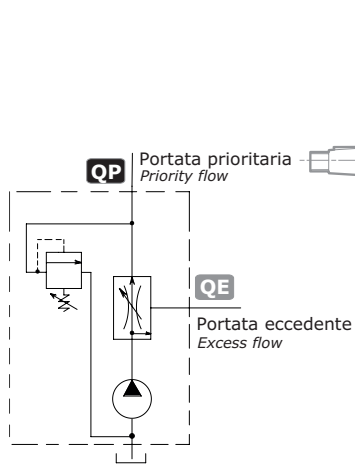
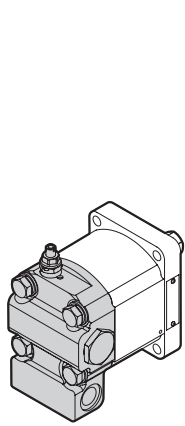

Flusso eccedente per utilizzi o serbatoio / Exceeding flow to actuator or to tank

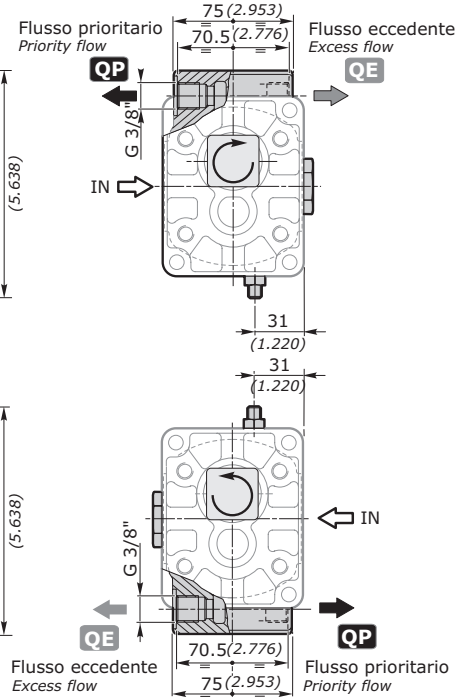
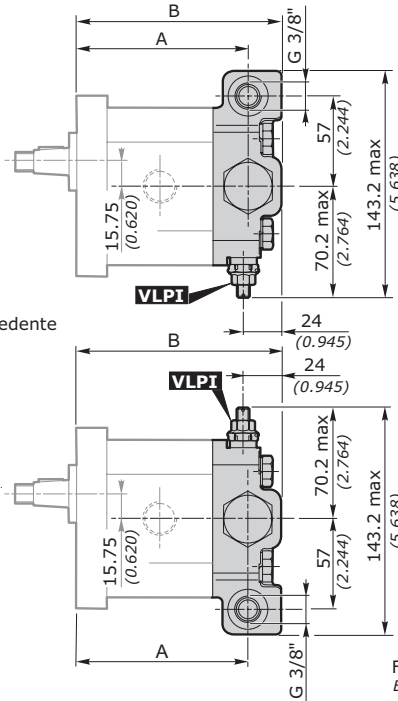

VALORE VALUE	PORTATE - FLOWS	
	l/min	US gal/min
5	5	1.32
7	7	1.85
8	8	2.12
11	11	2.91
14	14	3.70
21	21	6.54

GRUPPO GROUP 2	A						B					
	STD - SAE - B50C		B80C		E52C		STD - SAE - B50C		B80C		E52C	
	mm	inch	mm	inch	mm	inch	mm	inch	mm	inch	mm	inch
2SP 040	91.8	3.614	93.8	3.693	89.1	3.508	112.8	4.441	114.8	4.520	110.1	4.335
2SP 060	95.1	3.744	97.1	3.823	92.4	3.638	116.1	4.571	118.1	4.650	113.4	4.465
2SP 080	99.3	3.909	101.3	3.988	96.6	3.803	120.3	4.736	122.3	4.815	117.6	4.630
2SP 110	103.4	4.071	105.4	4.150	100.7	3.965	124.4	4.898	126.4	4.976	121.7	4.791
2SP 140	108.4	4.268	110.4	4.346	105.7	4.161	129.4	5.094	131.4	5.173	126.7	4.988
2SP 160	112.6	4.433	114.6	4.512	109.9	4.327	133.6	5.260	135.6	5.339	130.9	5.154
2SP 190	117.6	4.630	119.6	4.709	114.9	4.524	138.6	5.457	140.6	5.535	135.9	5.350
2SP 220	122.6	4.827	124.6	4.906	119.9	4.720	143.6	5.654	145.6	5.732	140.9	5.547
2SP 260	128.4	5.055	130.4	5.134	125.7	4.949	149.4	5.882	151.4	5.961	146.7	5.776
2SP 310	136.8	5.390	138.8	5.469	134.1	5.284	157.8	6.217	159.8	6.296	155.1	6.111

esempio • example: **2SP - A - 140 - D - EUR - B - N - 10 - G - VRF 5 VLPI (N 120)**

**VRF** = Coperchio con VRF / Cover with VRF

**5** = portata prioritaria - vedi tabella / Priority flow - see table

**VLPI** = Coperchio con VPL a scarico interno / Cover with VPL with internal exhaust

**N** = Tipo molla - vedi tabella / Spring type - see table

**120** = Taratura - vedi tabella / Setting - see table

TIPO - TYPE	CAMPI DI TARATURE - CALIBRATION FIELDS					
	molla bianca - white spring	B	molla nera - black spring	N	molla rossa - red spring	R
bar	30 ÷ 80		81 ÷ 200		201 ÷ 350	
psi	435 ÷ 1160		1175 ÷ 2900		2915 ÷ 5075	
STANDARD	70 bar (1015 psi)		150 bar (2175 psi)		250 bar (3625 psi)	

NOTA: In caso di omissione del valore di taratura, esso sarà inteso standard (vedi tabella).

NOTE: Without setting request, it will be considered standard (see table).

**POMPE AD INGRANAGGI GRUPPO 2SP**  
**GEAR PUMPS GROUP 2SP**
**UNLD**

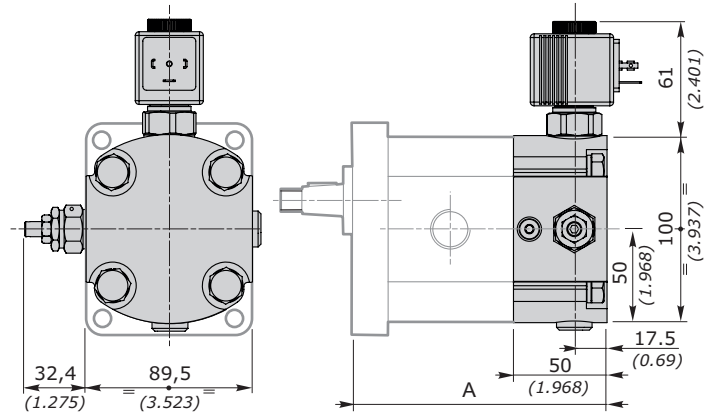
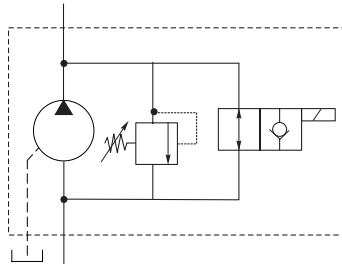
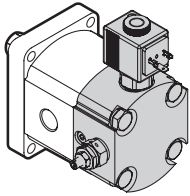
 VALVOLA UNLOADING  
 UNLOADING VALVE

GRUPPO GROUP 2	EUR-SAE B50C		A			
	mm	inch	B80C		E52C	
	mm	inch	mm	inch	mm	inch
<b>2SM 040</b>	123.8	4.874	125.8	4.952	121.1	4.767
<b>2SM 060</b>	127.1	5.003	129.1	5.082	124.4	4.897
<b>2SM 080</b>	131.3	5.169	133.3	5.248	128.6	5.062
<b>2SM 110</b>	135.4	5.330	137.4	5.409	132.7	5.224
<b>2SM 140</b>	140.4	5.527	142.4	5.606	137.7	5.421
<b>2SP 160</b>	144.6	5.692	146.6	5.771	141.9	5.586
<b>2SP 190</b>	149.6	5.889	151.6	5.968	146.9	5.793
<b>2SP 220</b>	154.6	6.086	156.6	6.165	151.9	5.980
<b>2SP 260</b>	160.4	6.314	162.4	6.393	157.7	6.208
<b>2SP 310</b>	168.8	6.645	170.8	6.724	166.1	6.539

 esempio • example: **2SP-A-140-D-EUR-B-N-10-0-T-NA(UNLD)-VLPI(N100)-12VDC**
**UNLD** = Coperchio con valvola unloading standard - Standard cover with unloading valve

**N** = Tipo molla - vedi tabella / Spring type - see table

**100** = Taratura - vedi tabella / Setting - see table

TIPO - TYPE	CAMPI DI TARATURE - CALIBRATION FIELDS								
	molla bianca - white spring		B	molla nera - black spring		N	molla rossa - red spring		R
bar	30 ÷ 80			81 ÷ 200			201 ÷ 350		
psi	435 ÷ 1160			1175 ÷ 2900			2915 ÷ 5075		
STANDARD	70 bar (1015 psi)			150 bar (2175 psi)			250 bar (3625 psi)		

NOTA: In caso di omissione del valore di taratura, esso sarà inteso standard (vedi tabella).

NOTE: Without setting request, it will be considered standard (see table).

**POMPE AD INGRANAGGI GRUPPO 2SP**  
**GEAR PUMPS GROUP 2SP**

**CP (LS)**

VALVOLA PRIORITARIA  
PRIORITY VALVE

Con questa valvola è necessario un ingranaggio condotto speciale

With this valve a special drive gear is needed

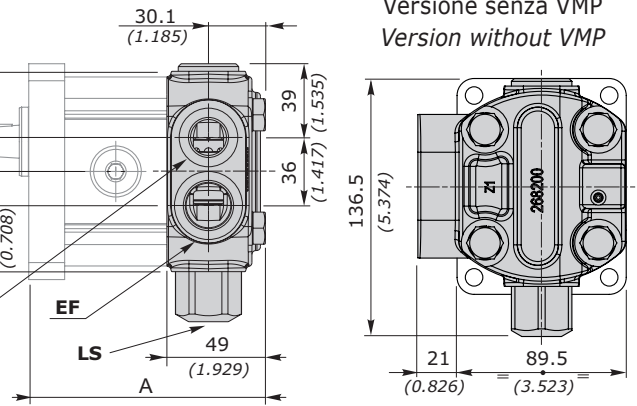
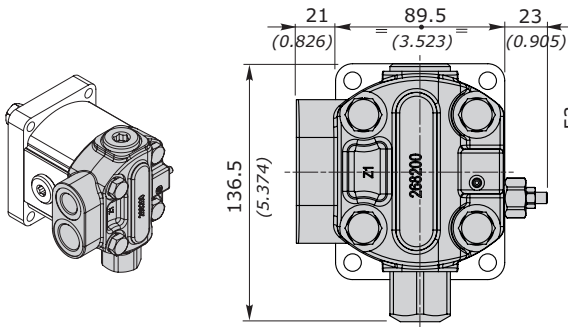

Versione senza VMP  
Version without VMP

COPERCIO / COVER							
1	2	3	4	5	6	7	8
CP	M	I	( 7 )	0.7	- 0.6 )	- VMP02	( 110 )
1	/ coperchio con valvola prioritaria - cover with priority valve						
2	posiz. bocche coperchio cover ports position			A	lato aspirazione corpo - body suction side		
				M	lato mandata corpo - body delivery side		
3	posizione bocca LS LS port position			I	sul lato inferiore del coperchio on bottom side of the cover		
				S	sul lato superiore del coperchio on upper side of the cover		
4	configurazione molla spring configuration			4	4 bar - 58 psi		
				7	7 bar - 101.5 psi		
				10	10 bar - 145 psi		
5	dimensione strozzatore tipo 2 type 2 orifice dimension			0.7	foro da 0.7 - 0.7 hole		
6	caratteristiche strozzatore tipo 3 type 3 orifice features			0.6	vedere la tabella sotto - see below		
7	VMP02 opzionale in pos. M optional VMP02, position M			VMP02	con valvola VMP02- with VMP02 valve		
				-	senza valvola VMP02- without VMP02 valve		
8	taratura VMP02 - VMP02 setting			110	110 bar - 1590 psi		

CONNESSIONI / CONNECTION			
	CF	EF	LS
GAS	G 1/2	G 3/4	G 1/4
SAE	SAE 8	SAE 10	SAE 4

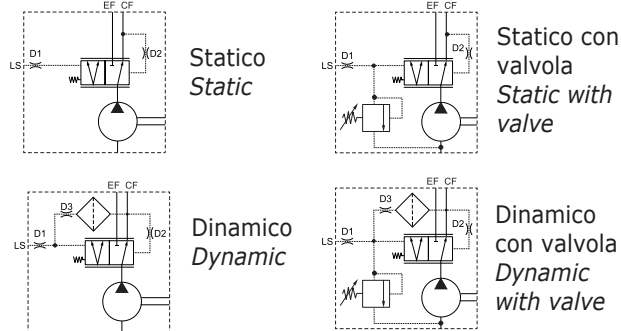

CARATTERISTICHE STROZZATORI TIPO 3 E MOLLA ORIFICES TYPE 3 FEATURES AND SPRING							
Pressione di Stand-By / Stand-By pressure							
mm	in	molla spring	5 l/min - 1.32 USgpm		80 l/min - 21.13 USgpm		
			bar	psi	bar	psi	
X	X	4	4	58	5	72.5	
0.5	0.019		5	72.5	6.5	94.2	
0.6	0.023		6	87	7.5	108.7	
0.7	0.027	7	7	101.5	10	145	
X	X		7	101.5	9	130.5	
0.5	0.019		9	130.5	11	159.5	
0.6	0.023	10	11	159.5	14	203	
0.7	0.027		14	203	18	261	
X	X		10	145	13	188.5	
0.5	0.019		12.5	181.2	16.5	239.2	
0.6	0.023		15.5	224.7	20	290	
0.7	0.027		20	290	26	377	

GRUPPO GROUP 2	A					
	EUR-SAE-A-B50C		B80C		E52C	
	mm	inch	mm	inch	mm	inch
2SP 040	123.3	4.854	125.3	4.933	120.6	4.748
2SP 060	126.6	4.984	128.6	5.062	123.9	4.877
2SP 080	130.8	5.149	132.8	5.228	128.1	5.043
2SP 110	134.9	5.311	136.9	5.389	132.2	5.204
2SP 140	139.9	5.507	141.9	5.586	137.2	5.401
2SP 160	144.1	5.673	146.1	5.751	141.4	5.566
2SP 190	149.1	5.870	151.1	5.948	146.4	5.763
2SP 220	154.1	6.067	156.1	6.145	151.4	5.960
2SP 260	159.9	6.295	161.9	6.374	157.2	6.188
2SP 310	168.3	6.625	170.3	6.704	165.6	6.519

X= statico / static

esempio • example: **2SP - A - 140 - D - EUR - B - N - 10 - G - CPMI (7\0.7-0.6) - VMP02(110)**

CP = Coperchio con valvola prioritaria / Cover with priority valve

7 = Tipo molla - vedi tabella / Spring type - see table

110 = Taratura - vedi tabella / Setting - see table

TIPO - TYPE	CAMPI DI TARATURE - CALIBRATION FIELDS		
	TV	TS	TR
bar	5 ÷ 80	50 ÷ 220	180 ÷ 350
psi	72 ÷ 1160	725 ÷ 3190	2610 ÷ 5075
STANDARD	70 bar (1015 psi)	150 bar (2175 psi)	250 bar (3625 psi)

NOTA: In caso di omissione del valore di taratura, esso sarà inteso standard (vedi tabella).

NOTE: Without setting request, it will be considered standard (see table).

**POMPE AD INGRANAGGI GRUPPO 2SP**  
**GEAR PUMPS GROUP 2SP**
**VA**

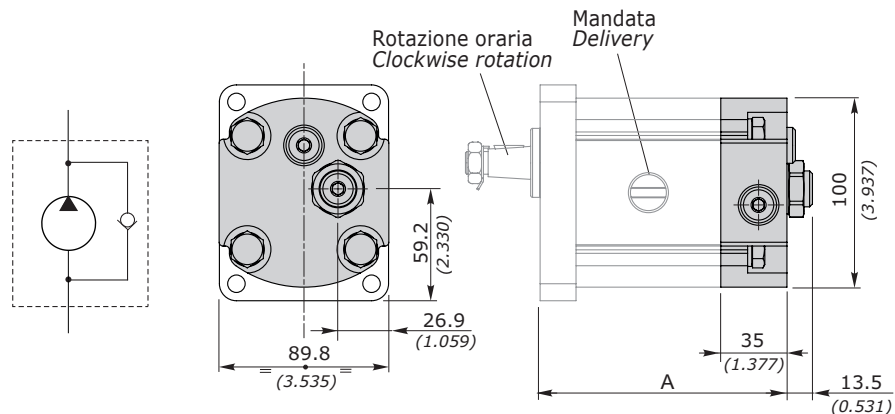
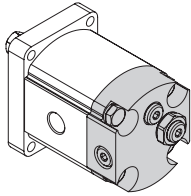
 VALVOLA ANTICAVITAZIONE  
 ANTICAVITATION VALVE

GRUPPO GROUP 2	EUR-SAEA-B50C		A B80C		E52C	
	mm	inch	mm	inch	mm	inch
<b>2SP 040</b>	109.3	4.303	111.3	4.381	106.6	4.196
<b>2SP 060</b>	112.6	4.433	114.6	4.511	109.9	4.326
<b>2SP 080</b>	116.8	4.598	118.8	4.677	114.1	4.492
<b>2SP 110</b>	120.9	4.759	122.9	4.838	118.2	4.653
<b>2SP 140</b>	125.9	4.956	127.9	5.035	123.2	4.850
<b>2SP 160</b>	130.1	5.122	132.1	5.200	127.4	5.015
<b>2SP 190</b>	135.1	5.318	137.1	5.397	132.4	5.212
<b>2SP 220</b>	140.1	5.515	142.1	5.594	137.4	5.409
<b>2SP 260</b>	145.9	5.744	147.9	5.822	143.2	5.637
<b>2SP 310</b>	154.3	6.074	156.3	6.153	151.6	5.968

esempio • example:

**2SP - A - 110 - D - EUR - H - N - 10 - G - VA**
**D** = Rotazione destra / Clockwise rotation

**S** = Rotazione sinistra / Anticlockwise rotation

**D(R)** = Reversibile, montata unidirezionale e valvola come motore destro  
 Reversible, mounted as clockwise rotation and valve as right gear motor

**S(R)** = Reversibile, montata unidirezionale e valvola come motore sinistro  
 Reversible, mounted as anticlockwise rotation and valve as left gear motor

**R...VA(D)/VA(S)** = Reversibile / Reversible

**VA** = Coperchio con valvola anticavitazione / Cover with anticavitation valve

**R...VA(D)** = Valvola montata come motore destro / Valve mounted as right gear motor

**R...VA(S)** = Valvola montata come motore sinistro / Valve mounted as left gear motor

NOTA: Nell'esempio viene descritta una pompa a rotazione destra con valvola anticavitazione montata come pompa destra, per altre configurazioni contattare il Servizio Commerciale

NOTE: in the example is represented gear pump with clockwise rotation and anticavitation valve mounted as right gear pump. For other configurations please contact our Sales Dpt.

**POMPE AD INGRANAGGI GRUPPO 2SP**  
**GEAR PUMPS GROUP 2SP**

**VMA**

VALVOLA ANTICAVITAZIONE E ANTIURTO  
 ANTICAVITATION AND ANTISHOCK VALVE

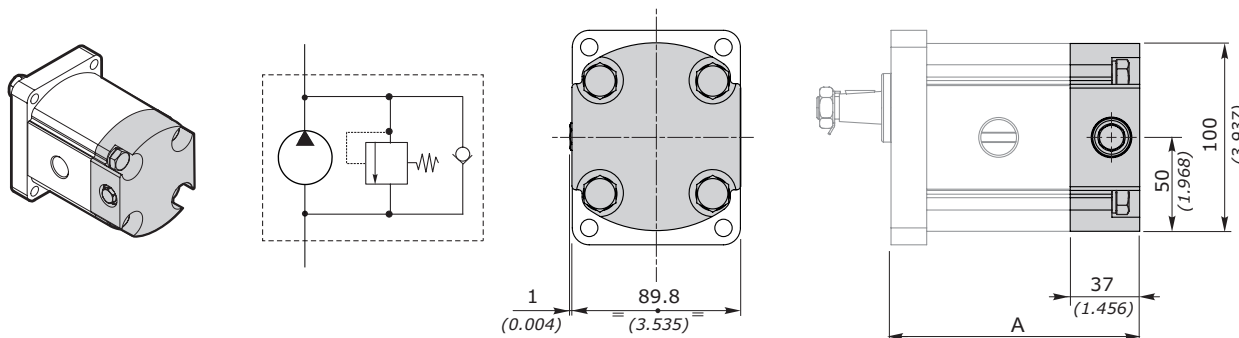

GRUPPO GROUP 2	EUR-SAE-B50C		A B80C		E52C	
	mm	inch	mm	inch	mm	inch
<b>2SP 040</b>	111.3	4.381	113.3	4.450	108.6	4.275
<b>2SP 060</b>	114.6	4.511	116.6	4.590	111.9	4.405
<b>2SP 080</b>	118.8	4.677	120.8	4.755	116.1	4.570
<b>2SP 110</b>	122.9	4.838	124.9	4.917	120.2	4.732
<b>2SP 140</b>	127.9	5.035	129.9	5.114	125.2	4.929
<b>2SP 160</b>	132.1	5.200	134.1	5.279	129.4	5.094
<b>2SP 190</b>	137.1	5.397	139.1	5.476	134.4	5.291
<b>2SP 220</b>	142.1	5.594	144.1	5.673	139.4	5.488
<b>2SP 260</b>	147.9	5.822	149.9	5.901	145.2	5.716
<b>2SP 310</b>	156.3	6.153	158.3	6.232	153.6	6.047

esempio • example: **2SP - A - 140 - D - EUR - B - N - 10 - G - VMA**

**VMA** = Coperchio con valvola anticavitazione / Cover with anticavitation valve

VALVOLE ANTICAVITAZIONE A TARATURA FISSA - FIXED SETTING ANTICAVITATION VALVES																			
bar	50	63	80	100	110	125	140	150	160	175	190	200	210	230	240	250	260	270	280
psi	725	914	1150	1450	1590	1800	2050	2150	2300	2550	2750	2900	3050	3350	3500	3600	3750	3900	4050

taratura riferita a 10 l/min / setting is referred to 2.6 US gpm

NOTA: In caso di omissione del valore di taratura, esso sarà inteso standard.

NOTE: Without setting request, it will be considered standard.

**POMPE AD INGRANAGGI GRUPPO 3GP**  
**GEAR PUMPS GROUP 3GP**
**FLANGIA EUROPEA EUR EUROPEAN FLANGE**
**FLANGIA E COPERCHIO IN GHISA - CAST IRON FLANGE AND COVER**

GRUPPO GROUP 3GP	CILINDRATA DISPLACEMENT		PRESSIONE MAX - MAX PRESSURE						VELOCITÀ MAX MAX SPEED	PORTATA MAX MAX FLOW		VELOCITÀ MIN MIN SPEED
	cm <sup>3</sup> /giro	in <sup>3</sup> /rev	P1		P2		P3			l/min	Gal/ min	
			bar	psi	bar	psi	bar	psi	giri/min - rpm			giri/min - rpm
<b>3GP 190</b>	19.3	1.2	250	3625	265	3840	280	4260	3500	67.6	17.84	600
<b>3GP 230</b>	23.0	1.4	250	3625	265	3840	280	4060	3500	80.3	21.22	600
<b>3GP 300</b>	30.2	1.8	240	3480	255	3695	270	3915	3300	99.7	26.33	600
<b>3GP 340</b>	33.8	2.1	240	3480	255	3695	270	3915	3300	111.6	29.49	600
<b>3GP 370</b>	37.5	2.3	230	3335	245	3550	260	3770	3300	123.6	32.66	600
<b>3GP 440</b>	44.6	2.7	220	3190	235	3405	250	3625	3000	133.8	35.35	600
<b>3GP 530</b>	53.0	3.2	210	3045	225	3262	240	3480	3000	159.1	42.04	600
<b>3GP 620</b>	62.7	3.8	190	2755	200	2900	210	3045	2500	156.8	41.41	600
<b>3GP 700</b>	70.5	4.3	180	2610	190	2755	200	2900	2500	176.3	46.58	600
<b>3GP 770</b>	77.2	4.7	170	2465	180	2610	190	2755	2200	169.8	44.84	600

Nota - Per valori di pressione superiori a quelli indicati contattare il Servizio Commerciale.  
 Note - for higher pressure values please contact our Sales Dept.

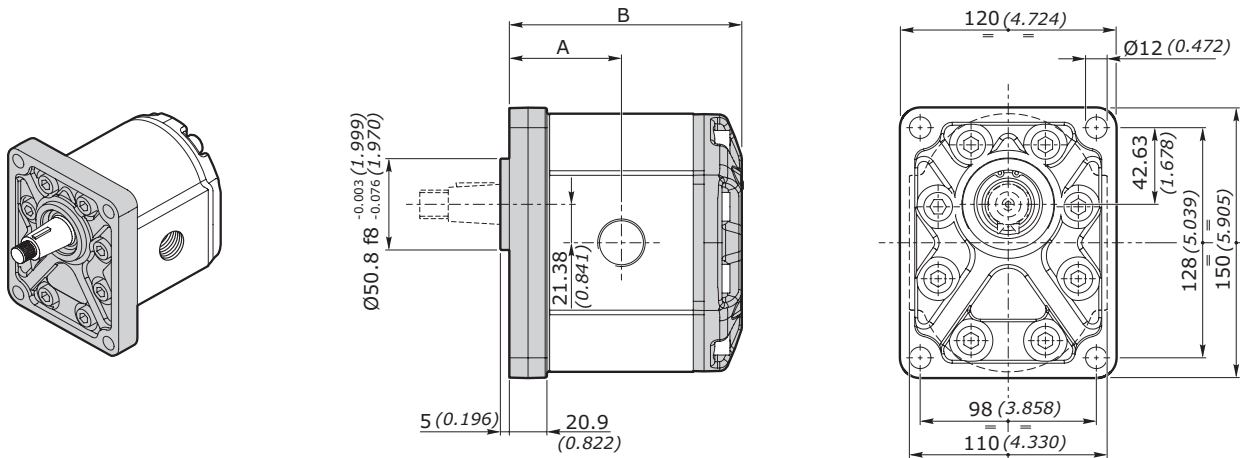
**DIMENSIONI • DIMENSIONS**

GRUPPO - GROUP 3	A		B		MASSA - MASS	
	mm	inch	mm	inch	kg	lbs
<b>3GP 190</b>	62.4	2.456	128.3	5.051	7.67	16.91
<b>3GP 230</b>	63.9	2.515	131.3	5.169	7.81	17.21
<b>3GP 300</b>	66.9	2.633	137.3	5.405	8.09	17.82
<b>3GP 340</b>	68.4	2.692	140.3	5.523	8.22	18.12
<b>3GP 370</b>	69.9	2.751	143.3	5.641	8.36	18.43
<b>3GP 440</b>	72.9	2.870	149.3	5.877	8.64	19.04
<b>3GP 530</b>	76.4	3.007	156.3	6.153	8.96	19.75
<b>3GP 620</b>	80.4	3.165	164.3	6.468	9.33	20.56
<b>3GP 700</b>	86.9	3.421	170.8	6.724	9.63	21.22
<b>3GP 770</b>	92.4	3.637	176.3	6.940	9.88	21.77

**POMPE AD INGRANAGGI GRUPPO 3GP**  
**GEAR PUMPS GROUP 3GP**

**FLANGIA SAE SAEB-SAEBOR SAE FLANGE**

**FLANGIA E COPERCHIO IN GHISA - CAST IRON FLANGE AND COVER**

GRUPPO GROUP 3GP	CILINDRATA DISPLACEMENT		PRESSIONE MAX - MAX PRESSURE						VELOCITÀ MAX MAX SPEED	PORTATA MAX MAX FLOW		VELOCITÀ MIN MIN SPEED
	cm <sup>3</sup> /giro	in <sup>3</sup> /rev	P1		P2		P3			l/min	Gal/min	
			bar	psi	bar	psi	bar	psi	giri/min - rpm			giri/min - rpm
<b>3GP 190</b>	19.3	1.2	250	3625	265	3840	280	4260	3500	67.6	17.84	600
<b>3GP 230</b>	23.0	1.4	250	3625	265	3840	280	4060	3500	80.3	21.22	600
<b>3GP 300</b>	30.2	1.8	240	3480	255	3695	270	3915	3300	99.7	26.33	600
<b>3GP 340</b>	33.8	2.1	240	3480	255	3695	270	3915	3300	111.6	29.49	600
<b>3GP 370</b>	37.5	2.3	230	3335	245	3550	260	3770	3300	123.6	32.66	600
<b>3GP 440</b>	44.6	2.7	220	3190	235	3405	250	3625	3000	133.8	35.35	600
<b>3GP 530</b>	53.0	3.2	210	3045	225	3262	240	3480	3000	159.1	42.04	600
<b>3GP 620</b>	62.7	3.8	190	2755	200	2900	210	3045	2500	156.8	41.41	600
<b>3GP 700</b>	70.5	4.3	180	2610	190	2755	200	2900	2500	176.3	46.58	600
<b>3GP 770</b>	77.2	4.7	170	2465	180	2610	190	2755	2200	169.8	44.84	600

Nota - Per valori di pressione superiori a quelli indicati contattare il Servizio Commerciale.  
Note - for higher pressure values please contact our Sales Dpt.

**DIMENSIONI • DIMENSIONS**

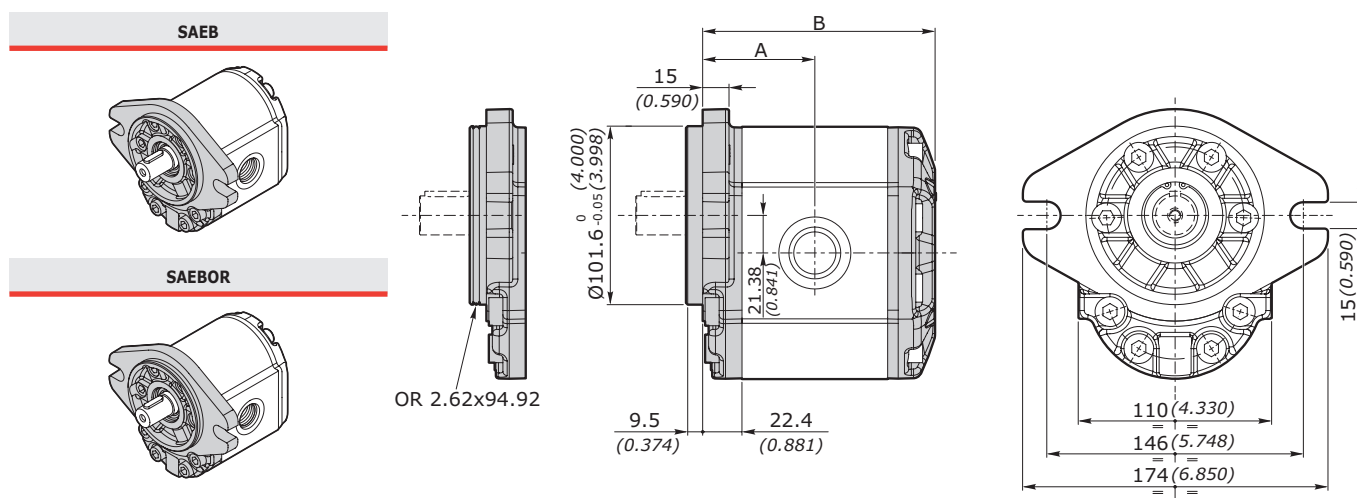

GRUPPO - GROUP 3	A		B		MASSA - MASS	
	mm	inch	mm	inch	kg	lbs
<b>3GP 190</b>	62.4	2.456	128.3	5.051	7.67	16.91
<b>3GP 230</b>	63.9	2.515	131.3	5.169	7.81	17.21
<b>3GP 300</b>	66.9	2.633	137.3	5.405	8.09	17.82
<b>3GP 340</b>	68.4	2.692	140.3	5.523	8.22	18.12
<b>3GP 370</b>	69.9	2.751	143.3	5.641	8.36	18.43
<b>3GP 440</b>	72.9	2.870	149.3	5.877	8.64	19.04
<b>3GP 530</b>	76.4	3.007	156.3	6.153	8.96	19.75
<b>3GP 620</b>	80.4	3.165	164.3	6.468	9.33	20.56
<b>3GP 700</b>	86.9	3.421	170.8	6.724	9.63	21.22
<b>3GP 770</b>	92.4	3.637	176.3	6.940	9.88	21.77

**POMPE AD INGRANAGGI GRUPPO 3GP**  
**GEAR PUMPS GROUP 3GP**
**FLANGIA ZFC FLANGE**
**FLANGIA E COPERCHIO IN GHISA - CAST IRON FLANGE AND COVER**

GRUPPO GROUP 3GP	CILINDRATA DISPLACEMENT		PRESSIONE MAX - MAX PRESSURE						VELOCITÀ MAX MAX SPEED	PORTATA MAX MAX FLOW		VELOCITÀ MIN MIN SPEED
	cm <sup>3</sup> /giro	in <sup>3</sup> /rev	P1		P2		P3			l/min	Gal/ min	
			bar	psi	bar	psi	bar	psi	giri/min - rpm			giri/min - rpm
<b>3GP 190</b>	19.3	1.2	250	3625	265	3840	280	4260	3500	67.6	17.84	600
<b>3GP 230</b>	23.0	1.4	250	3625	265	3840	280	4060	3500	80.3	21.22	600
<b>3GP 300</b>	30.2	1.8	240	3480	255	3695	270	3915	3300	99.7	26.33	600
<b>3GP 340</b>	33.8	2.1	240	3480	255	3695	270	3915	3300	111.6	29.49	600
<b>3GP 370</b>	37.5	2.3	230	3335	245	3550	260	3770	3300	123.6	32.66	600
<b>3GP 440</b>	44.6	2.7	220	3190	235	3405	250	3625	3000	133.8	35.35	600
<b>3GP 530</b>	53.0	3.2	210	3045	225	3262	240	3480	3000	159.1	42.04	600
<b>3GP 620</b>	62.7	3.8	190	2755	200	2900	210	3045	2500	156.8	41.41	600
<b>3GP 700</b>	70.5	4.3	180	2610	190	2755	200	2900	2500	176.3	46.58	600
<b>3GP 770</b>	77.2	4.7	170	2465	180	2610	190	2755	2200	169.8	44.84	600

Nota - Per valori di pressione superiori a quelli indicati contattare il Servizio Commerciale.  
 Note - for higher pressure values please contact our Sales Dpt.

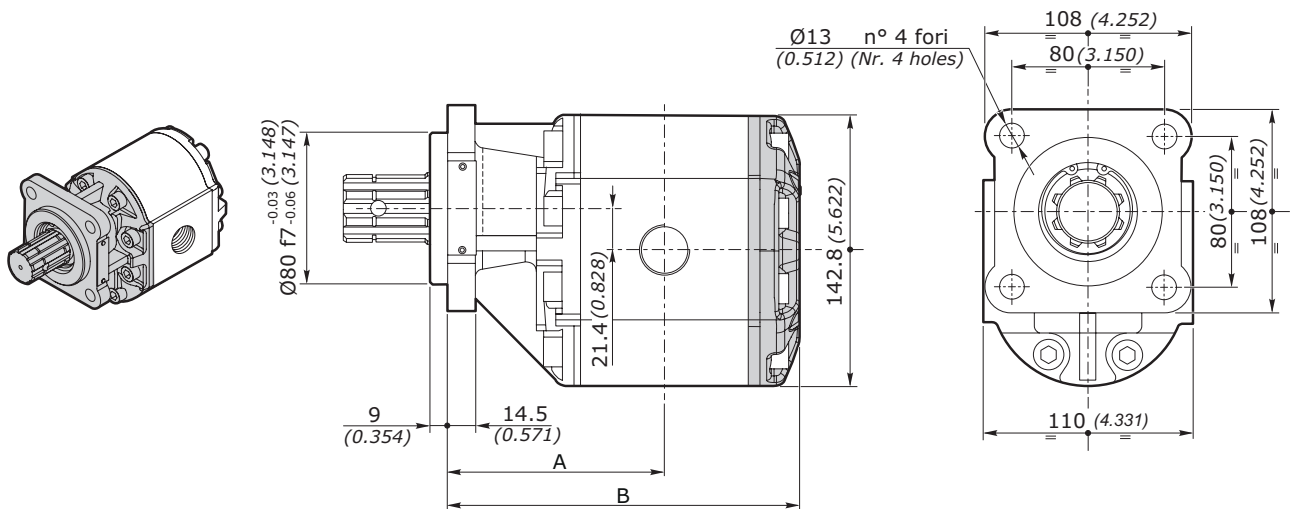
**DIMENSIONI • DIMENSIONS**

GRUPPO - GROUP 3	A		B		MASSA - MASS	
	mm	inch	mm	inch	kg	lbs
<b>3GP 190</b>	110.5	4.350	177.4	6.984	7.67	16.91
<b>3GP 230</b>	112.0	4.409	180.4	7.102	7.81	17.21
<b>3GP 300</b>	115.0	4.527	186.4	7.338	8.09	17.82
<b>3GP 340</b>	116.5	4.586	189.4	7.456	8.22	18.12
<b>3GP 370</b>	118.0	4.645	192.4	7.574	8.36	18.43
<b>3GP 440</b>	121.0	4.763	198.4	7.811	8.64	19.04
<b>3GP 530</b>	124.5	4.901	205.4	8.086	8.96	19.75
<b>3GP 620</b>	128.5	5.059	213.4	8.401	9.33	20.56
<b>3GP 700</b>	131.7	5.185	219.9	8.657	9.63	21.22
<b>3GP 770</b>	134.5	5.295	225.4	8.874	9.88	21.77



**POMPE AD INGRANAGGI GRUPPO 3GP**  
**GEAR PUMPS GROUP 3GP**

**CODICE ORDINAZIONE • ORDER CODE**

**3GP - G - 340 - D - EUR - B - N - 10 - 0 - G**

SIGLA - CODE	TIPO - TYPE	DESCRIZIONE - DESCRIPTION	PAGINA - PAGE
<b>3GP</b>	Tipo pompa <i>Pump type</i>	Pompa singola gruppo 3 <i>Single pump group 3</i>	6
<b>G</b>	Materiale flangia e coperchio <i>Flange and cover material</i>	<b>G</b> = Ghisa / <i>Cast iron</i>	72
<b>340</b>	Cilindrata <i>Displacement</i>	Cilindrata = 33.8 cm <sup>3</sup> /giro <i>Displacement = 2.1 in<sup>3</sup>/rev</i>	6
<b>D</b>	Senso di rotazione <i>Rotation wise</i>	<b>D</b> = Rotazione destra / <i>Clockwise rotation</i> <b>S</b> = Rotazione sinistra / <i>Anticlockwise rotation</i> <b>R</b> = Reversibile / <i>Reversible</i>	8
<b>EUR</b>	Tipo Flangia <i>Flange type</i>	Flangia standard europea <i>European standard flange</i>	72
<b>B</b>	Tipo anello di tenuta <i>Seal ring type</i>	Vedi tabella compatibilità <i>See compatibility table</i>	
<b>N</b>	Tipo guarnizione <i>Gasket type</i>	<b>N</b> = NBR <b>V</b> = Viton	73
<b>10</b>	Tipo Albero <i>Shaft type</i>	Vedi tabella compatibilità <i>See compatibility table</i>	
<b>0</b>	Posizione connessione <i>Connection position</i>	Vedi tabella compatibilità <i>See compatibility table</i>	75
<b>G</b>	Tipo connessione <i>Connection type</i>	Vedi tabella compatibilità <i>See compatibility table</i>	



**VERSIONI CON DOPPIO PARAOLIO • DOUBLE SHAFT SEAL VERSION**

Disponibili versioni con doppio paraolio per EUR, SAEB, SAEBOR.

Available versions with double shaft seal for EUR, SAEB, SAEBOR.

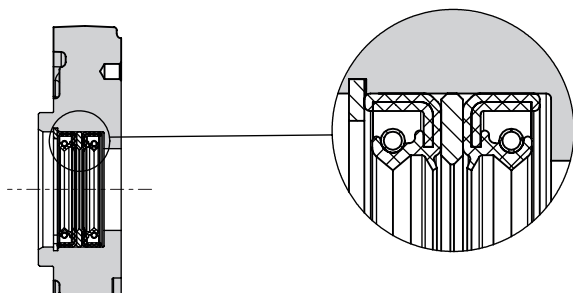

esempio • example:

**3GP - G - 340 - D - EUR2 - B - N - 10 - 0 - F**

**EUR2**= Doppio paraolio / *Double Shaft Seal*

Nota - La versione con paraolio è fornita con anelli a bassa pressione o alta pressione tipo K (vedi pag. 72).

Note - The version with shaft seal is supplied with K rings type with low pressure or high pressure (see page 72).

**POMPE AD INGRANAGGI GRUPPO 3GP**  
**GEAR PUMPS GROUP 3GP**
**TIPOLOGIA FLANGIA • FLANGE TYPE**

	EUR	SAEB*	SAEBOR	ZFC
<b>3GP</b>				
<b>A</b> alluminio aluminium	non disponibile not available	non disponibile not available	non disponibile not available	non disponibile not available
<b>G</b> ghisa cast iron	◇	◇	◇	◇

◇ = Combinazione standard - Standard combination

\* Contattare il servizio commerciale. / Available soon. Please contact our Sales Dpt.

**ANELLO DI TENUTA • SEAL RING**

SIGLA - CODE	TIPO - TYPE	DIAGRAMMA - DIAGRAM
<b>B</b>	Anello di tenuta fino a <b>3 bar</b> Sealing ring up to <b>3 bar</b>	
<b>H</b>	Anello di tenuta fino a <b>8 bar</b> Sealing ring up to <b>8 bar</b>	
<b>K</b>	Anello di tenuta fino a <b>30 bar</b> Sealing ring up to <b>30 bar</b>	

**POMPE AD INGRANAGGI GRUPPO 3GP**  
**GEAR PUMPS GROUP 3GP**

**COMBINAZIONE FLANGIA - ANELLO DI TENUTA - GUARNIZIONE • FLANGE - SEAL RING - GASKET COMBINATION**

3GP		EUR			SAEB*			SAEBOR			ZFC
		Anello - seal ring			Anello - seal ring			Anello - seal ring			Anello - seal ring
		B	H	K	B	H	K	B	H	K	B
NBR	<b>N</b>	◇	◇	◇	◇	◇	◇	◇	◇	◇	◇
Viton	<b>V</b>	●	●	●	●	●	●	●	●	●	●

esempio • example: **3GP - G - 340 - D - EUR - B - N - 10 - 0 - G**

**EUR** = Flangia europea / *European flange*

**B** = Anello tenuta fino a 3 bar / *Seal ring up to 3 bar*

**N** = Guarnizione in NBR / *NBR o-ring*

**COMBINAZIONE ALBERO - FLANGIA • SHAFT - FLANGE COMBINATION**

3GP		EUR	SAEB*	SAEBOR	ZFC
<b>10</b> Conico 1:8 <i>Tapered 1:8</i>	◇	●	●		
<b>13</b> Cilindrico SAEB <i>SAEB Parallel shaft</i>	●	◇	◇		
<b>14</b> Scanalato SAEB 13T (38.2) <i>SAEB 13T splined (38.2)</i>	●	◇	◇		
<b>14R</b> Scanalato SAEB 13T (44.7) <i>SAEB 13T splined (44.7)</i>	●	●	●		
<b>24</b> Scanalato UNI8953 <i>UNI8953 Splined</i>				◇	

◇ = Combinazione standard - *Standard combination*

● = Combinazione disponibile - *Available combination*

\* Contattare il servizio commerciale. / *Available soon. Please contact our Sales Dpt.*

**POMPE AD INGRANAGGI GRUPPO 3GP**  
**GEAR PUMPS GROUP 3GP**
**3GP**

## DIMENSIONI ALBERO - SHAFT DIMENSIONS

**10**

 Conico 1:8  
 Tapered 1:8

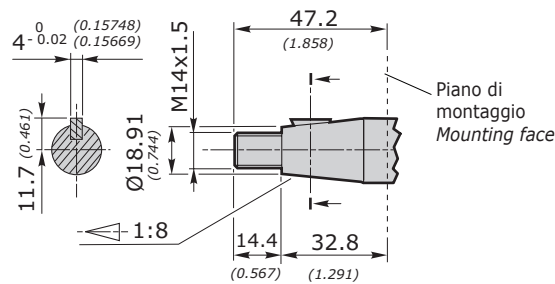
 Coppia 240 Nm  
 Torque 178 ft-lbs

 Disponibile per - available for: **EUR - SAEB - SAEBOR**
**13**

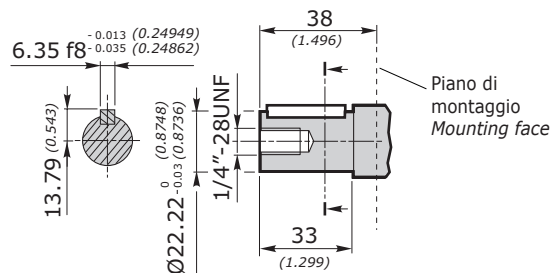
 Cilindrico SAEB  
 SAEB Parallel shaft

 Coppia 200 Nm  
 Torque 148 ft-lbs

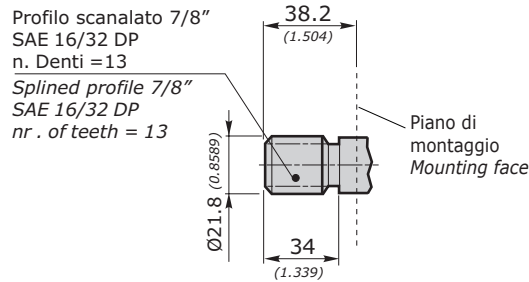
 Disponibile per - available for: **EUR - SAEB - SAEBOR**
**14**

 Scanalato SAEB  
 13T (38.2)  
 SAEB 13T  
 splined (38.2)

 Coppia 270 Nm  
 Torque 200 ft-lbs

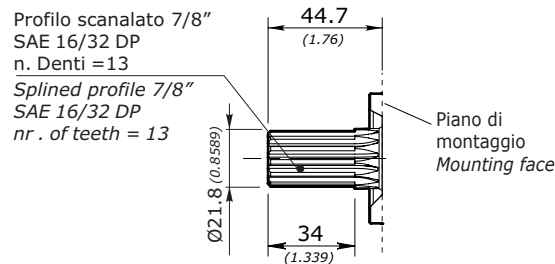
 Disponibile per - available for: **EUR - SAEB - SAEBOR**
**14R**

 Scanalato SAEB  
 13T (44.7)  
 SAEB 13T  
 splined (44.7)

 Coppia 270 Nm  
 Torque 200 ft-lbs

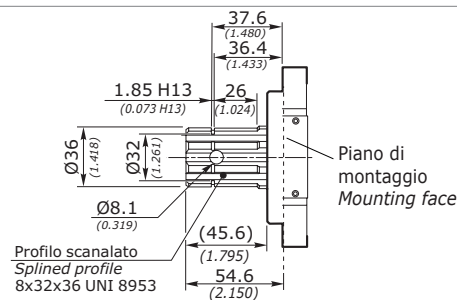
 Disponibile per - available for: **EUR - SAEB - SAEBOR**
**24**

 Scanalato  
 UNI8953  
 UNI8953  
 Splined

 Coppia 330 Nm  
 Torque 245 ft-lbs

 Disponibile per - available for: **ZFC**

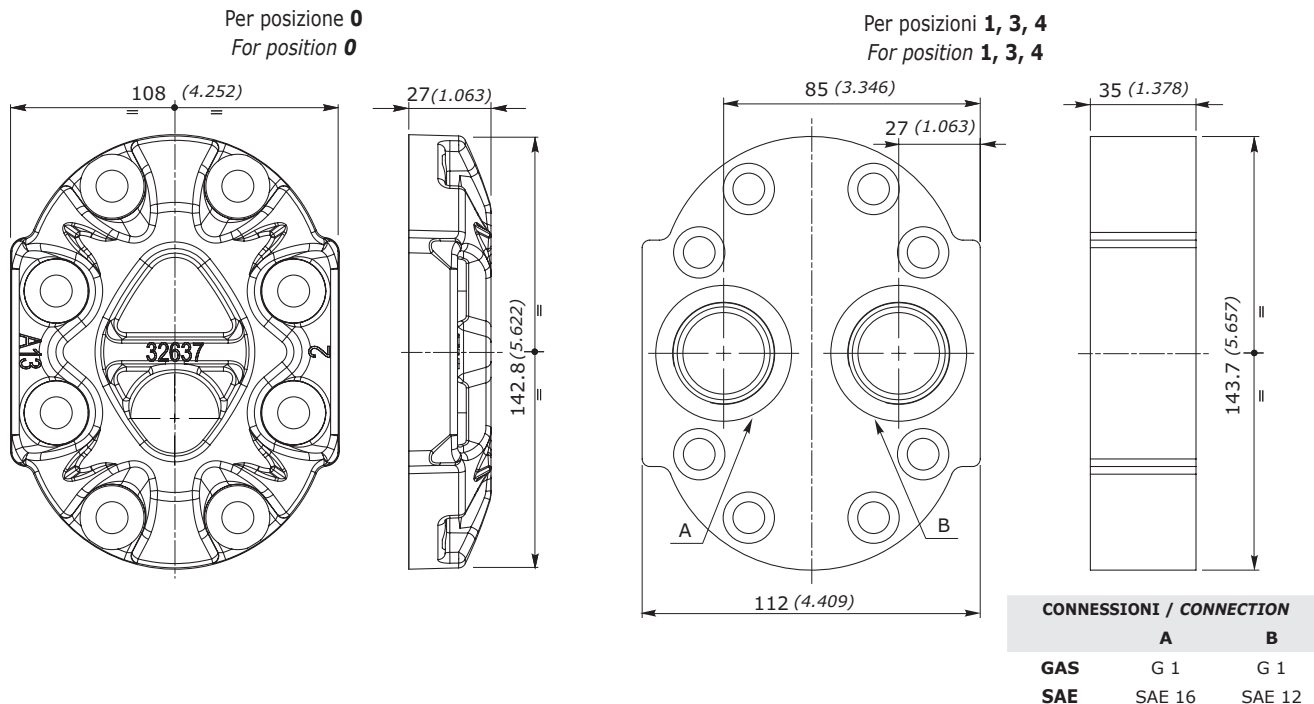
**POMPE AD INGRANAGGI GRUPPO 3GP**  
**GEAR PUMPS GROUP 3GP**

**COPERCHIO STANDARD • STANDARD COVER**

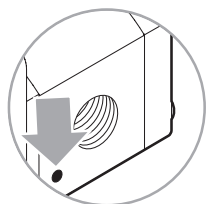
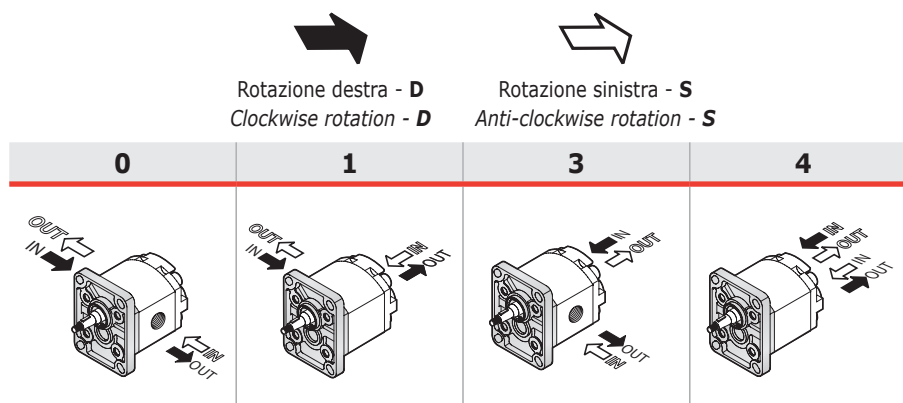

**POSIZIONE CONNESSIONE • CONNECTION POSITION**



Il segno del corpo indica il lato aspirazione per le pompe  
The sign on the body identifies the suction side for the pumps

**IN = ASPIRAZIONE - SUCTION**  
**OUT = MANDATA - DELIVERY**

**TIPO CONNESSIONE • CONNECTION TYPE**

Le connessioni rappresentate corrispondono alle versioni standard; per connessioni differenti, contattare il nostro Ufficio Commerciale. *The connection types shown correspond to standard configuration; for different applications contact our Commercial Dept.*

<b>3GP</b>		POSIZIONE CONNESSIONE - CONNECTION POSITION			
		<b>0</b>	<b>1</b>	<b>3</b>	<b>4</b>
GAS	<b>G</b>	◇	◇	◇	◇
UNF	<b>W</b>	◇	◇	◇	◇
FLANGIATE	<b>T</b>	◇			
FLANGED	<b>N</b>	◇			
	<b>F</b>	◇			

**POMPE AD INGRANAGGI GRUPPO 3GP**  
**GEAR PUMPS GROUP 3GP**
**TIPO CONNESSIONE • CONNECTION TYPE**

GAS	UNI ISO 228/1	SIGLA CODE	CIL. DISPL.	ASPIRAZIONE - SUCTION IN			MANDATA - DELIVERY OUT									
				A	B		A	B								
		<b>G</b>	190	G 1"	20 [mm] 0.788 [inch]	70 [Nm] 620 [in.lbs]	G 3/4"	17 [mm] 0.670 [inch]	60 [mm] 531 [in.lbs]							
			230													
			300													
			340													
			370													
			440													
			530													
			620													
			700													
770																
			770	G 1" 1/4	20 [mm] 0.788 [inch]	80 [Nm] 709 [in.lbs]	G 1"	20 [mm] 0.788 [inch]	70 [Nm] 620 [in.lbs]							
			UNF	ANSI/ASME B1.1	SIGLA CODE	CIL. DISPL.	ASPIRAZIONE SUCTION IN			MANDATA DELIVERY OUT						
							A	B		A	B					
					<b>W</b>	190	SAE 16 1"5/16-12 UN	20 [mm] 0.788 [inch]	70 [Nm] 620 [in.lbs]	SAE 12 1"1/16-12 UN	20 [mm] 0.788 [inch]	60 [Nm] 531 [in.lbs]				
						230										
						300										
						340										
						370										
						440										
530																
620																
700																
770																
			770	SAE 24 1"7/8-12 UN	20 [mm] 0.788 [inch]	90 [Nm] 798 [in.lbs]	SAE 20 1"5/8-12 UN	20 [mm] 0.788 [inch]	80 [Nm] 709 [in.lbs]							
			FLANGIATE FLANGED	ISO/R 262	SIGLA CODE	CIL. DISPL.	ASPIRAZIONE SUCTION IN				MANDATA DELIVERY OUT					
							A	B	C	D	A	B	C	D		
					<b>T</b>	190	26 [mm] 1.024 [inch]	55 [mm] 2.167 [inch]	M8	16 [mm] 0.630 [inch]	15 [Nm] 133 [in.lbs]	18 [mm] 0.709 [inch]	55 [mm] 2.167 [inch]	M8	16 [mm] 0.630 [inch]	15 [Nm] 133 [in.lbs]
						230										
						300										
						340										
						370										
						440										
530																
620																
700																
770																
		<b>N</b>	190	27 [mm] 1.064 [inch]	51 [mm] 2.009 [inch]	M10	15 [mm] 0.591 [inch]	20 [Nm] 177 [in.lbs]	19 [mm] 0.748 [inch]	40 [mm] 1.575 [inch]	M8	15 [mm] 0.591 [inch]	15 [Nm] 71 [in.lbs]			
			230													
			300													
			340													
			370													
			440													
			530													
			620													
			700													
			770													
FLANGIATE FLANGED	ISO/R 262	SIGLA CODE	CIL. DISPL.	ASPIRAZIONE SUCTION IN					MANDATA DELIVERY OUT							
				A	B	C	D	E		A	B	C	D	E		
		<b>F*</b>	190	26.2 [mm] 1.031 [inch]	27 [mm] 1.063 [inch]	52.4 [mm] 2.063 [inch]	M8	15 [mm] 0.591 [inch]	15 [Nm] 71 [in.lbs]		24 [mm] 0.945 [inch]	26.2 [mm] 1.031 [inch]	52.4 [mm] 2.063 [inch]	M8	15 [mm] 0.591 [inch]	15 [Nm] 71 [in.lbs]
			230													
			300													
			340													
			370													
			440													
			530													
			620													
			700													
			770													

\*: Le flange non corrispondono a norma SAEJ518. Flange a norma disponibili a richiesta, contattare il Servizio Commerciale.

\*: Flanges F do not correspond to SAEJ518. Flanges SAEJ518 available on request, please contact our Sales Dpt.

**POMPE AD INGRANAGGI GRUPPO 3GP**  
**GEAR PUMPS GROUP 3GP**

**OPZIONI • OPTIONS**

**VLPI**

VALVOLA LIMITATRICE DI PRESSIONE A SCARICO INTERNO  
PRESSURE RELIEF VALVE WITH INTERNAL EXHAUST

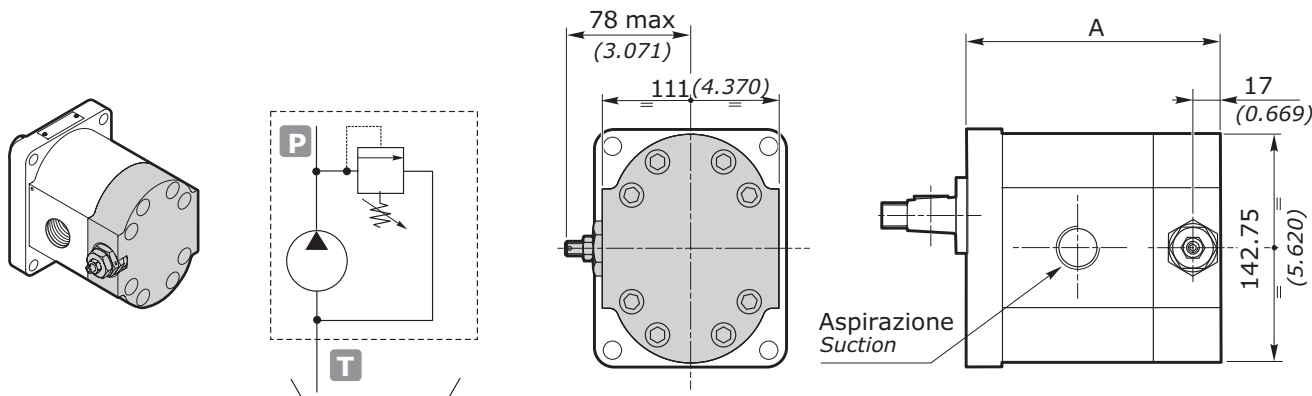

GRUPPO GROUP 3	A	
	EUR - SAEB - SAEBOR mm	inch
<b>3GP 190</b>	146.30	5.759
<b>3GP 230</b>	149.30	5.877
<b>3GP 300</b>	155.30	6.114
<b>3GP 340</b>	158.30	6.232
<b>3GP 370</b>	161.30	6.350
<b>3GP 440</b>	167.30	6.586
<b>3GP 530</b>	174.30	6.862
<b>3GP 620</b>	182.30	7.177
<b>3GP 700</b>	188.30	7.413
<b>3GP 770</b>	194.30	7.649

La valvola limitatrice di pressione si applica sostituendo il coperchio posteriore (previsto solo scarico interno). Coperchio VLP disponibile in alluminio. È rappresentata una pompa con rotazione sinistra.

**L'apertura della valvola limitatrice di pressione deve avvenire per tempi non superiori ai 7 secondi ogni minuto, per evitare il surriscaldamento della pompa.**

*The pressure relief valve can be applied by substituting the rear cover (only internal relief is set). VLP cover available in aluminum. The showed pump is with anticlockwise rotation.*

**The opening of the pressure relief valve should be carried out for times not over 7" each minute, to avoid the pump overheating of the pump.**

esempio • example: **3GP - A - 340 - D - EUR - B - N - 10 - 0 - G - VLPI (N 120)**

**VLPI** = Coperchio con VPL a scarico interno / Cover with VPL with internal exhaust

**N** = Tipo molla - vedi tabella / Spring type - see table

**120** = Taratura - vedi tabella / Setting - see table

TIPO - TYPE	CAMPI DI TARATURE - CALIBRATION FIELDS					
	molla bianca - white spring	B	molla nera - black spring	N	molla rossa - red spring	R
bar	30 ÷ 80		81 ÷ 200		201 ÷ 350	
psi	435 ÷ 1160		1175 ÷ 2900		2915 ÷ 5075	
STANDARD	70 bar (1015 psi)		150 bar (2175 psi)		250 bar (3625 psi)	

NOTA: In caso di omissione del valore di taratura, esso sarà inteso standard (vedi tabella).

NOTE: Without setting request, it will be considered standard (see table).

**POMPE AD INGRANAGGI GRUPPO 3GP**  
**GEAR PUMPS GROUP 3GP**
**VLPE**

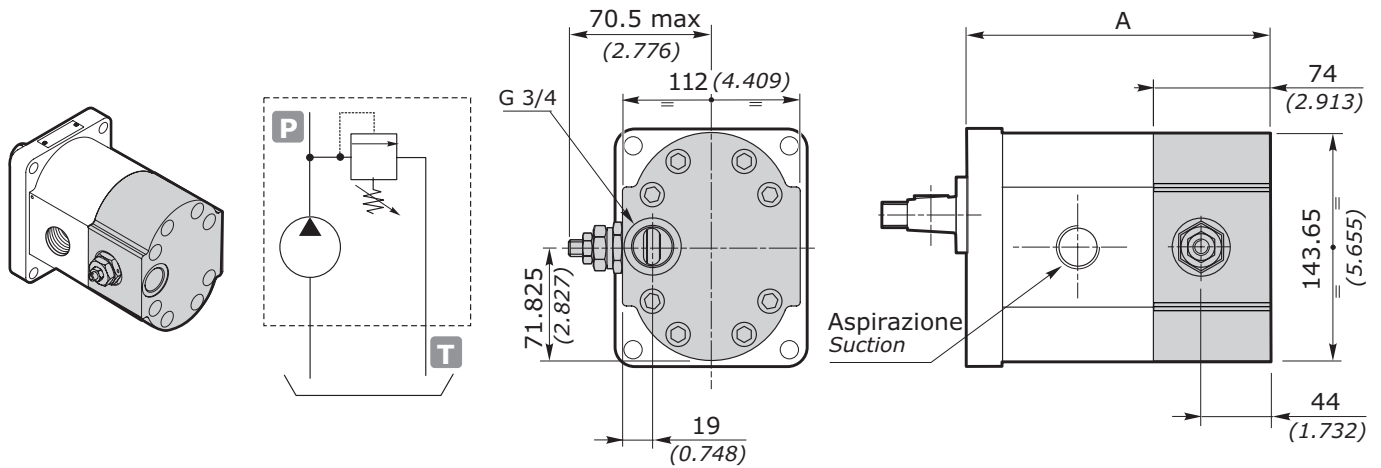
 VALVOLA LIMITATRICE DI PRESSIONE A SCARICO ESTERNO  
 PRESSURE RELIEF VALVE WITH EXTERNAL EXHAUST

GRUPPO GROUP 3	A	
	EUR - SAEB - SAEBOR mm	inch
3GP 190	176.30	6.941
3GP 230	179.30	7.059
3GP 300	185.30	7.295
3GP 340	188.30	7.413
3GP 370	191.30	7.531
3GP 440	197.30	7.767
3GP 530	204.30	8.043
3GP 620	212.30	8.358
3GP 700	218.30	8.594
3GP 770	224.30	8.830

La valvola limitatrice di pressione si applica sostituendo il coperchio posteriore. Il coperchio VLP è disponibile in alluminio. E' rappresentata una pompa con rotazione sinistra. Nelle pompe con rotazione destra, la valvola è dal lato opposto

*The pressure relief valve can be applied by substituting the rear cover. VLP cover is available in aluminum. The showed pump is with anticlockwise rotation. In the case of pumps with clockwise rotation, the valve is on the opposite side.*

 esempio • example: **3GP - A - 230 - D - EUR - B - N - 10 - 0 - G - VLPE (N 120)**
**VLPE** = Coperchio con VPL a scarico esterno / Cover with VPL with external exhaust

**N** = Tipo molla - vedi tabella / Spring type - see table

**120** = Taratura - vedi tabella / Setting - see table

TIPO - TYPE	CAMPI DI TARATURE - CALIBRATION FIELDS					
	molla bianca - white spring	B	molla nera - black spring	N	molla rossa - red spring	R
bar	30 ÷ 80		81 ÷ 200		201 ÷ 350	
psi	435 ÷ 1160		1175 ÷ 2900		2915 ÷ 5075	
STANDARD	70 bar (1015 psi)		150 bar (2175 psi)		250 bar (3625 psi)	

NOTA: In caso di omissione del valore di taratura, esso sarà inteso standard (vedi tabella).

NOTE: Without setting request, it will be considered standard (see table).



**POMPE MULTIPLE AD INGRANAGGI**  
**MULTIPLE GEAR PUMPS**

**INTRODUZIONE • INTRODUCTION**

Le pompe Galtech possono essere facilmente combinate in unità multiple con differenti cilindrate e gruppi.

Sono disponibili due tipologie di kit intermedi per combinare le pompe: STANDARD e CORTO.

L'accoppiamento STANDARD consente di flangiare una pompa standard, con albero di tipo 10, senza alcuna necessità di rimuovere la flangia anteriore. Questo kit intermedio permette inoltre di gestire aspirazioni di fluidi differenti o da serbatoi differenti, essendo gli stadi della pompa perfettamente separati grazie alla presenza dell'anello di tenuta montato sull'albero. Questa soluzione molto versatile semplifica la gestione dello stock, consentendo di assemblare una pompa multipla partendo da pompe standard, senza la necessità di gestire pompe intermedie o secondarie. E' particolarmente indicata per applicazioni del settore industriale come centrali, elettropompe, ecc. Più compatta è invece la soluzione CORTA, dove la pompa secondaria non ha flangia e monta un albero speciale di tipo 18. L'accoppiamento di tipo CORTO, in combinazione con appositi componenti, consente di realizzare pompe multiple con aspirazione comune, riducendo il numero dei tubi e favorendo una riduzione degli ingombri. Questa soluzione con ingombri longitudinali ridotti è indicata per applicazioni del settore mobile, come macchine agricole, movimento terra, ecc.

The Galtech pumps can be easily combined into multiple units with different displacements and groups.

There are two types of intermediate kits that allows to combine pumps together: STANDARD and SHORT.

The STANDARD coupling allows flange a standard pump with type shaft 10 without any need to remove the front flange.

This intermediate kit also allows to manage different fluids or fluids coming from different reservoirs, as the stages of the pump are perfectly separated between them, thanks to the presence of the seal ring mounted on the shaft.

This highly versatile solution simplifies stock management by allowing to assemble multiple pumps starting from standard pumps, without the need to manage intermediate or secondary pumps. It is particularly suitable for the industrial applications such as power plants, pumps, etc.

More compact is instead the SHORT solution, where the secondary pump has no flange, and mounting a special shaft type 18. The coupling SHORT type, in combination with appropriate components, allows to realize multiple pumps with common aspiration, reducing the number of pipes and favoring a reduction of overall dimensions.

This compact solution is suitable for the furniture industry applications, such as agricultural machinery, earthmoving, etc.

**TANDEM STANDARD (TS) • (TS) STANDARD TANDEM**

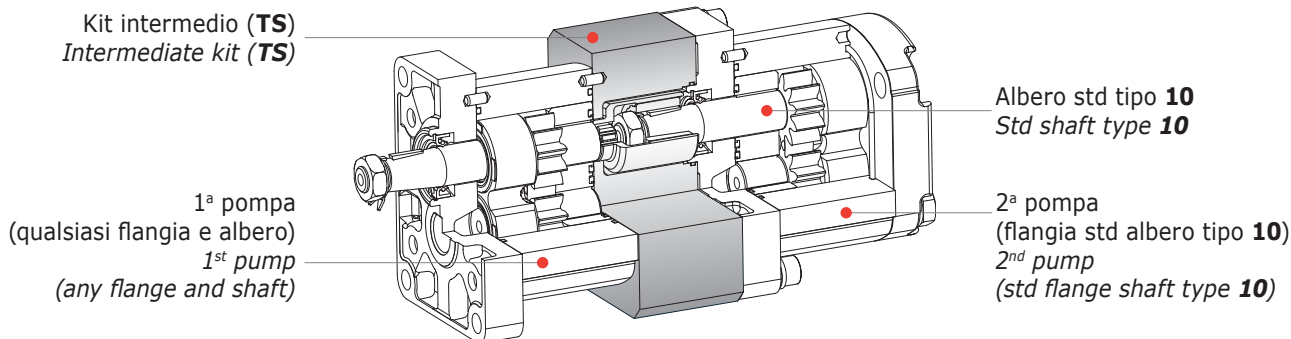

**TANDEM CORTO (TC) • (TC) SHORT TANDEM**

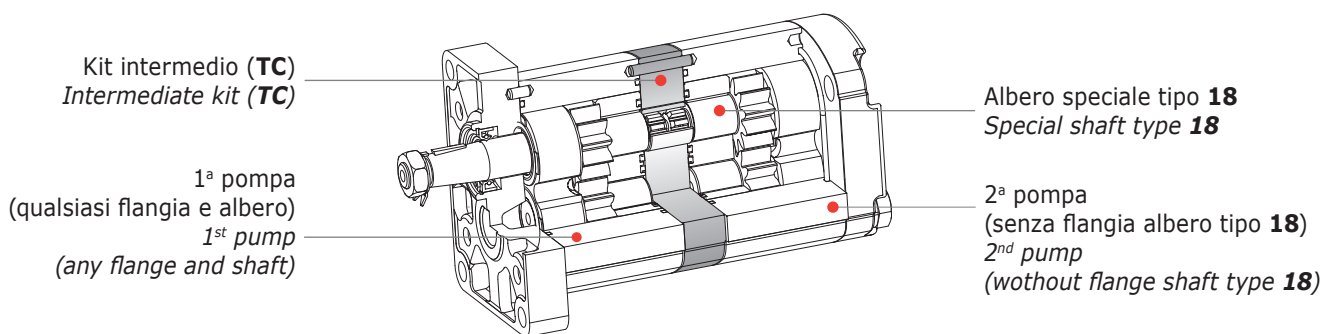

COPPIE TRASMISSIBILI DALLA GIUNZIONE - MAX. COUPLING TORQUE	TANDEM STANDARD - STANDARD TANDEM	TANDEM CORTO - SHORT TANDEM
GRUPPO - GROUP 1SP	30 [Nm] - 22 [ft.lbs]	30 [Nm] - 22 [ft.lbs]
GRUPPO - GROUP 2SP	80 [Nm] - 59 [ft.lbs]	80 [Nm] - 59 [ft.lbs]
GRUPPO - GROUP 3GP	230 [Nm] - 170 [ft.lbs]	230 [Nm] - 170 [ft.lbs]

## POMPE MULTIPLE AD INGRANAGGI **INFORMAZIONI TECNICHE** MULTIPLE GEAR PUMPS **TECHNICAL INFORMATION**

### VERIFICA COPPIE • TORQUE CALCULATION

Nella configurazione di una pompa multipla, vanno considerate le seguenti regole:

- Le varie unità vanno assemblate in ordine decrescente di potenza assorbita (di conseguenza anche coppia).
- La velocità massima di rotazione della pompa multipla è pari a quella dell'unità con velocità massima minore.
- Le pressioni di lavoro di ogni stadio coincidono con quelle della corrispondente pompa singola.
- La coppia trasmessa da ogni giunzione va verificata in modo che la somma delle coppie richieste dalle pompe successive sia inferiore al valore massimo trasmissibile dal giunto (vedi tabella).
- La somma delle coppie richieste dalle unità della pompa multipla deve risultare inferiore alla massima coppia trasmissibile dell'albero scelto.
- La potenza assorbita dalla pompa multipla è pari alla somma delle potenze assorbite dalle singole unità.

*In multiple pump definition, the following aspects should be considered:*

- *Different units must be assembled from the biggest to the smallest in terms of required power and torque*
- *Maximum rotation speed of multiple pump is equal to the unit with lowest maximum admissible speed*
- *Admissible working pressures of each stage of the multiple pump are the same of the corresponding single pump*
- *Transmissible torque must be verified for every single coupling: the sum of torque values of following stages must be lower than the maximum transmissible torque of the coupling (see table)*
- *The sum of the torques required by the multiple pump units must be lower than the maximum shaft torque capacity*
- *The power required by multiple pump is equal to the sum of the power absorbed by the individual units.*

ESEMPIO POMPA TRIPLA TRIPLE PUMP EXAMPLE	UNITÀ STAGE	PRESSIONE LAVORO WORKING PRESSURE	COPPIA TORQUE
<b>2SP 160... + 2SP 080... + 2SP 060...</b>	2SP 160	150 bar	$M1 = \frac{150 \cdot 16}{62,83 \cdot 0,9} = 42,4 \text{ Nm}$
	2SP 80	180 bar	$M2 = \frac{180 \cdot 8}{62,83 \cdot 0,9} = 25,5 \text{ Nm}$
	2SP 60	120 bar	$M3 = \frac{120 \cdot 6}{62,83 \cdot 0,9} = 12,7 \text{ Nm}$
			$M = \frac{\Delta p \cdot V}{62.83 \cdot \eta_m}$

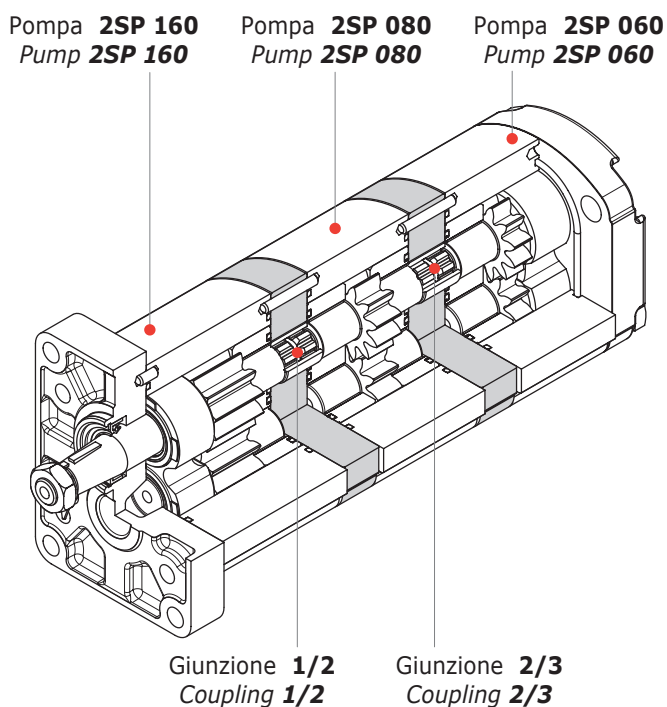

- VERIFICA GIUNZIONE 2/3 - COUPLING 2/3:

$$M3 = 12,7 \text{ Nm} < 80 \text{ Nm} \quad \checkmark$$

- VERIFICA GIUNZIONE 1/2 - COUPLING 1/2:

$$M2 + M3 = 25,5 + 12,7 \text{ Nm} = 38,2 \text{ Nm} < 80 \text{ Nm} \quad \checkmark$$

- VERIFICA ALBERO (TIPO 10) - SHAFT (TYPE 10)

$$M1 + M2 + M3 = 42,4 + 25,5 + 12,7 \text{ Nm} = 80,6 \text{ Nm} < 140 \text{ Nm} \quad \checkmark$$

- VELOCITÀ MASSIMA - MAXIMUM SPEED

$$3500 \text{ giri/min} - \text{rpm}$$

**POMPE MULTIPLE AD INGRANAGGI COMBINAZIONI**  
**MULTIPLE GEAR PUMPS COMBINATIONS**

COMBINAZIONI POMPE MULTIPLE AD INGRANAGGI MULTIPLE GEAR PUMPS COMBINATIONS		POMPA - PUMP 2			
		1SP	2SP	3GP	
<b>POMPA - PUMP 1</b>	<b>1SP</b>	Standard <i>Standard</i> <b>TS</b>	010911000000000		
		Corto <i>Short</i> <b>TC</b>	010911308680___ <sup>1</sup> 010911010000000 <sup>5</sup>		
		Corto con aspirazione unica <i>Short with common suction</i> <b>..M/..U</b>	010911010000000		
	<b>2SP</b>	Standard <i>Standard</i> <b>TS</b>	010921100000000	010922000000000	
		Corto <i>Short</i> <b>TC</b>	010921010000000	010922291890___ <sup>2</sup> 010922010000000 <sup>5</sup>	
		Corto con aspirazione unica <i>Short with common suction</i> <b>..M/..U</b>	010921010100000 <sup>4</sup>	010922010000000	
	<b>3GP</b>	Standard <i>Standard</i> <b>TS</b>	010G31000000000	010G32000000000	010G33000000000
		Corto <i>Short</i> <b>TC</b>	010G31010000000	010932100000000	010933100000000
		Corto con aspirazione unica <i>Short with common suction</i> <b>..M/..U</b>		010932102000000 <sup>3</sup> 010932101000000 <sup>4</sup>	010933102000000 <sup>3</sup> 010933101000000 <sup>4</sup>

EUR	SAEB	SAEBOR	ZFC
60	61	61	62

  

EUR	SAEA	SAEAOR	B80C	B50C	E52C	P400D	SUPEUR	SAEB
36	38	38	40	41	42	43	44	45

EUR	SAEAA	MC32	E32BX	E32BC	E32CX	E32CC
20	21	22	23	24	25	26

(1) = vedi tabella 1.a pagina 82 / see table 1.a page 82  
 (2) = vedi tabella 2.a pagina 82 / see table 2.a page 82  
 (3) = rotazione sinistra / anticlockwise rotation  
 (4) = rotazione destra / clockwise rotation  
 (5) = senza kit tiranti / without tie rods kit

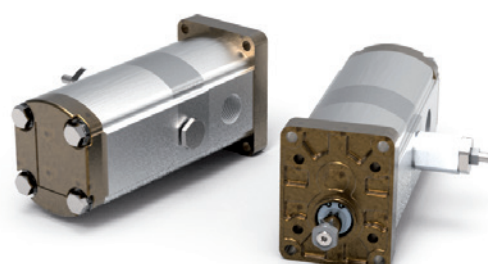

## POMPE MULTIPLE AD INGRANAGGI **COMBINAZIONI** MULTIPLE GEAR PUMPS **COMBINATIONS**

### 1.a

ELENCO CODICI KIT FLANGIA INTERMEDIA E TIRANTE **1SP - 1SP** (TANDEM CORTO)  
PART LIST INTERMEDIATE FLANGE AND TIE ROD KIT **1SP - 1SP** (SHORT TANDEM)

1SP	009	012	016	020	025	032	037	042	050	063	078	098
009	100											
012	100	100										
016	100	100	100									
020	100	100	100	100								
025	100	100	100	100	100							
032	100	100	100	100	200	200						
037	100	100	200	200	200	200	200					
042	100	200	200	200	200	200	200	300				
050	200	200	200	200	200	200	300	300	300			
063	200	200	200	200	300	300	300	300	300	400		
078	300	300	300	300	300	300	400	400	400	400	500	
098	300	300	300	400	400	400	400	400	500	500	600	600

Esempio codice di ordinazione /  
 Order code example: 010911308680**100**  
 010911308680 = codice fisso - fixed code  
**100** = vedi tabella 1.a - see table 1.a

### 2.a

ELENCO CODICI KIT FLANGIA INTERMEDIA E TIRANTE **2SP - 2SP** (TANDEM CORTO)  
PART LIST INTERMEDIATE FLANGE AND TIE ROD KIT **2SP - 2SP** (SHORT TANDEM)

2SP	040	060	080	110	140	160	190	220	260	310
040	100									
060	100	100								
080	100	100	200							
110	100	200	200	200						
140	200	200	200	300	300					
160	200	200	300	300	300	400				
190	200	300	300	300	400	400	500			
220	300	300	300	400	400	500	500	500		
260	300	400	400	400	500	500	500	600	600	
310	400	400	500	500	500	600	600			

Esempio codice di ordinazione /  
 Order code example: 010922291890**100**  
 010922291890 = codice fisso - fixed code  
**100** = vedi tabella 2.a - see table 2.a

### DESCRIZIONE TANDEM CORTO ASPIRAZIONE UNICA • TANDEM SHORT WITH COMMON SUCTION DESCRIPTION

esempio • example: **1SP - A - 009 - D - EUR - B - N - 10 - OU - G / TC / 1SP - A - 009 - OM - G**

**OU** = Aspirazione unica e mandata in posizione 0

*Common suction and delivery on position 0*

**OM** = Mandata in posizione 0 / Delivery on position 0

esempio • example: **1SP - A - 009 - D - EUR - B - N - 10 - OM - G / TC / 1SP - A - 009 - 4U - G**

**OM** = Mandata in posizione 0 / Delivery on position 0

**4U** = Aspirazione unica in posizione 4 / Common suction on position 4

esempio • example: **1SP - A - 009 - D - EUR - B - N - 10 - OM - G / TC / 1SP - A - 009 - OU - G / TC / 1SP - A - 009 - OM**

**OM** = Mandata in posizione 0 / Delivery on position 0

**4U** = Aspirazione unica in posizione 4 / Common suction on position 4

**OM** = Mandata in posizione 0 / Delivery on position 0

**POMPE MULTIPLE AD INGRANAGGI**  
**MULTIPLE GEAR PUMPS**

**CODICE ORDINAZIONE • ORDER CODE**

**POMPA DOPPIA • DOUBLE PUMP**  
**1SP + 1SP**

PRIMA POMPA  
FIRST PUMP

SECONDA POMPA  
SECOND PUMP

**1SP - A - 020 - D - EUR - B - N - 10 - 0 - G / TS / 1SP - A - 020 - 0 - G**

KIT INTERMEDIO  
INTERMEDIATE KIT

SIGLA - CODE	TIPO - TYPE	DESCRIZIONE - DESCRIPTION	PAGINA - PAGE	
PRIMA POMPA - FIRST PUMP	<b>1SP</b>	Tipo pompa <i>Pump type</i>	Pompa singola - gruppo 1 <i>Single pump - group 1</i>	4
	<b>A</b>	Materiale flangia e coperchio <i>Flange and cover material</i>	<b>A</b> = alluminio / <i>aluminium</i>	
	<b>020</b>	Cilindrata <i>Displacement</i>	Cilindrata = 2 cm <sup>3</sup> /giro <i>Displacement = 0.12 in<sup>3</sup>/rev</i>	4
	<b>D</b>	Senso di rotazione <i>Rotation wise</i>	<b>D</b> = Rotazione destra / <i>Clockwise rotation</i> <b>S</b> = Rotazione sinistra / <i>Anticlockwise rotation</i> <b>R</b> = Reversibile / <i>Reversible</i>	8
	<b>EUR</b>	Tipo Flangia <i>Flange type</i>	Flangia europea standard <i>Standard European flange</i>	26
	<b>B</b>	Tipo anello di tenuta <i>Seal ring type</i>	Vedi tabella compatibilità <i>See compatibility table</i>	
	<b>N</b>	Tipo guarnizione <i>Gasket type</i>	<b>N</b> = NBR <b>V</b> = Viton	27
	<b>10</b>	Tipo Albero <i>Shaft type</i>	Vedi tabella compatibilità <i>See compatibility table</i>	28
	<b>0</b>	Posizione connessione <i>Connection position</i>	Vedi tabella compatibilità <i>See compatibility table</i>	30
	<b>G</b>	Tipo connessione <i>Connection type</i>	Vedi tabella compatibilità <i>See compatibility table</i>	
<b>TS</b>	Tipo TANDEM <i>TANDEM type</i>	<b>TS</b> = Tandem Standard / <i>Standard tandem</i> <b>TC</b> = Tandem Corto / <i>Short tandem</i> <b>..M/..U</b> * = Tandem Corto con aspirazione unica / <i>Tandem short with common suction</i>		
SECONDA POMPA - SECOND PUMP	<b>1SP</b>	Tipo pompa <i>Pump type</i>	Pompa singola - gruppo 1 <i>Single pump - group 1</i>	4
	<b>A</b>	Materiale flangia e coperchio <i>Flange and cover material</i>	<b>A</b> = alluminio / <i>aluminium</i>	
	<b>020</b>	Cilindrata <i>Displacement</i>	Cilindrata = 2 cm <sup>3</sup> /giro <i>Displacement = 0.12 in<sup>3</sup>/rev</i>	4
	<b>0</b>	Posizione connessione <i>Connection position</i>	Vedi tabella compatibilità <i>See compatibility table</i>	30
	<b>G</b>	Tipo connessione <i>Connection type</i>	Vedi tabella compatibilità <i>See compatibility table</i>	

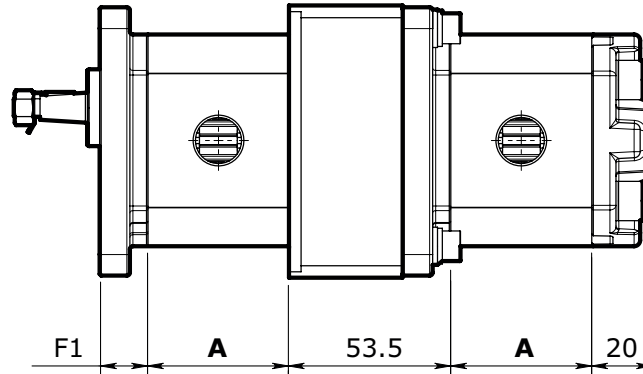
**POMPE MULTIPLE AD INGRANAGGI  
MULTIPLE GEAR PUMPS**
**DIMENSIONI • DIMENSIONS**
**TANDEM STANDARD TS • TS STANDARD TANDEM**

**TANDEM CORTO TC • TC SHORT TANDEM**

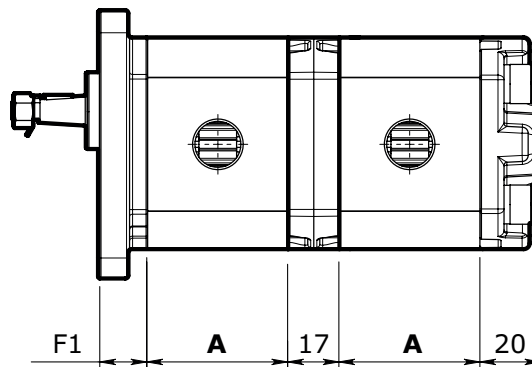
Le dimensioni sono le stesse per tandem corto con aspirazione unica **..M/..U**. *Dimensions are the same for tandem short with common suction **..M/..U**.*



<b>1SP</b>		CILINDRATA - DISPLACEMENT											
		<b>009</b>	<b>012</b>	<b>016</b>	<b>020</b>	<b>025</b>	<b>032</b>	<b>037</b>	<b>042</b>	<b>050</b>	<b>063</b>	<b>078</b>	<b>098</b>
<b>A</b>	mm	37.6	38.7	40.4	41.9	43.9	46.6	48.6	50.0	53.6	58.7	64.4	72.3
	in	1.48	1.52	1.59	1.65	1.73	1.83	1.91	1.99	2.11	2.31	2.54	2.85

<b>1SP</b>		FLANGIA - FLANGE						
		<b>EUR</b>	<b>SAEAA</b>	<b>MC32</b>	<b>E32BX</b>	<b>E32BC</b>	<b>E32CX</b>	<b>E32CC</b>
<b>F1</b>	mm	16	19,5	16	16	16	16	
	in	0,63	0,77	0,63	0,63	0,63	0,63	

(\*) - Per descrizione tandem corto con aspirazione unica vedere pag. 82. Contattare il Servizio Commerciale per combinazioni e flange disponibili.

(\*) - For Tandem short with common suction see page 82. Please contact our Sales Dpt for available combinations and flanges.

**POMPE MULTIPLE AD INGRANAGGI  
MULTIPLE GEAR PUMPS**

**VD**

**POMPA CON VALVOLA DISGIUNTRICE 1SP + 1SP  
HIGH LOW PUMPS 1SP + 1SP**

La pompa con valvola disgiuntrice è una pompa in tandem a due stadi con una valvola di sequenza posta nella flangia intermedia. Quando la pompa lavora a bassa pressione la portata delle due pompe si somma per un avvicinamento o allontanamento rapido. Quando la pressione supera il valore di taratura della valvola di sequenza, questa mette a scarico la seconda pompa. La versatilità delle nostre pompe consente il montaggio di una pompa con valvola disgiuntrice utilizzando pompe singole ed effettuando solo operazioni di disassemblaggio/assemblaggio di estrema semplicità.

*The high low pump is a two-stages tandem pump with a sequence valve on the intermediate flange.*

*When the pumps work at low pressure, the flows of the two pumps add up, allowing a rapid approaching or moving away of the actuator.*

*When the pressure exceeds the setting value of the sequence valve, the second pump's exhaust goes to the tank.*

*The versatility of our pumps allows the assembling of a high low pump by using single pumps and only by carrying out very simple assembling/disassembling processes.*

**CARATTERISTICHE TECNICHE • TECHNICAL FEATURES**

- Le prestazioni delle unità che compongono la pompa multipla sono identiche a quelle delle singole pompe precedenti.
- Questa pompa ha l'aspirazione unica e la mandata unica, l'aspirazione deve sempre essere nel secondo stadio e la mandata nel primo.
- Può essere dotata di tutte le tipologie di flange presenti nella nostra gamma, di alberi e le relative connessioni.
- La valvola disgiuntrice è registrabile da 20 a 100 bar.

- *The performances of the units which make the multiple pump are the same as the previous single pumps.*
- *This pump has common suction and delivery: the suction always has to be at the second stage, while delivery always has to be at the first stage.*
- *It can be supplied with every kind of flanges, shafts and corresponding connections available in our range.*
- *The high low pump can be set at 20 bar up to 100 bar.*

CILINDRATA 1° STADIO DISPLACEMENT 1 <sup>ST</sup> STAGE		CILINDRATA 2° STADIO DISPLACEMENT 2 <sup>ND</sup> STAGE		DIMENSIONI - DIMENSIONS								MASSA MASS	
cm <sup>3</sup> /giro	in <sup>3</sup> /rev	cm <sup>3</sup> /giro	in <sup>3</sup> /rev	A		B		C		D		Kg	lbs
				mm	inch	mm	inch	mm	inch	mm	inch		
0.9	0.05	3.7	0.23	154.2	6.071	142.2	5.598	109.9	4.327	34.8	1.370	1.89	4.17
		4.2	0.26	156.1	6.146	144.1	5.673	110.9	4.364			1.91	4.21
		5.0	0.31	159.2	6.268	147.2	5.795	112.4	4.425			1.96	4.32
		6.3	0.38	164.3	6.469	152.3	5.996	115.0	4.526			2.04	4.50
		7.8	0.47	160.0	6.299	148.0	5.827	112.8	4.441			2.13	4.70
		9.8	0.60	177.9	7.004	165.9	6.531	121.8	4.793			2.23	4.92
1.2	0.07	3.7	0.23	155.3	6.114	143.3	5.642	111.0	4.370	35.1	1.382	1.91	4.21
		4.2	0.26	157.2	6.189	145.2	5.717	112.0	4.407			1.92	4.23
		5.0	0.31	160.3	6.311	148.3	5.839	113.5	4.469			1.98	4.37
		6.3	0.38	165.4	6.512	153.4	6.039	116.1	4.569			2.05	4.52
		7.8	0.47	161.1	6.343	149.1	5.870	113.9	4.484			2.14	4.72
		9.8	0.60	179.0	7.047	167.0	6.575	122.9	4.837			2.25	4.96
1.6	0.10	3.7	0.23	157.0	6.181	145.0	5.709	112.7	4.437	36.2	1.425	1.93	4.26
		4.2	0.26	158.9	6.256	146.9	5.783	113.7	4.474			1.95	4.30
		5.0	0.31	162.0	6.378	150.0	5.906	115.2	4.535			2.00	4.41
		6.3	0.38	167.1	6.579	155.1	6.106	117.8	4.636			2.07	4.56
		7.8	0.47	162.8	6.409	150.8	5.937	115.6	4.551			2.17	4.78
		9.8	0.60	180.7	7.114	168.7	6.642	124.6	4.904			2.27	5.01
2.0	0.12	3.7	0.23	158.5	6.240	146.5	5.768	114.2	4.496	37.0	1.457	1.95	4.30
		4.2	0.26	160.4	6.315	148.4	5.843	115.2	4.533			1.97	4.34
		5.0	0.31	163.5	6.437	151.5	5.965	116.7	4.594			2.02	4.45
		6.3	0.38	168.6	6.638	156.6	6.165	119.3	4.695			2.09	4.61
		7.8	0.47	164.3	6.469	152.3	5.996	117.1	4.610			2.19	4.83
		9.8	0.60	182.2	7.173	170.2	6.701	126.1	4.963			2.29	5.05
2.5	0.15	3.7	0.23	160.5	6.319	148.5	5.846	116.2	4.575	38.0	1.496	1.98	4.37
		4.2	0.26	162.4	6.394	150.4	5.921	117.2	4.612			1.99	4.39
		5.0	0.31	165.5	6.516	153.5	6.043	118.7	4.673			2.04	4.50
		6.3	0.38	170.6	6.717	158.6	6.244	121.3	4.774			2.12	4.67
		7.8	0.47	166.3	6.547	154.3	6.075	119.1	4.689			2.21	4.87
		9.8	0.60	184.2	7.252	172.2	6.780	128.1	5.041			2.32	5.12
3.2	0.20	3.7	0.23	163.2	6.425	151.2	5.953	118.9	4.681	39.3	1.547	2.01	4.43
		4.2	0.26	165.1	6.500	153.1	6.028	119.9	4.719			2.03	4.48
		5.0	0.31	168.2	6.622	156.2	6.150	121.4	4.780			2.08	4.59
		6.3	0.38	173.3	6.823	161.3	6.350	124.0	4.880			2.15	4.74
		7.8	0.47	169.0	6.654	157.0	6.181	121.8	4.795			2.25	4.96
		9.8	0.60	186.9	7.358	174.9	6.886	130.8	5.148			2.35	5.18

Nota - Per accoppiamenti di cilindrato differenti e relative dimensioni contattare il servizio commerciale.

*Note - For different couplings of displacements and related dimensions please contact our Sales Dpt.*

## POMPE MULTIPLE AD INGRANAGGI MULTIPLE GEAR PUMPS

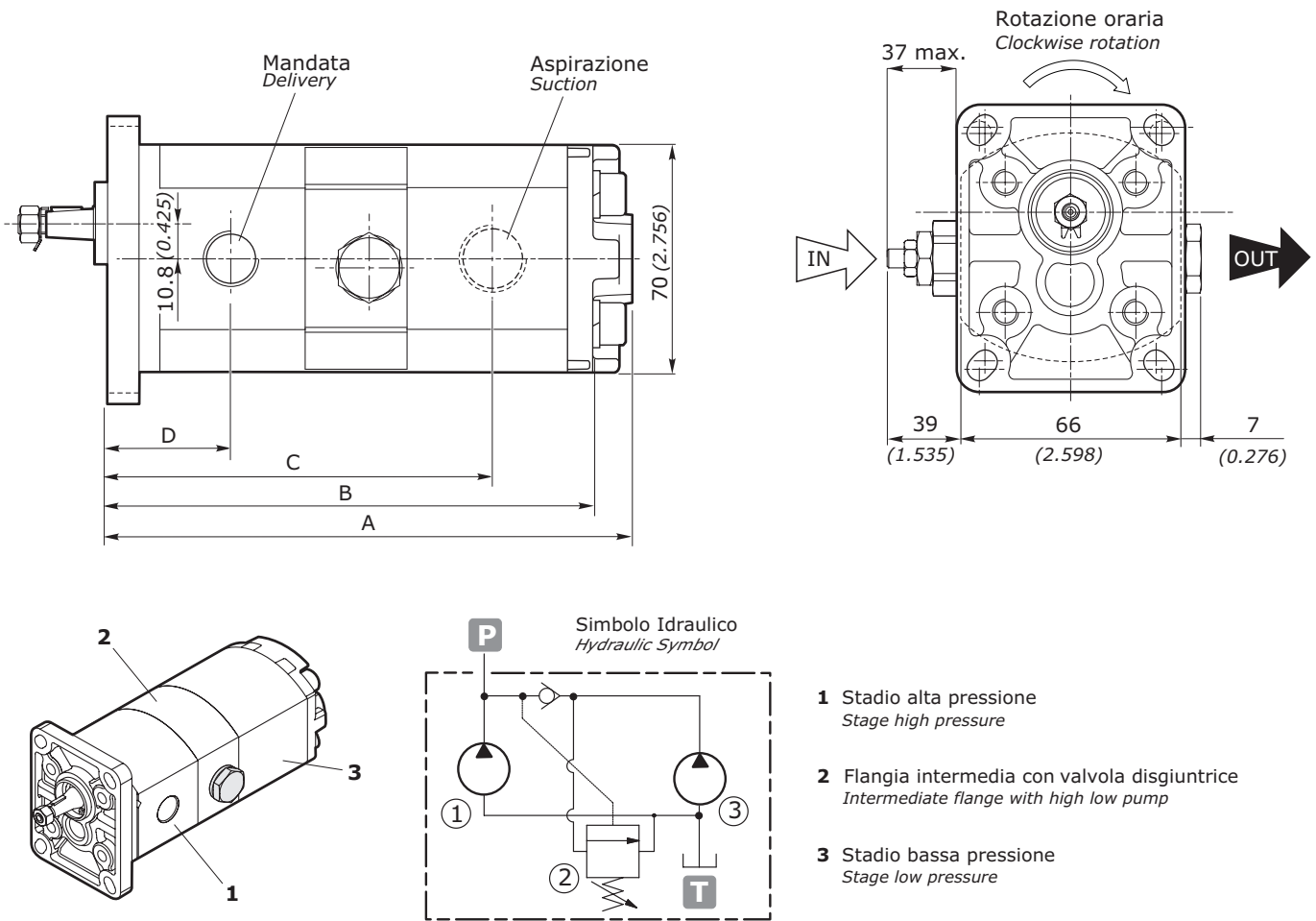

esempio • example: **1SP - A - 020 - D - EUR - B - N - 10 - 0 - G / VD 100 / 1SP - A - 050 - 0 - G**

**VD** = Valvola disgiuntrice / High low pump

**100** = Campo di Taratura 20÷100 (bar) / Setting range 20÷100 (bar)



**POMPE MULTIPLE AD INGRANAGGI**  
**MULTIPLE GEAR PUMPS**
**CODICE ORDINAZIONE • ORDER CODE**
**POMPA DOPPIA • DOUBLE PUMP**  
**2SP + 1SP**

 PRIMA POMPA  
 FIRST PUMP

 SECONDA POMPA  
 SECOND PUMP

**2SP - A - 140 - D - EUR - B - N - 10 - 0 - G / TS / 1SP - A - 020 - 0 - G**

 KIT INTERMEDIO  
 INTERMEDIATE KIT

SIGLA - CODE	TIPO - TYPE	DESCRIZIONE - DESCRIPTION	PAGINA - PAGE	
PRIMA POMPA - FIRST PUMP	<b>2SP</b>	Tipo pompa <i>Pump type</i>	Pompa singola - gruppo 2 <i>Single pump - group 2</i>	5
	<b>A</b>	Materiale flangia e coperchio <i>Flange and cover material</i>	<b>A</b> = alluminio / <i>aluminium</i>	
	<b>140</b>	Cilindrata <i>Displacement</i>	Cilindrata = 12 cm <sup>3</sup> /giro <i>Displacement = 0.85 in<sup>3</sup>/rev</i>	5
	<b>D</b>	Senso di rotazione <i>Rotation wise</i>	<b>D</b> = Rotazione destra / <i>Clockwise rotation</i> <b>S</b> = Rotazione sinistra / <i>Anticlockwise rotation</i> <b>R</b> = Reversibile / <i>Reversible</i>	8
	<b>EUR</b>	Tipo Flangia <i>Flange type</i>	Flangia europea standard <i>Standard european flange</i>	50
	<b>B</b>	Tipo anello di tenuta <i>Seal ring type</i>	Vedi tabella compatibilità <i>See compatibility table</i>	51
	<b>N</b>	Tipo guarnizione <i>Gasket type</i>	<b>N</b> = NBR <b>V</b> = Viton	50
	<b>10</b>	Tipo Albero <i>Shaft type</i>	Vedi tabella compatibilità <i>See compatibility table</i>	52
	<b>0</b>	Posizione connessione <i>Connection position</i>	Vedi tabella compatibilità <i>See compatibility table</i>	57
	<b>G</b>	Tipo connessione <i>Connection type</i>	Vedi tabella compatibilità <i>See compatibility table</i>	58
<b>TS</b>	Tipo TANDEM <i>TANDEM type</i>	<b>TS</b> = Tandem Standard / <i>Standard tandem</i> <b>TC</b> = Tandem Corto / <i>Short tandem</i> <b>..M/..U*</b> = Tandem Corto con aspirazione unica / <i>Tandem short with common suction</i>		
SECONDA POMPA - SECOND PUMP	<b>1SP</b>	Tipo pompa <i>Pump type</i>	Pompa singola - gruppo 1 <i>Single pump - group 1</i>	4
	<b>A</b>	Materiale flangia e coperchio <i>Flange and cover material</i>	<b>A</b> = alluminio / <i>aluminium</i>	
	<b>020</b>	Cilindrata <i>Displacement</i>	Cilindrata = 2 cm <sup>3</sup> /giro <i>Displacement = 0.12 in<sup>3</sup>/rev</i>	4
	<b>0</b>	Posizione connessione <i>Connection position</i>	Vedi tabella compatibilità <i>See compatibility table</i>	29
	<b>G</b>	Tipo connessione <i>Connection type</i>	Vedi tabella compatibilità <i>See compatibility table</i>	30

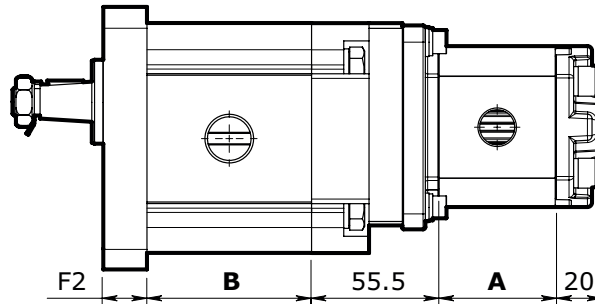
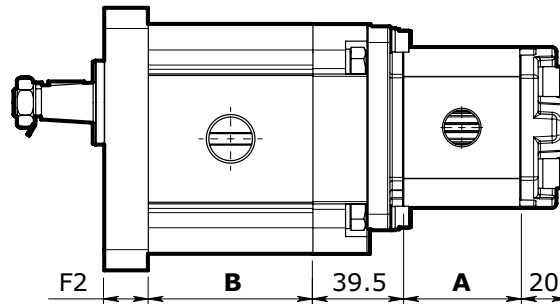
**POMPE MULTIPLE AD INGRANAGGI  
MULTIPLE GEAR PUMPS**
**DIMENSIONI • DIMENSIONS**
**TANDEM STANDARD TS • TS STANDARD TANDEM**

**TANDEM CORTO TC • TC SHORT TANDEM**

<b>1SP</b>		CILINDRATA - DISPLACEMENT											
		<b>009</b>	<b>012</b>	<b>016</b>	<b>020</b>	<b>025</b>	<b>032</b>	<b>037</b>	<b>042</b>	<b>050</b>	<b>063</b>	<b>078</b>	<b>098</b>
<b>A</b>	mm	37.6	38.7	40.4	41.9	43.9	46.6	48.6	50.0	53.6	58.7	64.4	72.3
	in	1.48	1.52	1.59	1.65	1.73	1.83	1.91	1.99	2.11	2.31	2.54	2.85

<b>2SP</b>		CILINDRATA - DISPLACEMENT									
		<b>040</b>	<b>060</b>	<b>080</b>	<b>110</b>	<b>140</b>	<b>160</b>	<b>190</b>	<b>220</b>	<b>260</b>	<b>310</b>
<b>B</b>	mm	50.8	54.1	58.3	62.4	67.4	71.6	76.6	81.6	87.4	95.8
	in	2.00	2.13	2.30	2.46	2.65	2.82	3.02	3.21	3.44	3.77

<b>2SP</b>		FLANGIA - FLANGE						
		<b>EUR</b>	<b>SAEA</b>	<b>B80C</b>	<b>B50C</b>	<b>E32C</b>	<b>M52C</b>	<b>P400D</b>
<b>F2</b>	mm	19	19	21	19	16.3	16.3	19
	in	0.75	0.75	0.83	0.75	0.64	0.64	0.75

**TANDEM CORTO CON ASPIRAZIONE UNICA ..M/..U • ..M/..U SHORT TANDEM WITH COMMON SUCTION**

Le dimensioni non indicate sono le stesse del tandem corto TC.

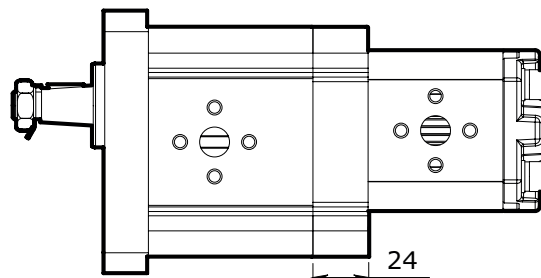

Dimensions not indicated are the same as short tandem TC.

(\*) - Per descrizione tandem corto con aspirazione unica vedere pag. 82. Contattare il Servizio Commerciale per combinazioni e flange disponibili.

(\*) - For Tandem short with common suction see page 82. Please contact our Sales Dpt for available combinations and flanges.

**POMPE MULTIPLE AD INGRANAGGI  
MULTIPLE GEAR PUMPS**

**CODICE ORDINAZIONE • ORDER CODE**

**POMPA DOPPIA • DOUBLE PUMP  
2SP + 2SP**

PRIMA POMPA  
FIRST PUMP

SECONDA POMPA  
SECOND PUMP

**2SP - A - 140 - D - EUR - B - N - 10 - 0 - G / TS / 2SP - A - 140 - 0 - G**

KIT INTERMEDIO  
INTERMEDIATE KIT

SIGLA - CODE	TIPO - TYPE	DESCRIZIONE - DESCRIPTION	PAGINA - PAGE	
PRIMA POMPA - FIRST PUMP	<b>2SP</b>	Tipo pompa <i>Pump type</i>	Pompa singola - gruppo 2 <i>Single pump - group 2</i>	5
	<b>A</b>	Materiale flangia e coperchio <i>Flange and cover material</i>	<b>A</b> = alluminio / <i>aluminium</i>	
	<b>140</b>	Cilindrata <i>Displacement</i>	Cilindrata = 14 cm <sup>3</sup> /giro <i>Displacement = 0.85 in<sup>3</sup>/rev</i>	5
	<b>D</b>	Senso di rotazione <i>Rotation wise</i>	<b>D</b> = Rotazione destra / <i>Clockwise rotation</i> <b>S</b> = Rotazione sinistra / <i>Anticlockwise rotation</i> <b>R</b> = Reversibile / <i>Reversible</i>	8
	<b>EUR</b>	Tipo Flangia <i>Flange type</i>	Flangia europea standard <i>Standard european flange</i>	50
	<b>B</b>	Tipo anello di tenuta <i>Seal ring type</i>	Vedi tabella compatibilità <i>See compatibility table</i>	51
	<b>N</b>	Tipo guarnizione <i>Gasket type</i>	<b>N</b> = NBR <b>V</b> = Viton	50
	<b>10</b>	Tipo Albero <i>Shaft type</i>	Vedi tabella compatibilità <i>See compatibility table</i>	52
	<b>0</b>	Posizione connessione <i>Connection position</i>	Vedi tabella compatibilità <i>See compatibility table</i>	57
	<b>G</b>	Tipo connessione <i>Connection type</i>	Vedi tabella compatibilità <i>See compatibility table</i>	58
<b>TS</b>	Tipo TANDEM <i>TANDEM type</i>	<b>TS</b> = Tandem Standard / <i>Standard tandem</i> <b>TC</b> = Tandem Corto / <i>Short tandem</i> <b>..M/..U*</b> = Tandem Corto con aspirazione unica / <i>Tandem short with common suction</i>		
SECONDA POMPA - SECOND PUMP	<b>2SP</b>	Tipo pompa <i>Pump type</i>	Pompa singola - gruppo 2 <i>Single pump - group 2</i>	5
	<b>A</b>	Materiale flangia e coperchio <i>Flange and cover material</i>	<b>A</b> = alluminio / <i>aluminium</i>	
	<b>140</b>	Cilindrata <i>Displacement</i>	Cilindrata = 14 cm <sup>3</sup> /giro <i>Displacement = 0.85 in<sup>3</sup>/rev</i>	5
	<b>0</b>	Posizione connessione <i>Connection position</i>	Vedi tabella compatibilità <i>See compatibility table</i>	57
	<b>G</b>	Tipo connessione <i>Connection type</i>	Vedi tabella compatibilità <i>See compatibility table</i>	58

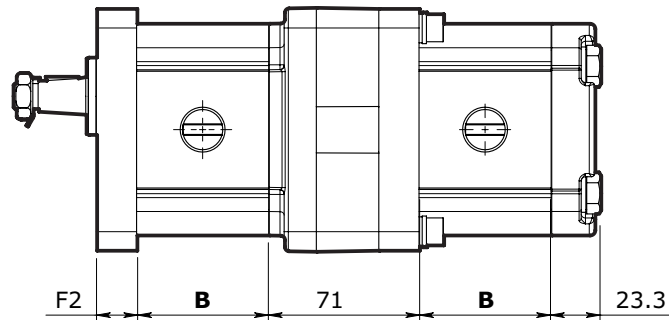
**POMPE MULTIPLE AD INGRANAGGI  
MULTIPLE GEAR PUMPS**
**DIMENSIONI • DIMENSIONS**
**TANDEM STANDARD TS • TS STANDARD TANDEM**

**TANDEM CORTO TC • TC SHORT TANDEM**

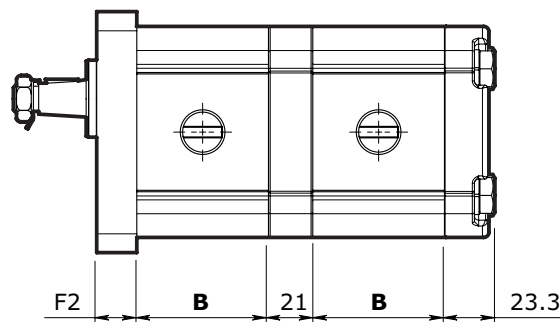
Le dimensioni sono le stesse per tandem corto con aspirazione unica **..M/..U**.  
 Dimensions are the same for tandem short with common suction **..M/..U**.



<b>2SP</b>		CILINDRATA - DISPLACEMENT									
		<b>040</b>	<b>060</b>	<b>080</b>	<b>110</b>	<b>140</b>	<b>160</b>	<b>190</b>	<b>220</b>	<b>260</b>	<b>310</b>
<b>B</b>	mm	50.8	54.1	58.3	62.4	67.4	71.6	76.6	81.6	87.4	95.8
	in	2.00	2.13	2.30	2.46	2.65	2.82	3.02	3.21	3.44	3.77

<b>2SP</b>		FLANGIA - FLANGE					
		<b>EUR</b>	<b>SAEA</b>	<b>B80C</b>	<b>B50C</b>	<b>E32C</b>	<b>P400D</b>
<b>F2</b>	mm	19	19	21	19	16.3	19
	in	0.75	0.75	0.83	0.75	0.64	0.75

(\*) - Per descrizione tandem corto con aspirazione unica vedere pag. 82. Contattare il Servizio Commerciale per combinazioni e flange disponibili.

(\*) - For Tandem short with common suction see page 82. Please contact our Sales Dpt for available combinations and flanges.

**POMPE MULTIPLE AD INGRANAGGI**  
**MULTIPLE GEAR PUMPS**

**VD**

POMPA CON VALVOLA DISGIUNTRICE **2SP + 2SP**  
HIGH LOW PUMPS **2SP + 2SP**

La pompa con valvola disgiuntrice è una pompa in tandem a due stadi con una valvola di sequenza posta nella flangia intermedia. Quando la pompa lavora a bassa pressione la portata delle due pompe si somma per un avvicinamento o allontanamento rapido. Quando la pressione supera il valore di taratura della valvola di sequenza, questa mette a scarico la seconda pompa. La versatilità delle nostre pompe consente il montaggio di una pompa con valvola disgiuntrice utilizzando pompe singole ed effettuando solo operazioni di disassemblaggio/assemblaggio di estrema semplicità.

*The high low pump is a two-stage tandem pump having a sequence valve on the intermediate flange.*

*When the pumps works at low pressure, the flows of the two pumps add up, allowing a rapid approaching or moving away of the actuator.*

*When the pressure exceeds the setting value of the sequence valve, the second pump's exhaust goes to the tank. The versatility of our pumps allows the assembling of a high low pump by using single pumps and only by carrying out very simple assembling/disassembling processes.*

**CARATTERISTICHE TECNICHE • TECHNICAL FEATURES**

- Le prestazioni delle unità che compongono la pompa multipla sono identiche a quelle delle singole pompe precedenti.
- Questa pompa ha l'aspirazione unica e la mandata unica, l'aspirazione deve sempre essere nel secondo stadio e la mandata nel primo. Può essere dotata di tutte le tipologie di flange presenti nella nostra gamma, di alberi e le relative connessioni (tranne gli attacchi N, M e F).
- La valvola disgiuntrice è registrabile da 25 a 100 bar.
- *The performances of the units of the multiple pump are the same as the previous.*
- *This pump has common suction and delivery: the suction has always to be at the second stage, while delivery has always to be at the first stage. It can be supplied with every kind of flanges, shafts and corresponding connections except for the connections type N, M and F.*
- *The high low pump can be set from 25 bar up to 100 bar.*

CILINDRATA 1° STADIO DISPLACEMENT 1 <sup>ST</sup> STAGE		CILINDRATA 2° STADIO DISPLACEMENT 2 <sup>ND</sup> STAGE		DIMENSIONI - DIMENSIONS								MASSA MASS	
cm <sup>3</sup> /giro	in <sup>3</sup> /rev	cm <sup>3</sup> /giro	in <sup>3</sup> /rev	A		B		C		D		Kg	lbs
				mm	inch	mm	inch	mm	inch	mm	inch		
4	0.22	16	0.88	204.7	8.06	195.6	7.70	145.6	5.73	44.4	1.75	5.22	11.52
		19	1.05	209.7	8.26	200.6	7.90	148.1	5.83			5.34	11.78
		22	1.21	214.7	8.45	205.6	8.09	150.6	5.93			5.47	12.07
		26	1.43	220.5	8.68	211.4	8.32	153.5	6.04			5.61	12.38
		31	1.71	223.8	8.81	214.7	8.45	155.2	6.12			5.77	12.73
6	0.33	16	0.88	208.0	8.19	198.9	7.83	148.9	5.86	46.1	1.82	5.29	11.67
		19	1.05	213.0	8.39	203.9	8.03	151.4	5.96			5.42	11.96
		22	1.21	218.0	8.58	208.9	8.22	153.9	6.06			5.54	12.22
		26	1.43	223.8	8.81	214.7	8.45	156.8	6.17			5.75	12.68
		31	1.71	229.1	9.02	218.0	8.58	158.5	6.25			5.86	12.93
8	0.44	16	0.88	214.2	8.43	203.1	8.00	153.1	6.03	48.2	1.90	5.43	11.98
		19	1.05	219.2	8.63	208.1	8.19	155.6	6.13			5.57	12.29
		22	1.21	224.2	8.83	213.1	8.39	158.1	6.22			5.71	12.60
		26	1.43	230.0	9.06	218.9	8.62	161.0	6.34			5.85	12.91
		31	1.71	233.3	9.19	222.2	8.75	162.7	6.41			5.97	13.17
11	0.61	16	0.88	218.3	8.59	207.2	8.16	157.2	6.19	50.2	1.98	5.54	12.22
		19	1.05	223.3	8.79	212.2	8.35	159.7	6.29			5.69	12.55
		22	1.21	228.3	8.99	217.2	8.55	162.2	6.39			5.82	12.84
		26	1.43	234.1	9.22	223.0	8.78	165.1	6.50			5.98	13.19
		31	1.71	235.4	9.27	226.3	8.91	166.8	6.57			6.17	13.61
14	0.77	16	0.88	223.3	8.79	212.2	8.35	162.2	6.39	52.7	2.07	5.69	12.55
		19	1.05	228.3	8.99	217.2	8.55	164.7	6.48			5.81	12.82
		22	1.21	233.3	9.19	222.2	8.75	167.2	6.58			5.94	13.10
		26	1.43	239.1	9.41	228.0	8.98	170.1	6.70			6.08	13.41
		31	1.71	240.4	9.46	231.3	9.11	171.8	6.77			6.20	13.68

Nota - Per accoppiamenti di cilindrate differenti e relative dimensioni contattare il servizio commerciale.

*Note - For different couplings of displacements and related dimensions please contact our Sales Dpt.*

## POMPE MULTIPLE AD INGRANAGGI MULTIPLE GEAR PUMPS

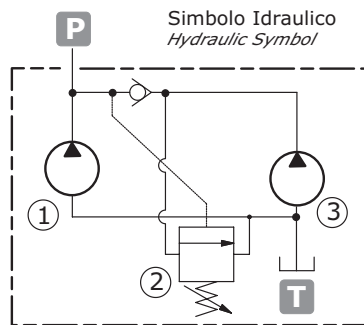
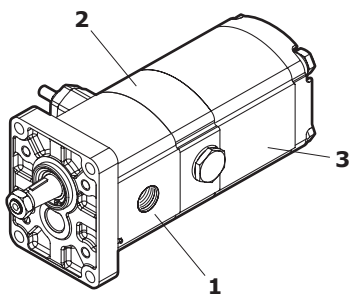
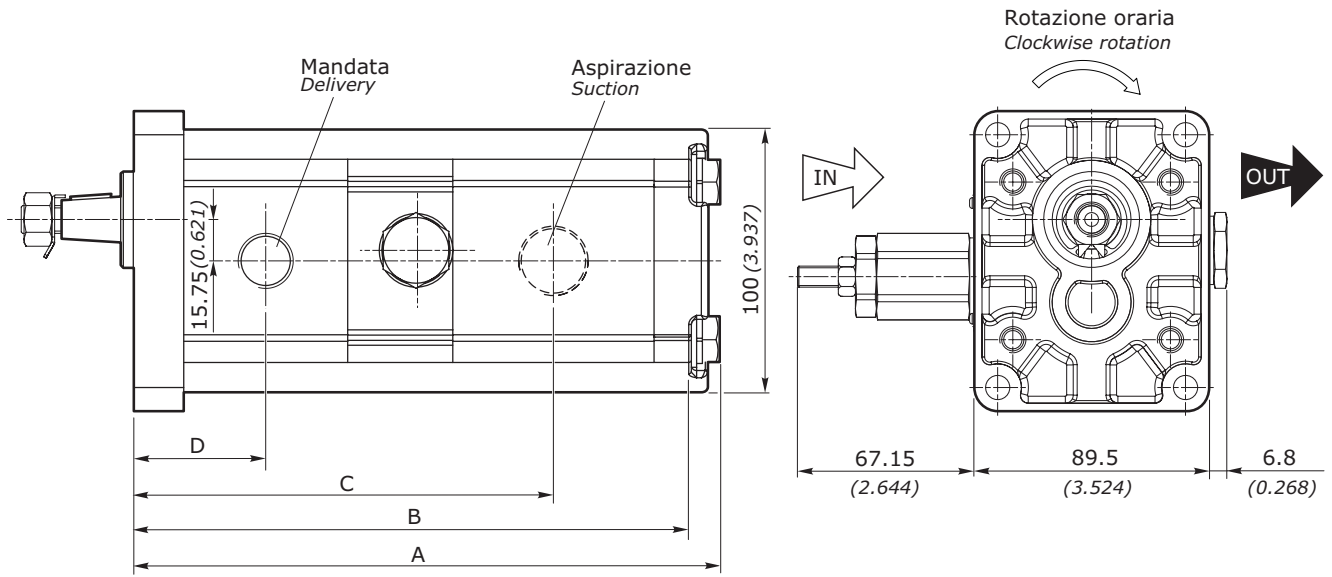

- 1** Stadio alta pressione  
Stage high pressure
- 2** Flangia intermedia con valvola disgiuntrice  
Intermediate flange with high low pump
- 3** Stadio bassa pressione  
Stage low pressure

esempio • example: **2SP - A - 110 - D - EUR - B - N - 10 - 0 - G / VD 100 / 2SP - A - 140 - 0 - G**

**VD** = Valvola disgiuntrice / High low pump

**100** = Campo di Taratura 25÷100 (bar) / Setting range 25÷100 (bar)

**POMPE MULTIPLE AD INGRANAGGI  
MULTIPLE GEAR PUMPS**

**CODICE ORDINAZIONE • ORDER CODE**

**POMPA DOPPIA • DOUBLE PUMP  
3GP + 1SP**

PRIMA POMPA  
FIRST PUMP

SECONDA POMPA  
SECOND PUMP

**3GP - G - 340 - D - EUR - B - N - 10 - 0 - G / TS / 1SP - A - 020 - 0 - G**

KIT INTERMEDIO  
INTERMEDIATE KIT

SIGLA - CODE	TIPO - TYPE	DESCRIZIONE - DESCRIPTION	PAGINA - PAGE	
PRIMA POMPA - FIRST PUMP	<b>3GP</b>	Tipo pompa <i>Pump type</i>	Pompa singola - gruppo 3 <i>Single pump - group 3</i>	6
	<b>G</b>	Materiale flangia e coperchio <i>Flange and cover material</i>	<b>G</b> = ghisa / cast iron	
	<b>340</b>	Cilindrata <i>Displacement</i>	Cilindrata = 33,8 cm <sup>3</sup> /giro <i>Displacement = 2.1 in<sup>3</sup>/rev</i>	6
	<b>D</b>	Senso di rotazione <i>Rotation wise</i>	<b>D</b> = Rotazione destra / <i>Clockwise rotation</i> <b>S</b> = Rotazione sinistra / <i>Anticlockwise rotation</i> <b>R</b> = Reversibile / <i>Reversible</i>	8
	<b>EUR</b>	Tipo Flangia <i>Flange type</i>	Flangia europea standard <i>Standard European flange</i>	72
	<b>B</b>	Tipo anello di tenuta <i>Seal ring type</i>	Vedi tabella compatibilità <i>See compatibility table</i>	
	<b>N</b>	Tipo guarnizione <i>Gasket type</i>	<b>N</b> = NBR <b>V</b> = Viton	73
	<b>10</b>	Tipo Albero <i>Shaft type</i>	Vedi tabella compatibilità <i>See compatibility table</i>	
	<b>0</b>	Posizione connessione <i>Connection position</i>	Vedi tabella compatibilità <i>See compatibility table</i>	75
<b>G</b>	Tipo connessione <i>Connection type</i>	Vedi tabella compatibilità <i>See compatibility table</i>	76	
<b>TS</b>	Tipo TANDEM <i>TANDEM type</i>	<b>TS</b> = Tandem Standard / <i>Standard tandem</i> <b>TC</b> = Tandem Corto / <i>Short tandem</i>		
SECONDA POMPA - SECOND PUMP	<b>1SP</b>	Tipo pompa <i>Pump type</i>	Pompa singola - gruppo 1 <i>Single pump - group 1</i>	4
	<b>A</b>	Materiale flangia e coperchio <i>Flange and cover material</i>	<b>A</b> = alluminio / <i>aluminium</i>	
	<b>020</b>	Cilindrata <i>Displacement</i>	Cilindrata = 2 cm <sup>3</sup> /giro <i>Displacement = 0.12 in<sup>3</sup>/rev</i>	4
	<b>0</b>	Posizione connessione <i>Connection position</i>	Vedi tabella compatibilità <i>See compatibility table</i>	29
	<b>G</b>	Tipo connessione <i>Connection type</i>	Vedi tabella compatibilità <i>See compatibility table</i>	30

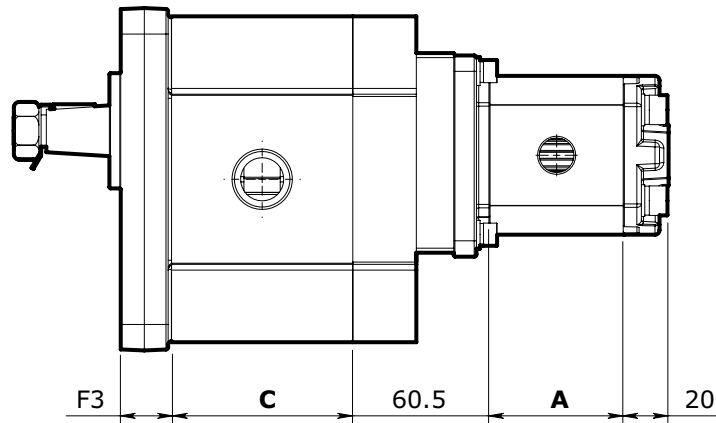
**POMPE MULTIPLE AD INGRANAGGI  
MULTIPLE GEAR PUMPS**
**DIMENSIONI • DIMENSIONS**
**TANDEM STANDARD TS • TS STANDARD TANDEM**

**TANDEM CORTO TC • TC SHORT TANDEM**

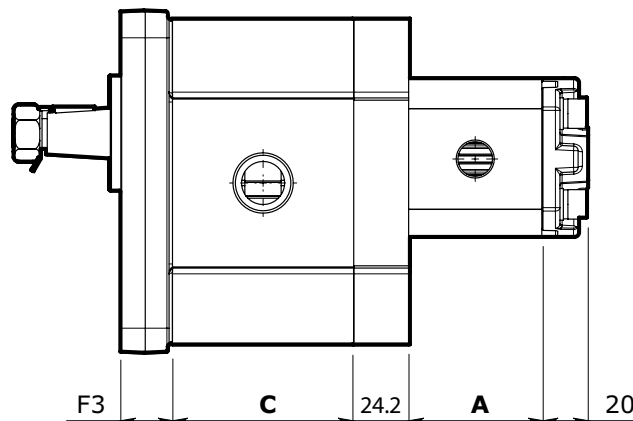
Le dimensioni sono le stesse per tandem corto con aspirazione unica **..M/..U.** *Dimensions are the same for tandem short with common suction **..M/..U.***



<b>1SP</b>		CILINDRATA - DISPLACEMENT											
		<b>009</b>	<b>012</b>	<b>016</b>	<b>020</b>	<b>025</b>	<b>032</b>	<b>037</b>	<b>042</b>	<b>050</b>	<b>063</b>	<b>078</b>	<b>098</b>
<b>A</b>	mm	37.6	38.7	40.4	41.9	43.9	46.6	48.6	50.0	53.6	58.7	64.4	72.3
	in	1.48	1.52	1.59	1.65	1.73	1.83	1.91	1.99	2.11	2.31	2.54	2.85

<b>3GP</b>		CILINDRATA - DISPLACEMENT									
		<b>190</b>	<b>230</b>	<b>300</b>	<b>340</b>	<b>370</b>	<b>440</b>	<b>530</b>	<b>620</b>	<b>700</b>	<b>770</b>
<b>C</b>	mm	79.9	82.9	88.9	91.9	94.9	100.9	107.9	115.9	112.5	127.9
	in	3.15	3.26	3.50	3.62	3.74	3.97	4.25	4.56	4.82	5.04

<b>3GP</b>		FLANGIA - FLANGE		
		<b>EUR</b>	<b>SAEB*</b>	<b>ZFC</b>
<b>F3</b>	mm	22.4	22.4	70.5
	in	0.88	0.88	2.78

\* Contattare il servizio commerciale. /Available soon. Please contact our Sales Dpt.



**POMPE MULTIPLE AD INGRANAGGI**  
**MULTIPLE GEAR PUMPS**

**CODICE ORDINAZIONE • ORDER CODE**

**POMPA DOPPIA • DOUBLE PUMP**  
**3GP + 2SP**

PRIMA POMPA  
FIRST PUMP

SECONDA POMPA  
SECOND PUMP

**3GP - G - 340 - D - EUR - B - N - 10 - 0 - G / TS / 2SP - A - 140 - 0 - G**

KIT INTERMEDIO  
INTERMEDIATE KIT

SIGLA - CODE	TIPO - TYPE	DESCRIZIONE - DESCRIPTION	PAGINA - PAGE	
PRIMA POMPA - FIRST PUMP	<b>3GP</b>	Tipo pompa <i>Pump type</i>	Pompa singola - gruppo 3 <i>Single pump - group 3</i>	6
	<b>G</b>	Materiale flangia e coperchio <i>Flange and cover material</i>	<b>G</b> = ghisa / cast iron	
	<b>340</b>	Cilindrata <i>Displacement</i>	Cilindrata = 33.8 cm <sup>3</sup> /giro <i>Displacement = 2.1 in<sup>3</sup>/rev</i>	6
	<b>D</b>	Senso di rotazione <i>Rotation wise</i>	<b>D</b> = Rotazione destra / <i>Clockwise rotation</i> <b>S</b> = Rotazione sinistra / <i>Anticlockwise rotation</i> <b>R</b> = Reversibile / <i>Reversible</i>	8
	<b>EUR</b>	Tipo Flangia <i>Flange type</i>	Flangia europea standard <i>Standard European flange</i>	72
	<b>B</b>	Tipo anello di tenuta <i>Seal ring type</i>	Vedi tabella compatibilità <i>See compatibility table</i>	
	<b>N</b>	Tipo guarnizione <i>Gasket type</i>	<b>N</b> = NBR <b>V</b> = Viton	73
	<b>10</b>	Tipo Albero <i>Shaft type</i>	Vedi tabella compatibilità <i>See compatibility table</i>	
	<b>0</b>	Posizione connessione <i>Connection position</i>	Vedi tabella compatibilità <i>See compatibility table</i>	75
<b>G</b>	Tipo connessione <i>Connection type</i>	Vedi tabella compatibilità <i>See compatibility table</i>	76	
<b>TS</b>	Tipo TANDEM <i>TANDEM type</i>	<b>TS</b> = Tandem Standard / <i>Standard tandem</i> <b>TC</b> = Tandem Corto / <i>Short tandem</i> <b>..M/..U*</b> = Tandem Corto con aspirazione unica / <i>Tandem short with common suction</i>		
SECONDA POMPA - SECOND PUMP	<b>2SP</b>	Tipo pompa <i>Pump type</i>	Pompa singola - gruppo 2 <i>Single pump - group 2</i>	5
	<b>A</b>	Materiale flangia e coperchio <i>Flange and cover material</i>	<b>A</b> = alluminio / <i>aluminium</i>	
	<b>140</b>	Cilindrata <i>Displacement</i>	Cilindrata = 14 cm <sup>3</sup> /giro <i>Displacement = 0.85 in<sup>3</sup>/rev</i>	5
	<b>0</b>	Posizione connessione <i>Connection position</i>	Vedi tabella compatibilità <i>See compatibility table</i>	57
	<b>G</b>	Tipo connessione <i>Connection type</i>	Vedi tabella compatibilità <i>See compatibility table</i>	58

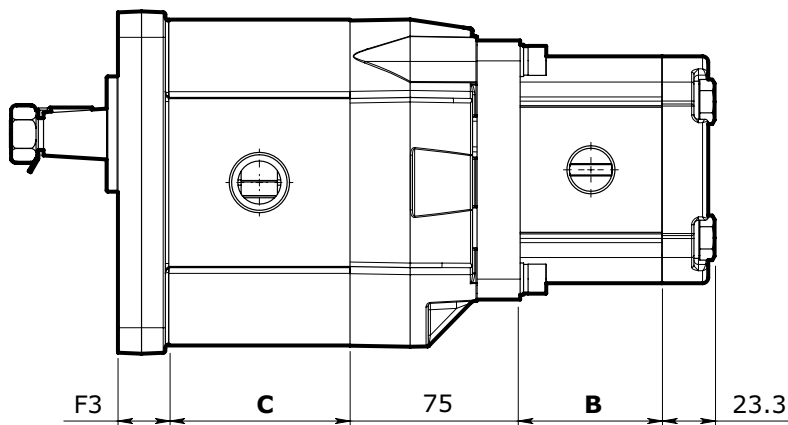
**POMPE MULTIPLE AD INGRANAGGI  
MULTIPLE GEAR PUMPS**
**DIMENSIONI • DIMENSIONS**
**TANDEM STANDARD TS • TS STANDARD TANDEM**

**TANDEM CORTO TC • TC SHORT TANDEM**

Le dimensioni sono le stesse per tandem corto con aspirazione unica ..M/..U.

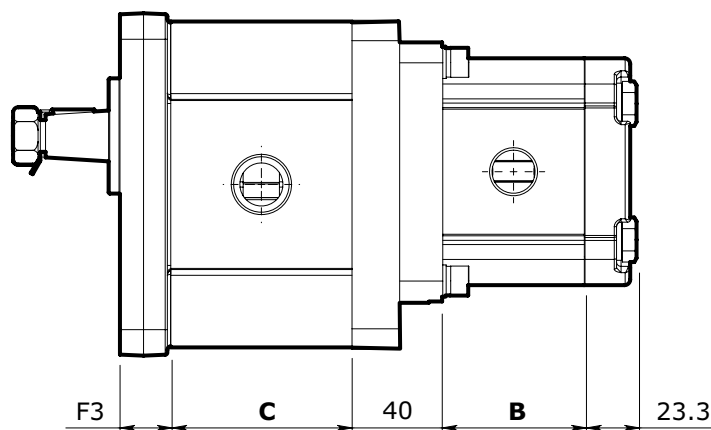
Dimensions are the same for tandem short with common suction ..M/..U.



<b>2SP</b>		CILINDRATA - DISPLACEMENT									
		<b>040</b>	<b>060</b>	<b>080</b>	<b>110</b>	<b>140</b>	<b>160</b>	<b>190</b>	<b>220</b>	<b>260</b>	<b>310</b>
<b>B</b>	mm	50.8	54.1	58.3	62.4	67.4	71.6	76.6	81.6	87.4	95.8
	in	2.00	2.13	2.30	2.46	2.65	2.82	3.02	3.21	3.44	3.77

<b>3GP</b>		CILINDRATA - DISPLACEMENT									
		<b>190</b>	<b>230</b>	<b>300</b>	<b>340</b>	<b>370</b>	<b>440</b>	<b>530</b>	<b>620</b>	<b>700</b>	<b>770</b>
<b>C</b>	mm	79.9	82.9	88.9	91.9	94.9	100.9	107.9	115.9	112.5	127.9
	in	3.15	3.26	3.50	3.62	3.74	3.97	4.25	4.56	4.82	5.04

<b>3GP</b>		FLANGIA - FLANGE		
		<b>EUR</b>	<b>SAEB*</b>	<b>ZFC</b>
<b>F3</b>	mm	22.4	22.4	70.5
	in	0.88	0.88	2.78

\* Contattare il servizio commerciale. / Available soon.  
Please contact our Sales Dpt.

(\*) - Per descrizione tandem corto con aspirazione unica vedere pag. 82. Contattare il Servizio Commerciale per combinazioni e flange disponibili.

(\*) - For Tandem short with common suction see page 82. Please contact our Sales Dpt for available combinations and flanges.

**POMPE MULTIPLE AD INGRANAGGI  
MULTIPLE GEAR PUMPS**

**CODICE ORDINAZIONE • ORDER CODE**

**POMPA DOPPIA • DOUBLE PUMP  
3GP + 3GP**

PRIMA POMPA  
FIRST PUMP

SECONDA POMPA  
SECOND PUMP

**3GP - G - 340 - D - EUR - B - N - 10 - 0 - G / TS / 3GP - G - 340 - 0 - G**

KIT INTERMEDIO  
INTERMEDIATE KIT

SIGLA - CODE	TIPO - TYPE	DESCRIZIONE - DESCRIPTION	PAGINA - PAGE	
PRIMA POMPA - FIRST PUMP	<b>3GP</b>	Tipo pompa <i>Pump type</i>	Pompa singola - gruppo 3 <i>Single pump - group 3</i>	6
	<b>G</b>	Materiale flangia e coperchio <i>Flange and cover material</i>	<b>G</b> = ghisa / cast iron	
	<b>340</b>	Cilindrata <i>Displacement</i>	Cilindrata = 33.8 cm <sup>3</sup> /g <i>Displacement = 2.1 in<sup>3</sup>/rev</i>	6
	<b>D</b>	Senso di rotazione <i>Rotation wise</i>	<b>D</b> = Rotazione destra / <i>Clockwise rotation</i> <b>S</b> = Rotazione sinistra / <i>Anticlockwise rotation</i>	8
	<b>EUR</b>	Tipo Flangia <i>Flange type</i>	Flangia europea standard <i>Standard European flange</i>	72
	<b>B</b>	Tipo anello di tenuta <i>Seal ring type</i>	Vedi tabella compatibilità <i>See compatibility table</i>	
	<b>N</b>	Tipo guarnizione <i>Gasket type</i>	<b>N</b> = NBR <b>V</b> = Viton	73
	<b>10</b>	Tipo Albero <i>Shaft type</i>	Vedi tabella compatibilità <i>See compatibility table</i>	
	<b>0</b>	Posizione connessione <i>Connection position</i>	Vedi tabella compatibilità <i>See compatibility table</i>	75
<b>G</b>	Tipo connessione <i>Connection type</i>	Vedi tabella compatibilità <i>See compatibility table</i>	76	
<b>TS</b>	Tipo TANDEM <i>TANDEM type</i>	<b>TS</b> = Tandem Standard / <i>Standard tandem</i> <b>TC</b> = Tandem Corto / <i>Short tandem</i> <b>..M/..U*</b> = Tandem Corto con aspirazione unica / <i>Tandem short with common suction</i>		
	<b>3GP</b>	Tipo pompa <i>Pump type</i>	Pompa singola - gruppo 3 <i>Single pump - group 3</i>	6
	<b>G</b>	Materiale flangia e coperchio <i>Flange and cover material</i>	<b>G</b> = ghisa / cast iron	
	<b>340</b>	Cilindrata <i>Displacement</i>	Cilindrata = 33.8 cm <sup>3</sup> /giro <i>Displacement = 2.1 in<sup>3</sup>/rev</i>	6
	<b>0</b>	Posizione connessione <i>Connection position</i>	Vedi tabella compatibilità <i>See compatibility table</i>	75
	<b>G</b>	Tipo connessione <i>Connection type</i>	Vedi tabella compatibilità <i>See compatibility table</i>	76

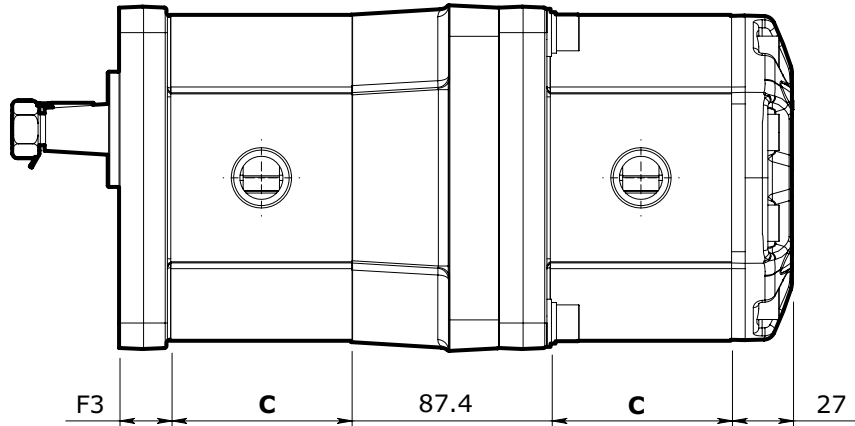
**POMPE MULTIPLE AD INGRANAGGI  
MULTIPLE GEAR PUMPS**
**DIMENSIONI • DIMENSIONS**
**TANDEM STANDARD TS • TS STANDARD TANDEM**

**TANDEM CORTO TC • TC SHORT TANDEM**

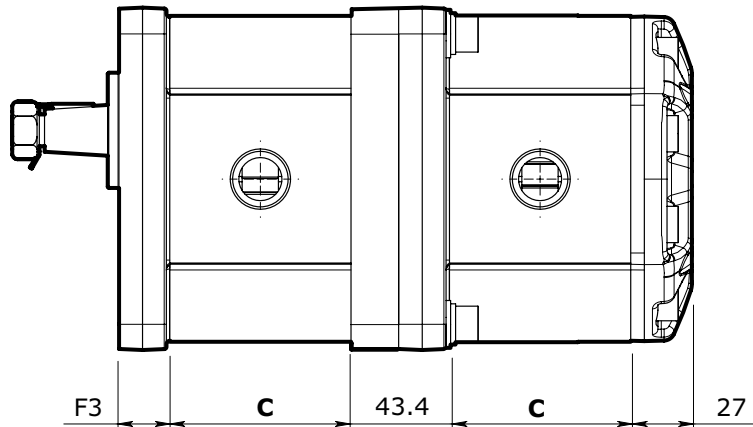
Le dimensioni sono le stesse per tandem corto con aspirazione unica ..M/..U. *Dimensions are the same for tandem short with common suction ..M/..U.*



<b>3GP</b>		CILINDRATA - DISPLACEMENT									
		<b>190</b>	<b>230</b>	<b>300</b>	<b>340</b>	<b>370</b>	<b>440</b>	<b>530</b>	<b>620</b>	<b>700</b>	<b>770</b>
<b>C</b>	mm	79.9	82.9	88.9	91.9	94.9	100.9	107.9	115.9	112.5	127.9
	in	3.15	3.26	3.50	3.62	3.74	3.97	4.25	4.56	4.82	5.04

<b>3GP</b>		FLANGIA - FLANGE		
		<b>EUR</b>	<b>SAEB*</b>	<b>ZFC</b>
<b>F3</b>	mm	22.4	22.4	70.5
	in	0.88	0.88	2.78

\* Contattare il servizio commerciale. / Available soon.  
Please contact our Sales Dpt.

(\*) - Per descrizione tandem corto con aspirazione unica vedere pag. 82. Contattare il Servizio Commerciale per combinazioni e flange disponibili.

(\*) - For Tandem short with common suction see page 82. Please contact our Sales Dpt for available combinations and flanges.

**MOTORI AD INGRANAGGI  
GEAR MOTORS**

**INTRODUZIONE • INTRODUCTION**

Il motore ad ingranaggi esterni è un componente utilizzato per applicazioni oleodinamiche dove all'albero è richiesta una buona erogazione di coppia. La semplicità nella costruzione (rispetto ad altre tipologie di motori più complessi come ad esempio motori orbitali o a pistoni) unita alla grande versatilità, resistenza e lunga durata consentono una manutenzione ridotta e costi d'acquisto più contenuti.

Tali motori possono sia lavorare in condizioni gravose con elevate potenze idrauliche, sia in condizioni standard con una bassa emissione acustica ed elevati rendimenti idromeccanici e volumetrici grazie all'ottima bilanciatura.

La gamma Galtech grazie un costante lavoro di ricerca unito all'esperienza pluriennale, alla meticolosa scelta dei materiali e alla costante cura nel processo non solo di produzione, ma anche nei test di validazione si è ampliata mantenendo elevati standard qualitativi.

I motori ad ingranaggi esterni sono costituiti da 3 gruppi: 1SM, 2SM e 3GM con 20 cilindrata da 0.89 a 77.2 cc/giro adatte alle più variate applicazioni sia industriali che nel campo del mobile con elevati rapporti potenza/peso e potenza/dimensioni. Si possono raggiungere pressioni elevate fino a 270 bar e una velocità massima di rotazione di 4000 giri/min. Sia nella versione monodirezionale che bidirezionale i motori Galtech possono essere assemblati con totale intercambiabilità sia con flange standard (europea, tedesca, SAE) sia con tipologie speciali ed utilizzare una vasta gamma di alberi come quelli conici, cilindrici scanalati e con dente frontale. Sono disponibili vari coperchi e flange in ghisa per ridurre la rumorosità e aumentare i limiti operativi. Inoltre è possibile montare coperchi valvola limitatrice di pressione anche per la regolazione a due velocità.

*External gear motor is a component used for hydraulic applications where a good torque output is required to the shaft. Simple construction (compared with other types of more complex motors such as orbital or piston motors) and great versatility, durability and endurance allow to reduce maintenance and to lower the purchasing costs.*

*These motors can work both under heavy operating conditions with high hydraulic power outputs or in standard conditions with a low noise level and high hydromechanical and volumetric efficiencies by means of an excellent balancing.*

*Galtech range has been increased maintaining high quality standards by means of constant research combined with years of experience, meticulous choice of materials and constant care not only in the production processes but also in the validation tests.*

*External gear motor range present 3 groups: 1SM, 2SM and 3GM with 20 displacement sizes from 0.89 to 77.2 cc/rev. high pressures up to 270 bar and a maximum speed of 4000 RPM. These motors can be used for different industrial and mobile applications with good power/weight and power/size ratios.*

*Both unidirectional and bidirectional Galtech motors can be assembled with a full interchangeability with standard flanges (European, German, SAE) or with special types.*

*A wide variety of shafts can be used: tapered, splined, parallel and with dihedral claw. Cast iron covers and flanges are available to reduce noise level and to increase the operating limits. It is also possible to assemble covers with pressure relief valve for two-speed adjustment*

Le cilindrata disponibili sono evidenziate nel seguente diagramma (cm<sup>3</sup>/giro):  
Available displacements are shown below (cm<sup>3</sup>/rev):

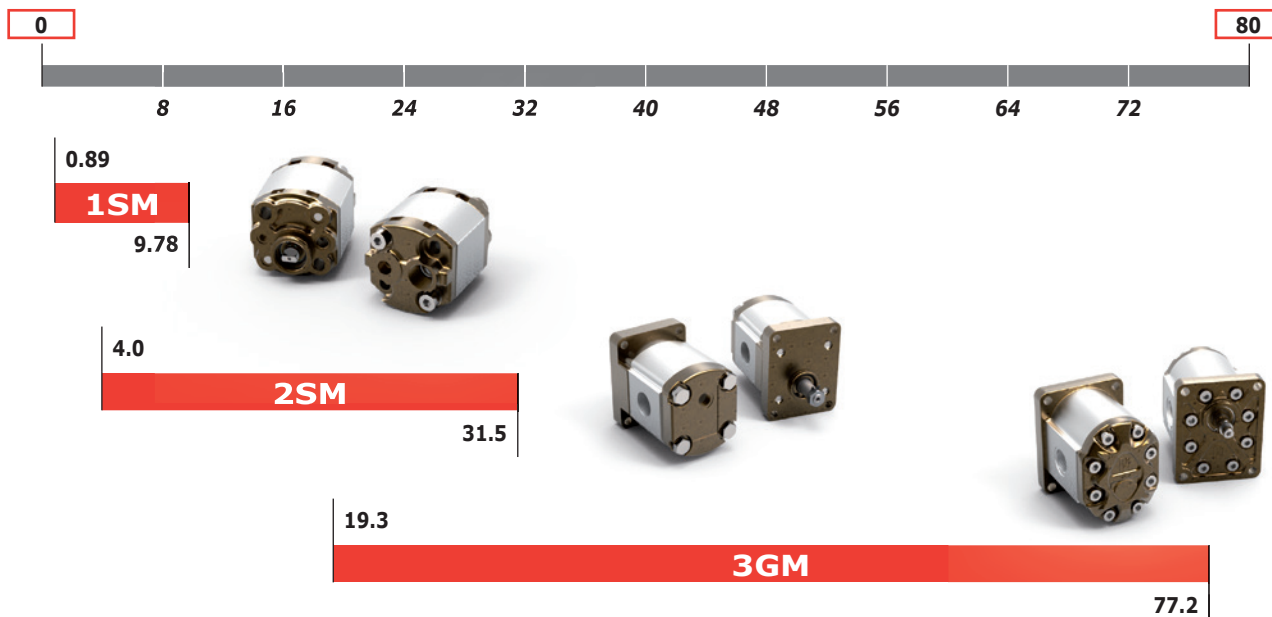

**MOTORI AD INGRANAGGI GAMMA PRODOTTO**  
**GEAR MOTORS PRODUCT RANGE**

GRUPPO GROUP <b>1SM</b>	CILINDRATA DISPLACEMENT		VELOCITÀ MAX MAX SPEED	PORTATA MAX MAX FLOW		VELOCITÀ MIN MIN SPEED	PORTATA MIN MIN FLOW	
	cm <sup>3</sup> /giro	in <sup>3</sup> /rev	giri/min - rpm	l/min	Gal/min	giri/min - rpm	l/min	Gal/min
<b>1SM 009</b>	0.89	0.05	6000	5.3	1.40	600	0.49	0.13
<b>1SM 012</b>	1.18	0.07	6000	7.1	1.88	600	0.65	0.17
<b>1SM 016</b>	1.6	0.10	6000	9.6	2.54	400	0.61	0.16
<b>1SM 020</b>	2.0	0.12	5500	11	2.91	400	0.76	0.20
<b>1SM 025</b>	2.5	0.15	5000	12.5	3.30	400	0.95	0.25
<b>1SM 032</b>	3.2	0.20	4500	14.4	3.80	400	1.21	0.32
<b>1SM 037</b>	3.7	0.23	4000	14.8	3.91	400	1.40	0.37
<b>1SM 042</b>	4.2	0.26	3500	14.7	3.88	400	1.60	0.42
<b>1SM 050</b>	5.0	0.31	3000	15	3.96	400	1.90	0.50
<b>1SM 063</b>	6.3	0.38	2700	17	4.49	400	2.39	0.63
<b>1SM 078</b>	7.76	0.47	2500	19.4	5.13	400	2.95	0.78
<b>1SM 098</b>	9.78	0.60	2000	19.6	5.18	400	3.71	0.98

## FLANGE - FLANGES

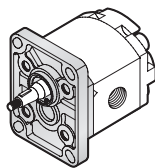
**EUR**

pagina/page 113

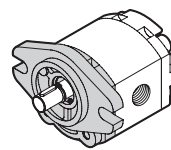
**SAEAA**

pagina/page 114

**VERSIONI DISPONIBILI • AVAILABLE VERSIONS**

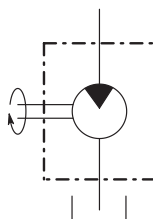
 Motore unidirezionale (D-S)  
 Unidirectional motor (D-S)

**MOTORI AD INGRANAGGI GAMMA PRODOTTO**  
**GEAR MOTORS PRODUCT RANGE**

GRUPPO GROUP 2SM	CILINDRATA DISPLACEMENT		VELOCITÀ MAX MAX SPEED	PORTATA MAX MAX FLOW		VELOCITÀ MIN MIN SPEED	PORTATA MIN MIN FLOW	
	cm <sup>3</sup> /giro	in <sup>3</sup> /rev	giri/min - rpm	l/min	Gal/min	giri/min - rpm	l/min	Gal/min
<b>2SM 040</b>	4	0.24	4000	16	4.23	500	1.9	0.50
<b>2SM 060</b>	6	0.37	4000	24	6.34	500	2.85	0.75
<b>2SM 080</b>	8.5	0.52	3500	29.7	7.85	500	4.03	1.06
<b>2SM 110</b>	11	0.67	3500	38.5	10.17	500	5.22	1.38
<b>2SM 140</b>	14	0.85	3500	49	12.95	500	6.65	1.76
<b>2SM 160</b>	16.5	1.01	3500	57.7	15.24	500	7.83	2.07
<b>2SM 190</b>	19.5	1.19	3300	64.3	16.99	500	9.26	2.45
<b>2SM 220</b>	22.5	1.37	2800	63	16.64	500	10.68	2.82
<b>2SM 260</b>	26	1.59	2500	65	17.17	500	12.35	3.26
<b>2SM 310</b>	31.5	1.92	2200	69	18.22	500	15.75	4.16

FLANGE - FLANGES

**EUR**

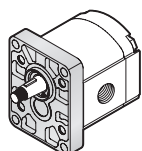

pagina/page 124

**SAEA**

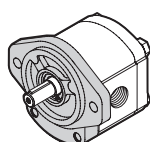

pagina/page 126

**SAEAOR**

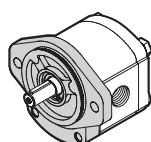

**B80C**

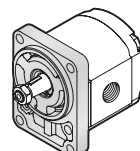

pagina/page 128

**B50C**

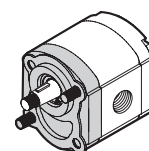

pagina/page 129

**E52C**

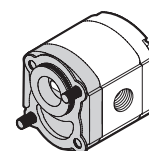

pagina/page 130

FLANGE - FLANGES

**SUPEUR**

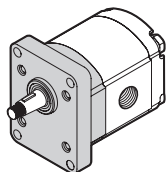

pagina/page 131

**SAEB\***

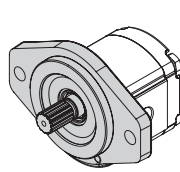

pagina/page 133

**SUPSAE**

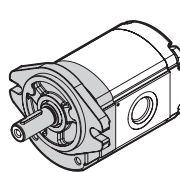

pagina/page 134

**SUPB80C**

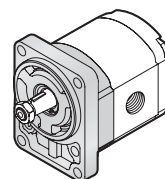

pagina/page 135

**SUPB50CX**

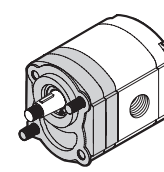

pagina/page 136

\* Contattare il servizio commerciale. / Available soon. Please contact our Sales Dpt.

**VERSIONI DISPONIBILI • AVAILABLE VERSIONS**

Motore unidirezionale (D-S)  
Unidirectional motor (D-S)

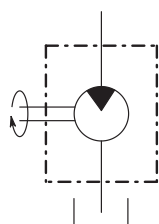

Motore reversibile con drenaggio esterno (R)  
Reversible motor with external drain (R)

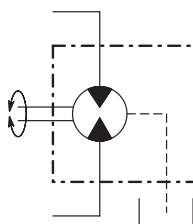

Motore reversibile con drenaggio interno (X)  
Reversible motor with internal drain (X)

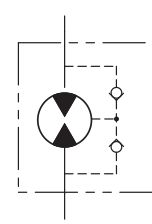

**MOTORI AD INGRANAGGI GAMMA PRODOTTO**  
**GEAR MOTORS PRODUCT RANGE**

GRUPPO GROUP <b>3GM</b>	CILINDRATA DISPLACEMENT		VELOCITÀ MAX MAX SPEED	PORTATA MAX MAX FLOW		VELOCITÀ MIN MIN SPEED	PORTATA MIN MIN FLOW	
	cm <sup>3</sup> /giro	in <sup>3</sup> /rev	giri/min - rpm	l/min	Gal/min	giri/min - rpm	l/min	Gal/min
<b>3GM 190</b>	19.3	1.2	3500	67.6	17.84	600	12.8	3.39
<b>3GM 230</b>	23.0	1.4	3500	80.3	21.22	600	15.5	4.03
<b>3GM 300</b>	30.2	1.8	3300	99.7	26.33	600	20.1	5.31
<b>3GM 340</b>	33.8	2.1	3300	111.6	29.49	600	22.5	5.94
<b>3GM 370</b>	37.5	2.3	3300	123.6	32.66	600	24.9	6.58
<b>3GM 440</b>	44.6	2.7	3000	133.8	35.35	600	29.7	7.84
<b>3GM 530</b>	53.0	3.2	3000	159.1	42.04	600	35.3	9.32
<b>3GM 620</b>	62.7	3.8	2500	156.8	41.41	600	41.7	11.01
<b>3GM 700</b>	70.5	4.3	2500	176.3	46.58	600	46.9	12.39
<b>3GM 770</b>	77.2	4.7	2200	169.8	44.84	600	51.3	13.56

## FLANGE - FLANGES

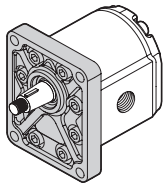
**EUR**

pagina/page 156

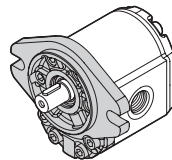
**SAEB\***

pagina/page 157

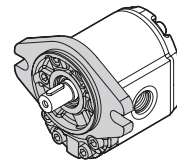
**SAEBOR\***

pagina/page 157

\* Contattare il servizio commerciale. / Available soon. Please contact our Sales Dpt.

**VERSIONI DISPONIBILI • AVAILABLE VERSIONS**

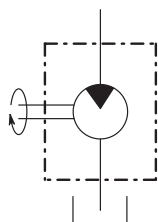
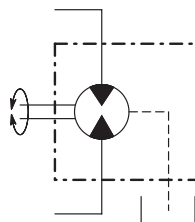
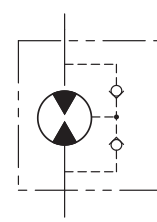
 Motore unidirezionale (D-S)  
 Unidirectional motor (D-S)

 Motore reversibile con drenaggio esterno (R)  
 Reversible motor with external drain (R)

 Motore reversibile con drenaggio interno (X)  
 Reversible motor with internal drain (X)



## MOTORI AD INGRANAGGI INFORMAZIONI TECNICHE

### GEAR MOTORS TECHNICAL INFORMATION

#### FLUIDI IDRAULICI • HYDRAULIC FLUIDS

È consigliabile utilizzare oli idraulici di origine minerale con buone caratteristiche antischiuma, antiusura, antiossidanti, anticorrosione e con proprietà di rapida disareazione ed elevato indice di viscosità;

- viscosità raccomandata 15÷92 mm<sup>2</sup>/s
- viscosità limite d'avviamento 2000 mm<sup>2</sup>/s

Durante il normale funzionamento la temperatura dell'olio dovrà essere compresa tra 20° C e 65° C con valori limite compresi tra -20° C e 80° C con le guarnizioni in NBR e -15° C e 100° C con le stesse in Viton.

*It is advisable to use hydraulic oils of mineral origin with anti-foaming, antiwear, anti-oxidant and anti-corrosion characteristics and rapid air removal properties and a high viscosity index;*

- *Recommended viscosity 15÷92 mm<sup>2</sup>/s (cSt)*
- *Start-up viscosity limit 2000 mm<sup>2</sup>/s (cSt)*

*During normal operation, the oil temperature must be between 20°C and 65°C with limit values between -20°C and 80°C with NBR gasket with limit values between -15°C and 100°C with Viton gasket.*

#### PRESSIONE DI DRENAGGIO • DRAINAGE PRESSURE

Qualora il drenaggio non fosse interno il limite massimo di pressione su tale linea è pari a 6 bar.

*Without external drain, 6 bar is the maximum counterpressure allowed is 6 bar.*

#### FILTRAZIONE • FILTRATION

Per eliminare eventuali impurità presenti nell'olio e garantire una durata superiore del motore, è necessario introdurre nell'impianto un'efficace filtrazione verificandone periodicamente la funzionalità.

I livelli di filtrazione raccomandati sono i seguenti:

Utilizzo fino a 150 bar:

**21/19/16 (ISO 4406) classe 10 (NAS 1638)**

Utilizzo oltre 150 bar:

**20/18/15 (ISO 4406) classe 9 (NAS 1638)**

*In order to eliminate any impurity present in the oil and to guarantee a longer duration of the motor, the system must be equipped with effective filtration which must be periodically checked to ensure that it is operating correctly.*

*The recommended filtration levels are the following:*

*Up to 150 bar:*

**21/19/16 (ISO 4406) classe 10 (NAS 1638)**

*Over 150 bar:*

**20/18/15 (ISO 4406) classe 9 (NAS 1638)**

#### NOTE INSTALLAZIONE • INSTALLATION NOTES

Prima di avviare l'impianto a regime, sono consigliati alcuni accorgimenti:

- Verificare in caso di motore unidirezionale, che il senso di rotazione sia coerente con il lato da cui proviene l'alimentazione.
- Verificare che nelle flange di connessione alle porte di mandata non siano presenti trucioli, sporco o altro.
- Se il motore è sottoposto a verniciatura, proteggere l'anello di tenuta verificando anche che la zona di contatto fra anello di tenuta e albero sia priva di polvere o di sedimenti abrasivi che possono accelerare le usure e causare delle perdite.
- Assicurarsi che il giunto utilizzato per la trasmissione compensi disallineamenti assiali che potrebbero pregiudicare l'integrità del motore.
- In caso in cui il motore trasmetta dei carichi radiali e/o assiali sull'albero (come ad esempio quando trascina pulegge e cinghie) è necessario optare per le versioni con supporto rinforzato.
- Il giunto di collegamento fra alberi scanalati dovrà essere lubrificato, libero di muoversi assialmente e di lunghezza adatta a coprire tutta l'estensione dei due alberi (motore e pompa).

##### **Durante il primo avviamento:**

- scollegare lo scarico della pompa di alimentazione per permettere di spurgare l'aria nel circuito e, in caso di valvole di massima, tarare le valvole limitatrici di pressione al minimo valore.
- Evitare, in presenza di livelli di pressione di alimentazione superiori alla pressione massima continuativa, di sottoporre il motore ad un regime di rotazione inferiore a quello minimo consentito.
- Evitare partenze sotto carico in condizioni di bassa temperatura o di lunghi periodi di inattività.

*Before starting to set the system, some precautions are recommended:*

- *In case of a monodirectional motor, check for the direction of rotation to be consistent with the inlet side.*
- *Remove all dirt, chips and foreign bodies from flange connecting inlet and delivery ports.*
- *Protect the drive shaft sealing ring during pump painting; check that the contact area between ring and shaft is clean: dust or abrasive sediments could accelerate the wear and cause leakage.*
- *Make sure that the transmission joint balances any axial misalignment that might compromise the engine working.*
- *With radial and/or axial loads provided by the motor shaft (such as when it drives pulleys or chains) use the available versions with strengthen shaft.*
- *The coupling joint between the spline shafts has to be properly lubricated, free to move axially and of suitable length to cover both motor and pump shafts.*

##### **During first system working:**

- *Disconnect the drain pump to bleed off the air in the circuit and, set the pressure relief valve if present at the minimum value.*
- *Avoid lower rotation speed than min. allowed with an inlet pressure higher than the continuous max pressure.*
- *Do not start the system under load at low temperatures or after long stops.*
- *Check the whole system filling by bleeding off the whole air*

## MOTORI AD INGRANAGGI INFORMAZIONI TECNICHE GEAR MOTORS TECHNICAL INFORMATION

- Per verificare l'effettivo riempimento sfiatare il circuito dopo un primo avviamento di qualche istante dove è stata attivata tutta la componentistica.
- Tenendo controllata la temperatura del fluido e delle parti in movimento e la velocità di rotazione è infine possibile aumentare la pressione fino al raggiungimento delle condizioni di esercizio previste che devono mantenersi entro i limiti indicati nel presente catalogo.

amount after few minutes of system working.

- Increase the pressure until you reach the operating values by keeping checked the fluid and the moving parts temperature and the rotation speed. Maintain the set values within the limits indicated in this catalogue.

### DEFINIZIONE DEL VERSO DI ROTAZIONE GUARDANDO L'ALBERO DI TRASCINAMENTO DEFINITION OF ROTATION LOOKING AT THE DRIVE SHAFT

USCITA FLUIDO AD ALTA PRESSIONE  
HIGH PRESSURE FLUID EXIT

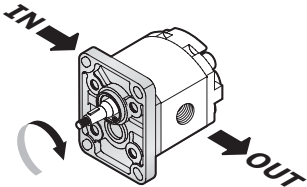
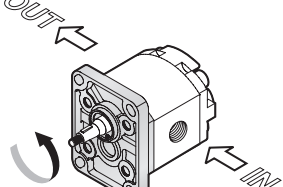
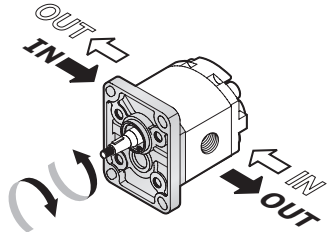
D ROTAZIONE DESTRA CLOCKWISE ROTATION	S ROTAZIONE SINISTRA ANTICLOCKWISE ROTATION	R ROTAZIONE REVERSIBILE CLOCKWISE ANTICLOCKWISE ROTATION
<p>Ingresso - alta pressione Inlet - high pressure</p>  <p>Scarico - bassa pressione Outlet - low pressure</p>	<p>Scarico - bassa pressione Outlet - low pressure</p>  <p>Ingresso - alta pressione Inlet - high pressure</p>	

### SENSO DI ROTAZIONE • ROTATION WISE

Il senso di rotazione viene definito S (sinistro) e D (destra) osservando l'albero frontalmente.

In caso di rotazione sinistra S lo scarico sarà a sinistra dell'albero mentre l'ingresso alla sua destra; il contrario sarà per motore monodirezionale destro.

Se i motori sono monodirezionali in fase di ordine è necessario precisare il senso di rotazione desiderato, oppure intervenire modificando l'assetto interno come illustrato di seguito (inversione del senso di rotazione).

The rotation wise is defined by observing the shaft frontally: S (anticlockwise) and D (clockwise).

In case of S anticlockwise rotation, outlet port will be the left of the shaft while inlet port to its right; the opposite layout is used in case of D clockwise rotation.

When ordering please specify the required rotation wise of monodirectional motors, otherwise modify the internal assembly layout as indicated below (wise rotation reversal).

### INVERSIONE • REVERSAL

Il senso di rotazione dei motori è evidenziato da una freccia sulla targhetta.

La targhetta è posizionata sul corpo. (vedi pagina 105)

L'inversione del senso di rotazione di un motore si esegue nel seguente modo:

- Smontare il motore come da figura 1.
- Sfilare gli ingranaggi C e D e rimontarli secondo la figura 2
- Rimontare la boccia B nella stessa posizione della figura 1
- Capovolgere la flangia A e rimontare il motore serrando le viti con una chiave dinamometrica.
- Per i motori 3GM, smontare solo la flangia anteriore.

Motor wise rotation is indicated by an arrow on the label.

The plate is placed on the body (see page 105).

How to invert the motor wise rotation:

- Disassemble motor as shown in figure 1.
- Pull off C-D gears and reassemble them according to figure 2.
- Reassemble bushing B as before.
- Reverse the flange A and reassemble the motor tightening the screws by dynamometric wrench.
- For the motors 3GM, disassemble only front flange.

**MOTORI AD INGRANAGGI INFORMAZIONI TECNICHE**  
**GEAR MOTORS TECHNICAL INFORMATION**

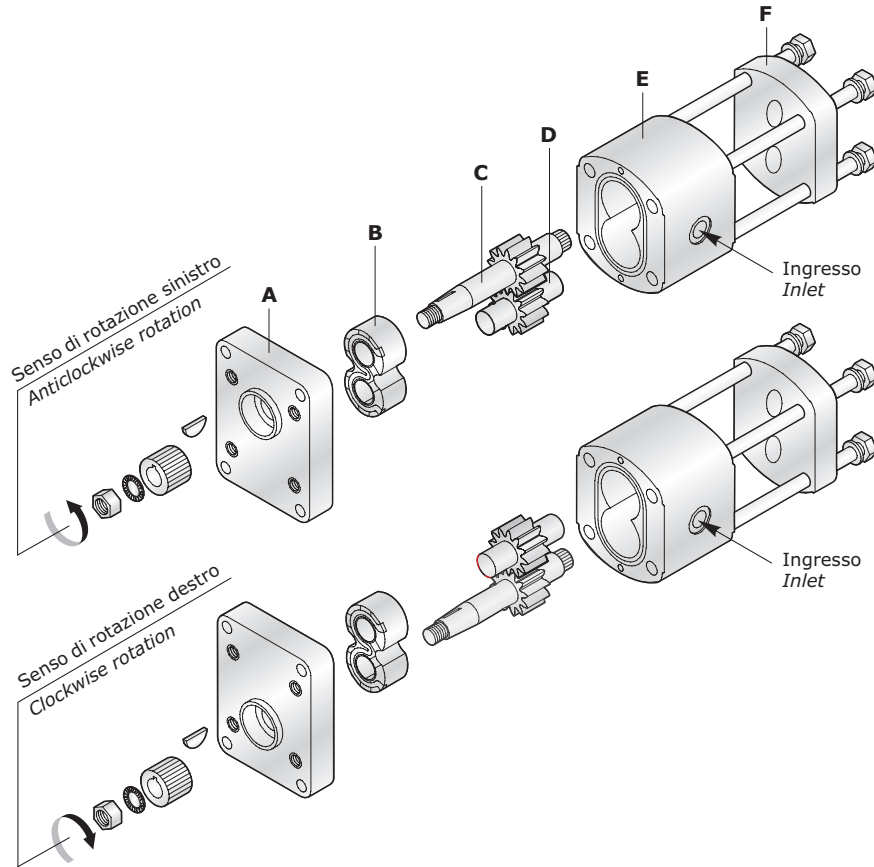
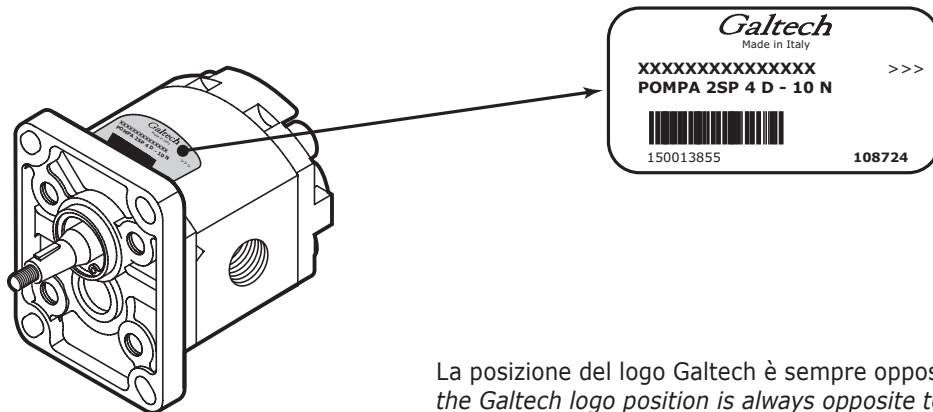

Fig. 1

Fig. 2

**TARGHETTA • PLATE**



La posizione del logo Galtech è sempre opposta alla flangia.  
 the Galtech logo position is always opposite to the flange.

Codice prodotto - Product code	XXXXXXXXXXXXXXXXXX	>>>	Senso di rotazione - Rotation wise:
Descrizione - Description	POMPA 2SP 4 D - 10 N		>>> = D <<< = S <> = R
Codice a barre - Bar code			
Anno produzione - Production year	150013855	108724	Numero ordine - Order number

**MOTORI AD INGRANAGGI INFORMAZIONI TECNICHE**  
**GEAR MOTORS TECHNICAL INFORMATION**

TIPO DI MOTORE - MOTOR TYPE	GRUPPO - GROUP 1SM	GRUPPO - GROUP 2SM	GRUPPO - GROUP 3GM
<b>Numero di viti</b> <i>Screw number</i>	4	4	16
<b>Tipo di filetto</b> <i>Thread type</i>	M8	M10	M10
<b>Coppia di serraggio viti</b> <i>Screw tightening torque</i>	30 Nm / 266 in-lbs	50 Nm / 443 in-lbs	60 Nm / 531 in-lbs
<b>Tipo di giunto</b> <i>Coupling type</i>	1IS 12M	2IS 14M / 2IS 15M	3IS 18M
<b>Coppia di serraggio dado giunto</b> <i>nut coupling tightening torque</i>	9 ÷ 10 Nm / 80 ÷ 90 in-lbs	22 ÷ 25 Nm / 195 ÷ 221 in-lbs 32 ÷ 35 Nm / 283 ÷ 310 in-lbs	50 ÷ 55 Nm / 443 ÷ 487 in-lbs

**DEFINIZIONE DELLE PRESSIONI • PRESSURE DEFINITION**

I motori possono essere sottoposti alle pressioni P1, P2, indicate nelle tabelle delle prestazioni.

Il grafico seguente ne illustra le definizioni e l'applicabilità rispettando i limiti delle velocità di rotazione riportati.

The motors can be subjected to the pressures P1, P2 indicated in the performance tables.

The following diagram illustrates their definitions and applicability, compared to the rotation speed limits included.

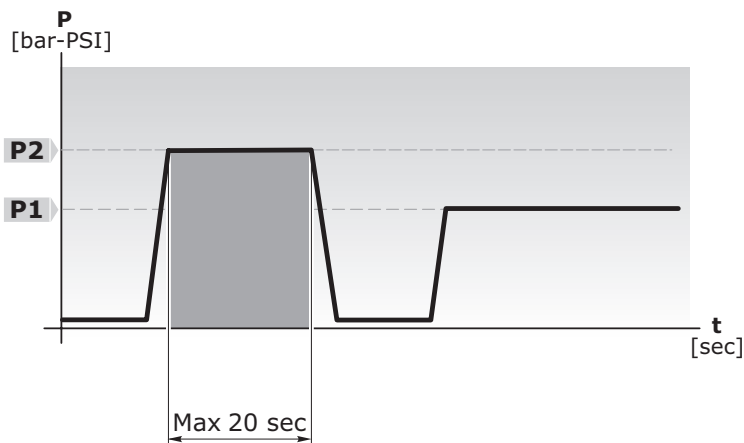

**P2** Pressione massima intermittente  
*Max intermittent pressure*

**P1** Pressione massima continua  
*Continuos max pressure*

MISURE IDRAULICHE - HYDRAULIC MEASURES			FORMULE UTILI - USEFUL FORMULAS		FATTORE CONVERSIONE - CONVERSION FACTOR	
<b>Q</b>	Portata <i>Flow</i>	[l/min] [Gal/min]	$Q = \frac{V \cdot n}{1000 \cdot \eta_v}$	[l/min]	1 l/min	0.2641 US Gal/min
<b>M</b>	Coppia <i>Torque</i>	[Nm] [lbf.in]	$Q = \frac{V \cdot n}{231 \cdot \eta_v}$	[Gal/min]	1 Nm	8.851 in-lbs
<b>P</b>	Potenza <i>Power</i>	[kW] [HP]	$M = \frac{\Delta p \cdot V \cdot \eta_m}{62.83}$	[Nm]	1 Nm	0.7375 ft-lbs
<b>V</b>	Cilindrata <i>Displacement</i>	[cm <sup>3</sup> /giro] [in <sup>3</sup> /rev]	$M = \frac{\Delta p \cdot V \cdot \eta_m}{2 \cdot 3.14}$	[lbf.in]	1 N	0.2248 lbs
<b>n</b>	Velocità <i>Speed</i>	[min <sup>-1</sup> ]	$P = \frac{\Delta p \cdot V \cdot n \cdot \eta_t}{600 \cdot 1000}$	[kW]	1 kW	1.34 HP
<b>Δp</b>	Pressione <i>Pressure</i>	[bar] [PSI]	$P = \frac{\Delta p \cdot V \cdot n \cdot \eta_t}{395934}$	[HP]	1 cm <sup>3</sup> /giro	0.061 in <sup>3</sup> /rev
<b>η<sub>v</sub></b>	Rendimento volumetrico <i>Volumetric efficiency</i>				1 bar	14.5 PSI
<b>η<sub>m</sub></b>	Rendimento meccanico <i>Mechanical efficiency</i>				1 mm	0.0394 in
<b>η<sub>t</sub></b>	Rendimento totale <i>Overall efficiency</i>				1 kg	2.205 lbs

**MOTORI AD INGRANAGGI PRESTAZIONI**  
**GEAR MOTORS PERFORMANCES**

**GRUPPO GROUP 1SM**

DIAGRAMMA PORTATA - VELOCITÀ DI ROTAZIONE  
 FLOW - ROTATION SPEED CHART

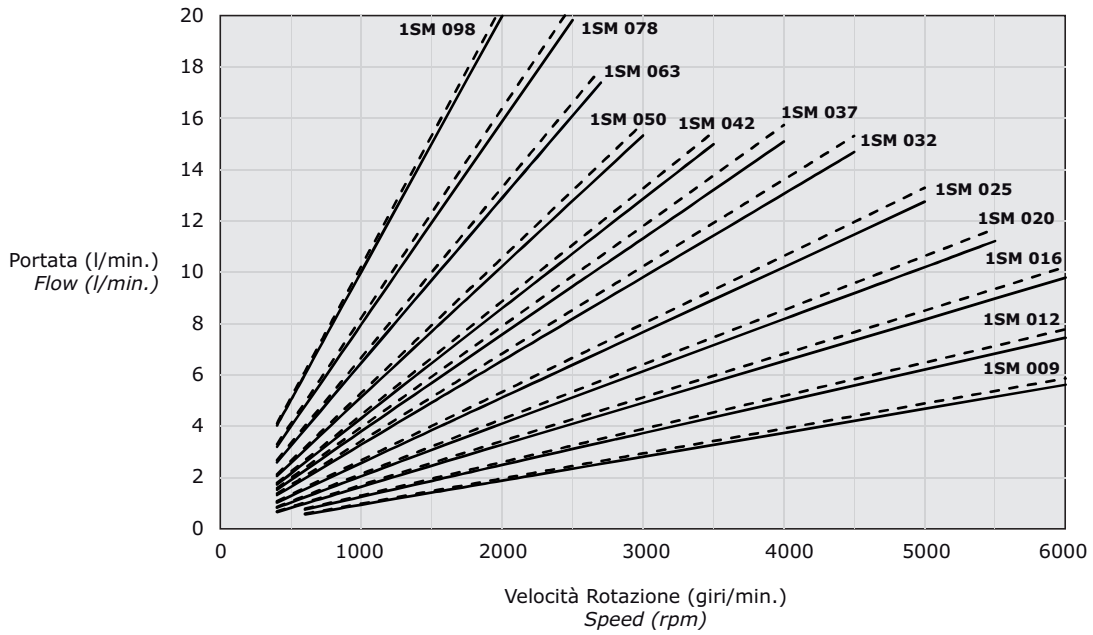

**GRUPPO GROUP 1SM**

DIAGRAMMI POTENZE  
 POWER DIAGRAM

Grafici rilevati a banco di collaudo a 40°C con olio VG46  
 Diagrams recorded on test bench at 40°C with VG46 mineral oil

**1SM 009**

**1SM 012**

**1SM 016**

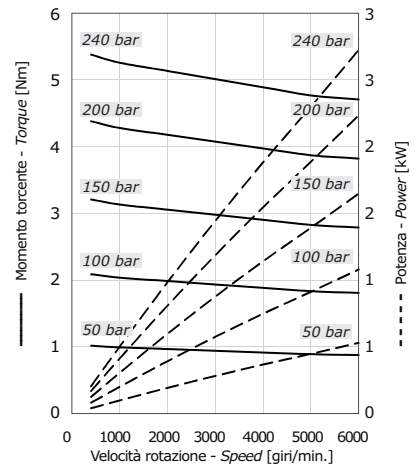
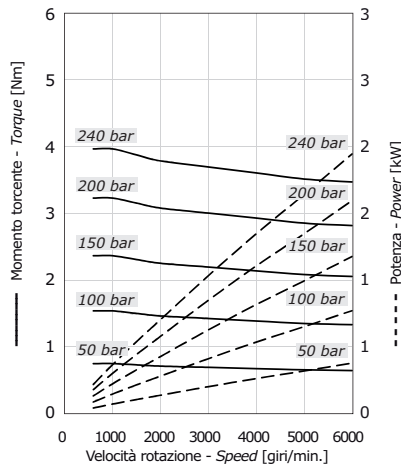
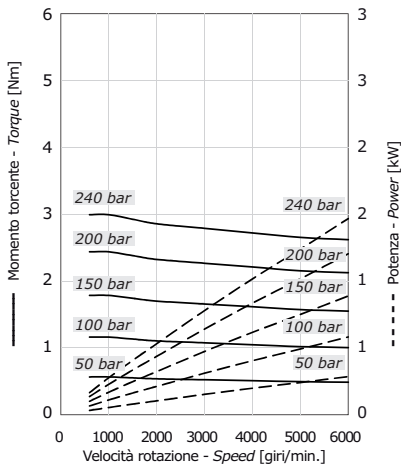

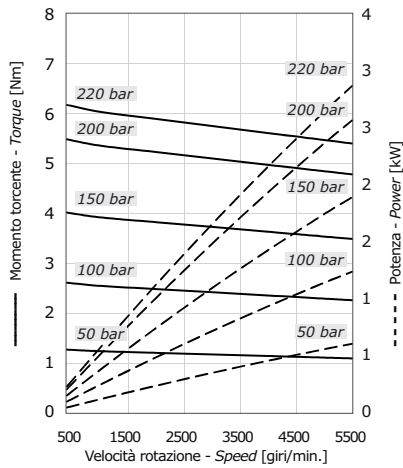
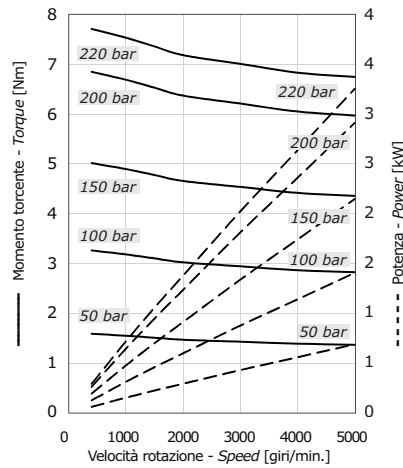
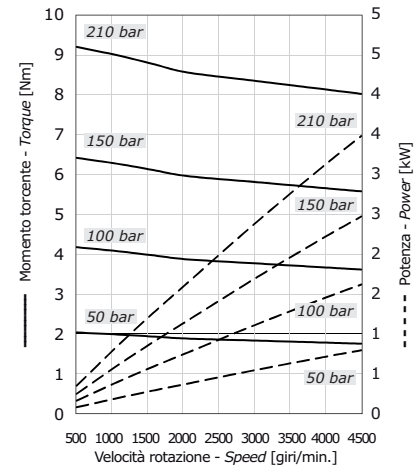
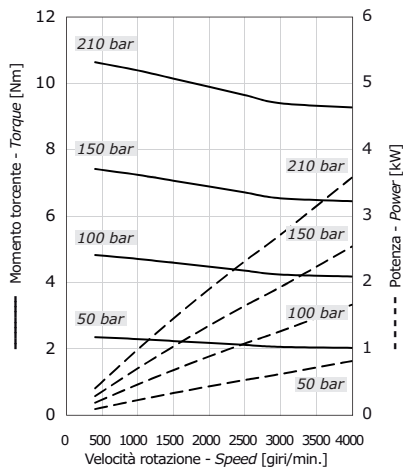
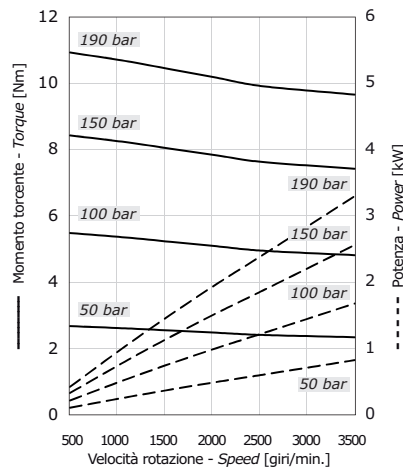
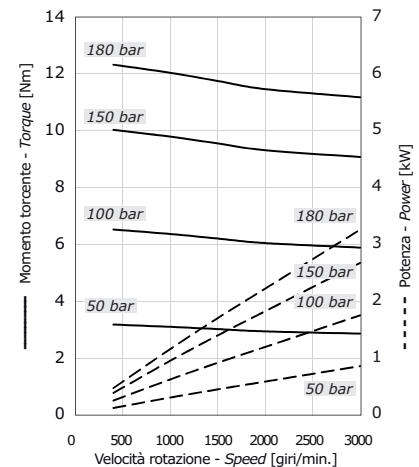
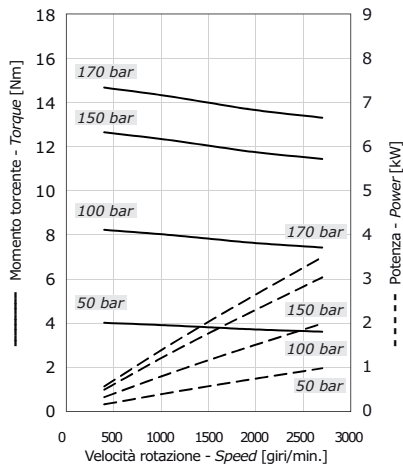
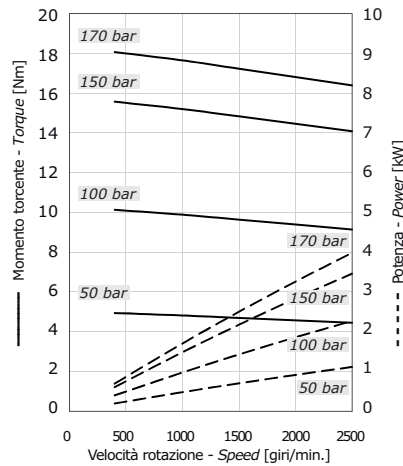
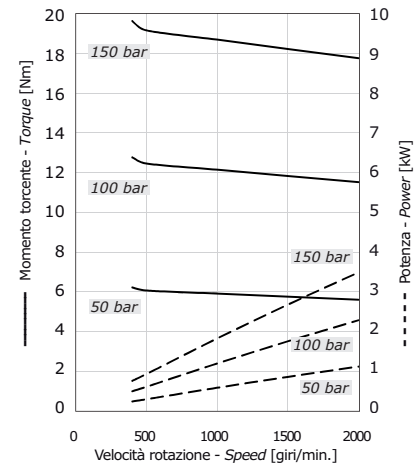
**MOTORI AD INGRANAGGI PRESTAZIONI**  
**GEAR MOTORS PERFORMANCES**
**1SM 020**

**1SM 025**

**1SM 032**

**1SM 037**

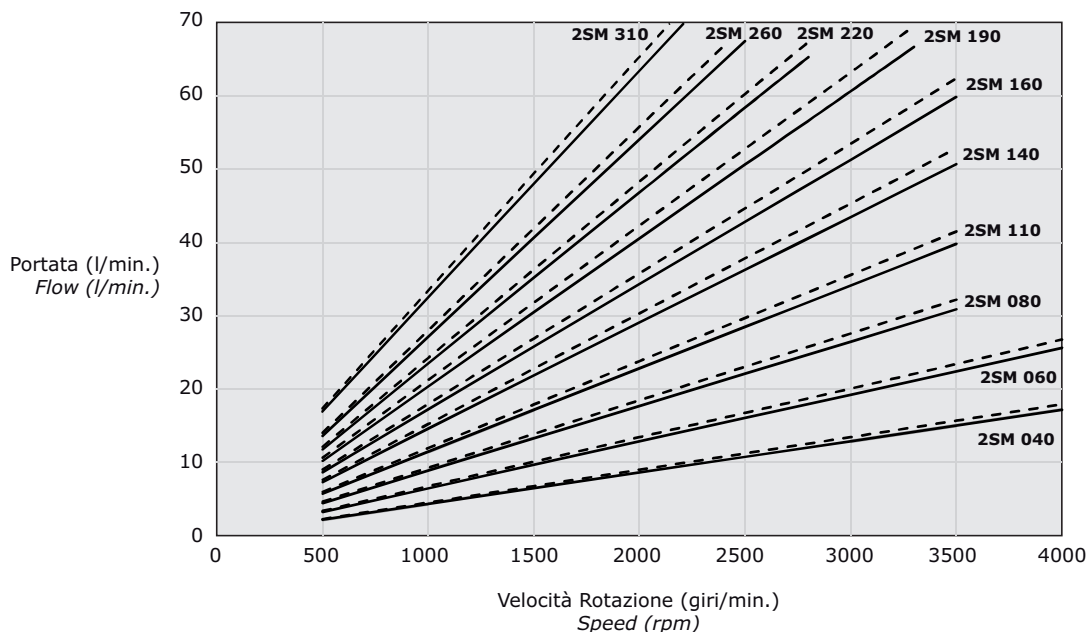
**1SM 042**

**1SM 050**

**1SM 063**

**1SM 078**

**1SM 098**

**MOTORI AD INGRANAGGI PRESTAZIONI**  
**GEAR MOTORS PERFORMANCES**

**GRUPPO GROUP 2SM**

DIAGRAMMA PORTATA - VELOCITÀ DI ROTAZIONE  
 FLOW - ROTATION SPEED CHART



**GRUPPO GROUP 2SM**

DIAGRAMMI POTENZE  
 POWER DIAGRAM

Grafici rilevati a banco di collaudo a 40°C con olio VG46  
 Diagrams recorded on test bench at 40°C with VG46 mineral oil

**2SM 040**

**2SM 060**

**2SM 080**

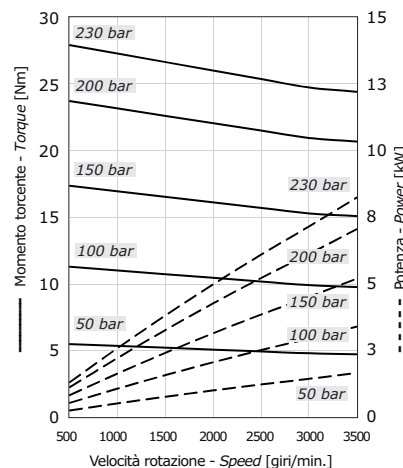
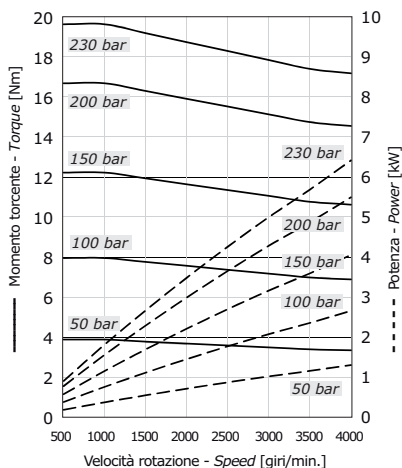
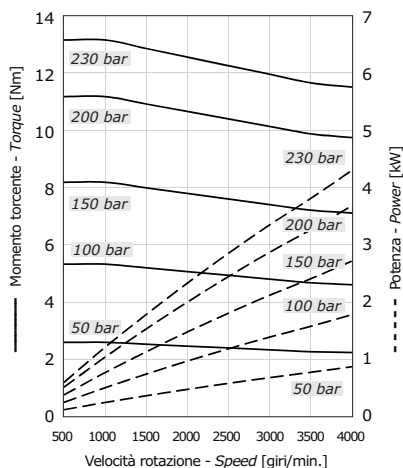

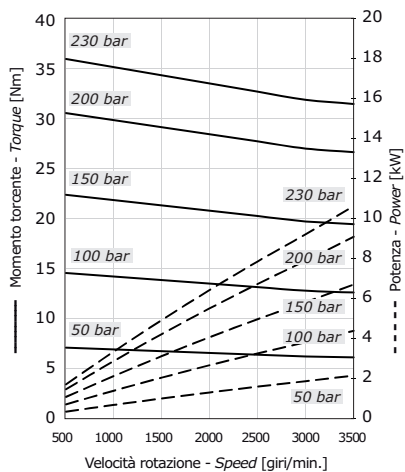
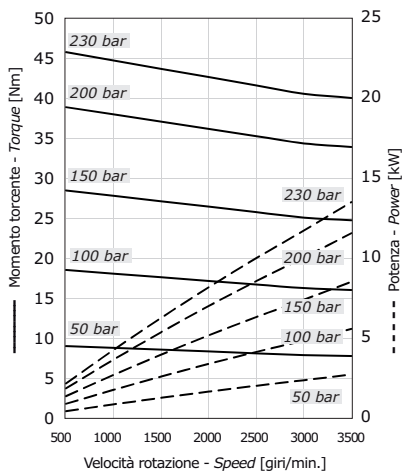
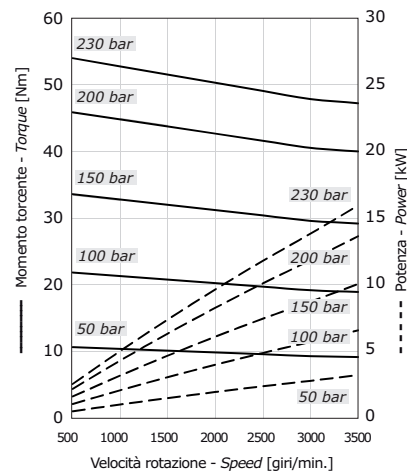
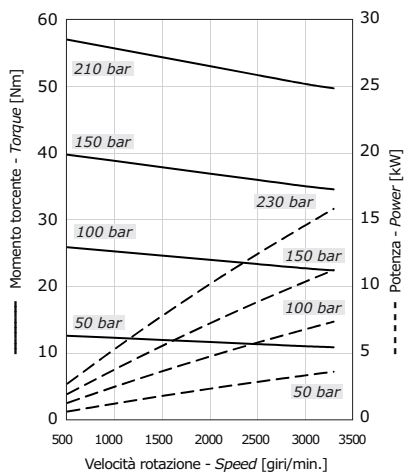
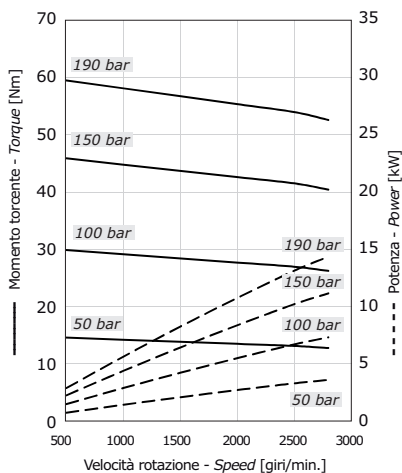
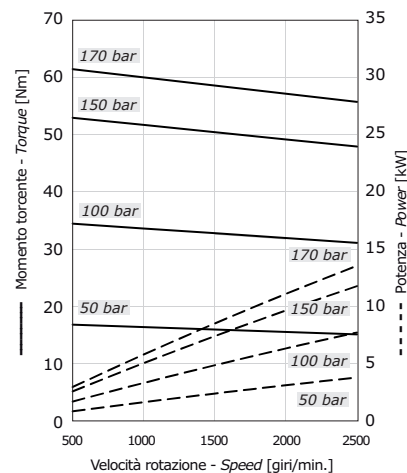
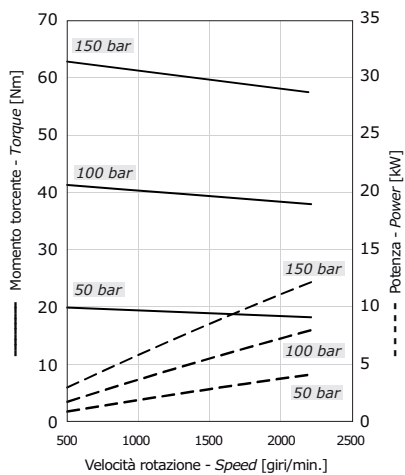
**MOTORI AD INGRANAGGI PRESTAZIONI**  
**GEAR MOTORS PERFORMANCES**
**2SM 110**

**2SM 140**

**2SM 160**

**2SM 190**

**2SM 220**

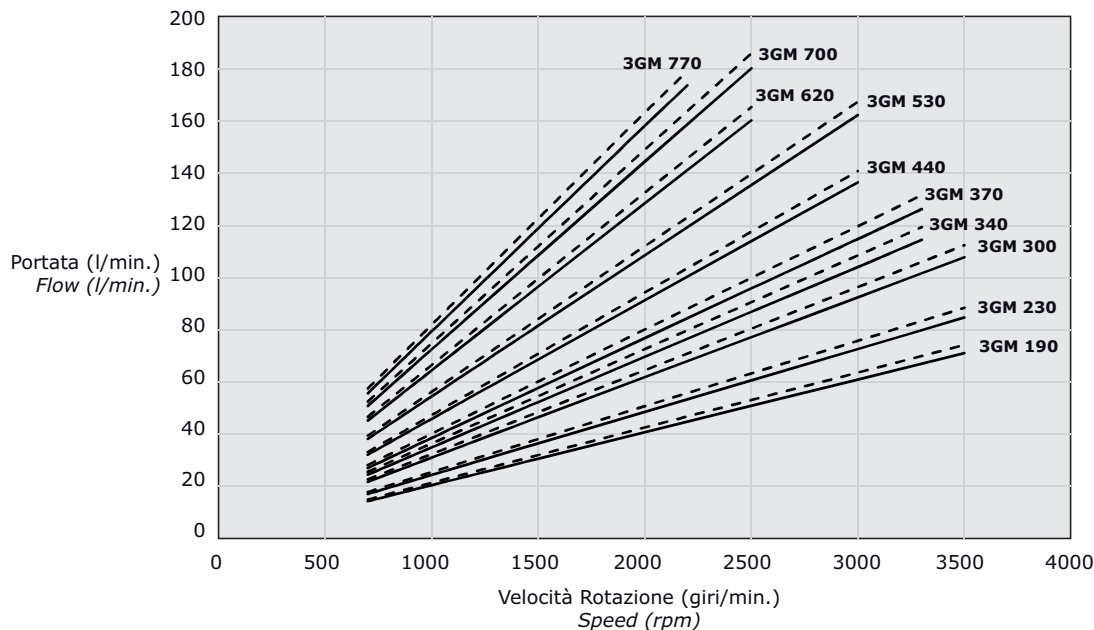
**2SM 260**

**2SM 310**



**MOTORI AD INGRANAGGI PRESTAZIONI**  
**GEAR MOTORS PERFORMANCES**

**GRUPPO GROUP 3GM**

DIAGRAMMA PORTATA - VELOCITÀ DI ROTAZIONE  
FLOW - ROTATION SPEED CHART



**GRUPPO GROUP 3GM**

DIAGRAMMI POTENZE  
POWER DIAGRAM

Grafici rilevati a banco di collaudo a 40°C con olio VG46  
Diagrams recorded on test bench at 40°C with VG46 mineral oil

**3GM 190**

**3GM 230**

**3GM 300**

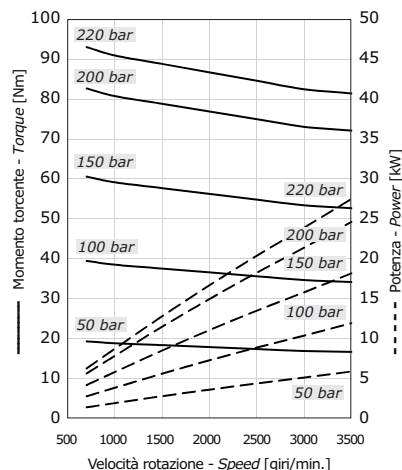
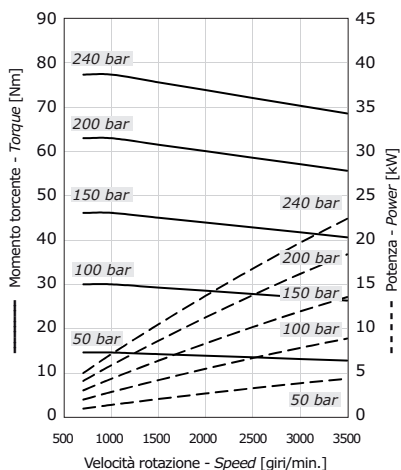
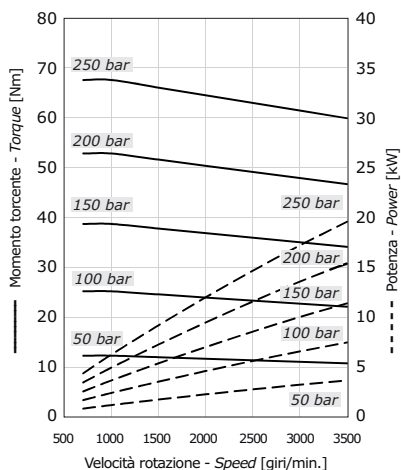

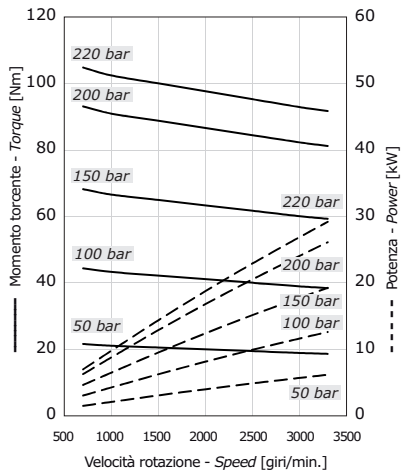
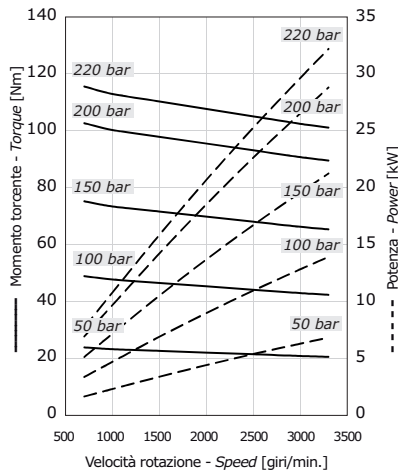
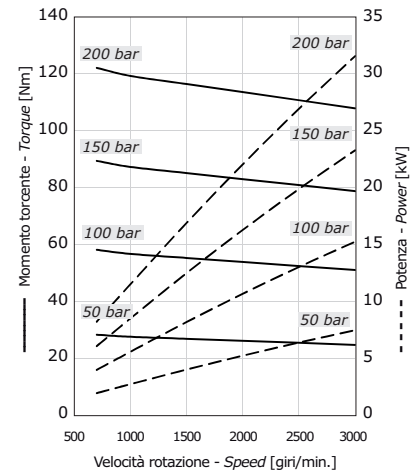
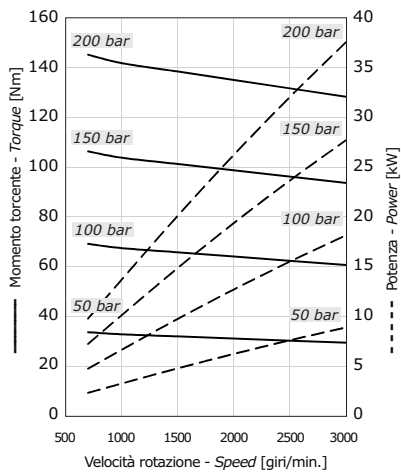
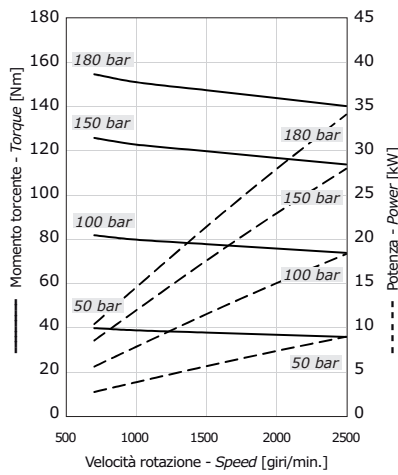
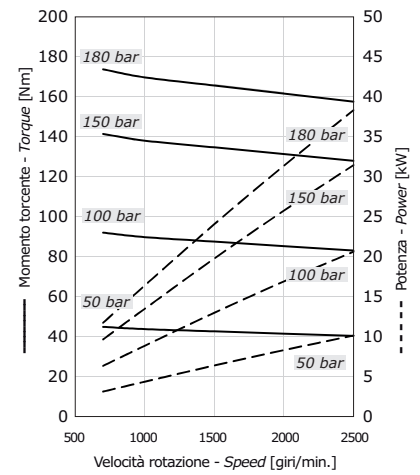
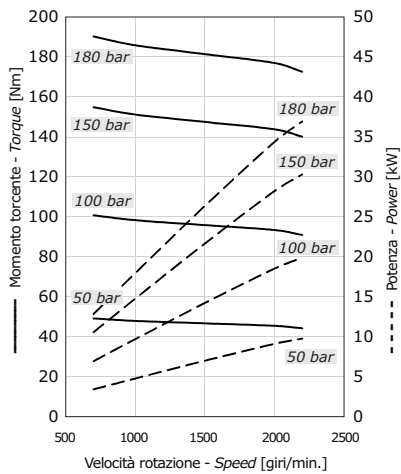
**MOTORI AD INGRANAGGI PRESTAZIONI**  
**GEAR MOTORS PERFORMANCES**
**3GM 340**

**3GM 370**

**3GM 440**

**3GM 530**

**3GM 620**

**3GM 700**

**3GM 770**

**MOTORI AD INGRANAGGI GRUPPO 1SM**  
**GEAR MOTORS GROUP 1SM**

**FLANGIA EUROPEA EUR EUROPEAN FLANGE**

GRUPPO GROUP 1SM	CILINDRATA DISPLACEMENT		PRESSIONE MAX MAX PRESSURE				VELOCITÀ MAX MAX SPEED	PORTATA MAX MAX FLOW		VELOCITÀ MIN MIN SPEED
	cm <sup>3</sup> /giro	in <sup>3</sup> /rev	P1		P2		giri/min - rpm	PORTATA MAX MAX FLOW		giri/min - rpm
			bar	psi	bar	psi		l/min	Gal/min	
<b>1SM 009*</b>	0.89	0.05	260	3770	280	4060	6000	5.3	1.40	600
<b>1SM 012*</b>	1.18	0.07	260	3770	280	4060	6000	7.1	1.88	600
<b>1SM 016*</b>	1.6	0.10	260	3770	280	4060	6000	9.6	2.54	400
<b>1SM 020*</b>	2.0	0.12	260	3770	280	4060	5500	11	2.91	400
<b>1SM 025*</b>	2.5	0.15	260	3770	280	4060	5000	12.5	3.30	400
<b>1SM 032*</b>	3.2	0.20	260	3770	280	4060	4500	14.4	3.80	400
<b>1SM 037</b>	3.7	0.23	250	3625	270	3915	4000	14.8	3.91	400
<b>1SM 042</b>	4.2	0.26	250	3625	270	3915	3500	14.7	3.88	400
<b>1SM 050</b>	5.0	0.31	250	3625	270	3915	3000	15	3.96	400
<b>1SM 063</b>	6.3	0.38	170	2465	190	2755	2700	17	4.49	400
<b>1SM 078</b>	7.76	0.47	170	2465	190	2755	2500	19.4	5.13	400
<b>1SM 098</b>	9.78	0.60	150	2175	170	2465	2000	19.6	5.18	400

\*Contattare il Servizio Commerciale per ordinare questi prodotti.  
Please contact our Sales Dpt to order these products.

Nota - Per valori di pressione superiori a quelli indicati contattare il Servizio Commerciale.  
Note - for higher pressure values please contact our Sales Dpt.

**DIMENSIONI • DIMENSIONS**

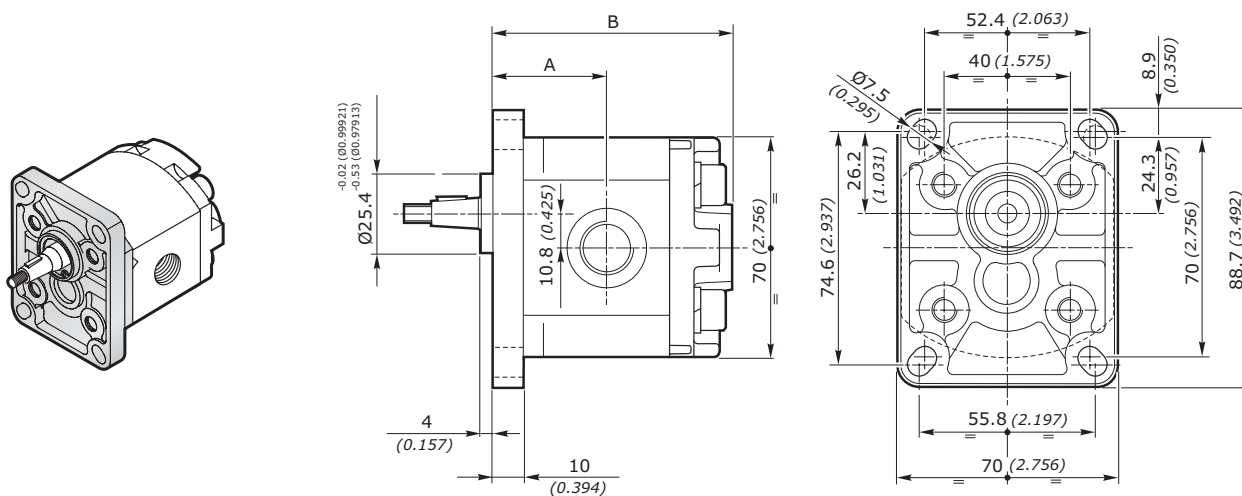

GRUPPO - GROUP 1	A		B		MASSA - MASS	
	mm	inch	mm	inch	kg	lbs
<b>1SM 009</b>	34.80	1.370	73.6	2.898	0.91	2.01
<b>1SM 012</b>	35.35	1.392	74.7	2.941	0.93	2.05
<b>1SM 016</b>	36.20	1.425	76.4	3.008	0.95	2.09
<b>1SM 020</b>	36.95	1.455	77.9	3.067	0.97	2.14
<b>1SM 025</b>	37.95	1.494	79.9	3.146	1.00	2.21
<b>1SM 032</b>	39.30	1.547	82.6	3.252	1.04	2.29
<b>1SM 037</b>	40.30	1.587	84.6	3.331	1.07	2.36
<b>1SM 042</b>	41.25	1.624	86.5	3.406	1.10	2.43
<b>1SM 050</b>	42.80	1.685	89.6	3.528	1.14	2.51
<b>1SM 063</b>	45.35	1.785	94.7	3.728	1.22	2.69
<b>1SM 078</b>	48.20	1.898	100.4	3.953	1.30	2.87
<b>1SM 098</b>	52.15	2.053	108.3	4.264	1.41	3.11

**MOTORI AD INGRANAGGI GRUPPO 1SM**  
**GEAR MOTORS GROUP 1SM**
**FLANGIA SAE** **SAEAA** **SAE FLANGE**

 \*Contattare il Servizio Commerciale per ordinare questi prodotti.  
 Please contact our Sales Dpt to order these products.

GRUPPO GROUP 1SM	CILINDRATA DISPLACEMENT		PRESSIONE MAX MAX PRESSURE				VELOCITÀ MAX MAX SPEED	PORTATA MAX MAX FLOW		VELOCITÀ MIN MIN SPEED
	cm <sup>3</sup> /giro	in <sup>3</sup> /rev	P1		P2		giri/min - rpm	PORTATA MAX MAX FLOW		giri/min - rpm
			bar	psi	bar	psi		l/min	Gal/min	
<b>1SM 009*</b>	0.89	0.05	260	3770	280	4060	6000	5.3	1.40	600
<b>1SM 012*</b>	1.18	0.07	260	3770	280	4060	6000	7.1	1.88	600
<b>1SM 016*</b>	1.6	0.10	260	3770	280	4060	6000	9.6	2.54	400
<b>1SM 020*</b>	2.0	0.12	260	3770	280	4060	5500	11	2.91	400
<b>1SM 025*</b>	2.5	0.15	260	3770	280	4060	5000	12.5	3.30	400
<b>1SM 032*</b>	3.2	0.20	260	3770	280	4060	4500	14.4	3.80	400
<b>1SM 037</b>	3.7	0.23	250	3625	270	3915	4000	14.8	3.91	400
<b>1SM 042</b>	4.2	0.26	250	3625	270	3915	3500	14.7	3.88	400
<b>1SM 050</b>	5.0	0.31	250	3625	270	3915	3000	15	3.96	400
<b>1SM 063</b>	6.3	0.38	170	2465	190	2755	2700	17	4.49	400
<b>1SM 078</b>	7.76	0.47	170	2465	190	2755	2500	19.4	5.13	400
<b>1SM 098</b>	9.78	0.60	150	2175	170	2465	2000	19.6	5.18	400

 Nota - Per valori di pressione superiori a quelli indicati contattare  
 il Servizio Commerciale.  
 Note - for higher pressure values please contact our Sales Dpt.

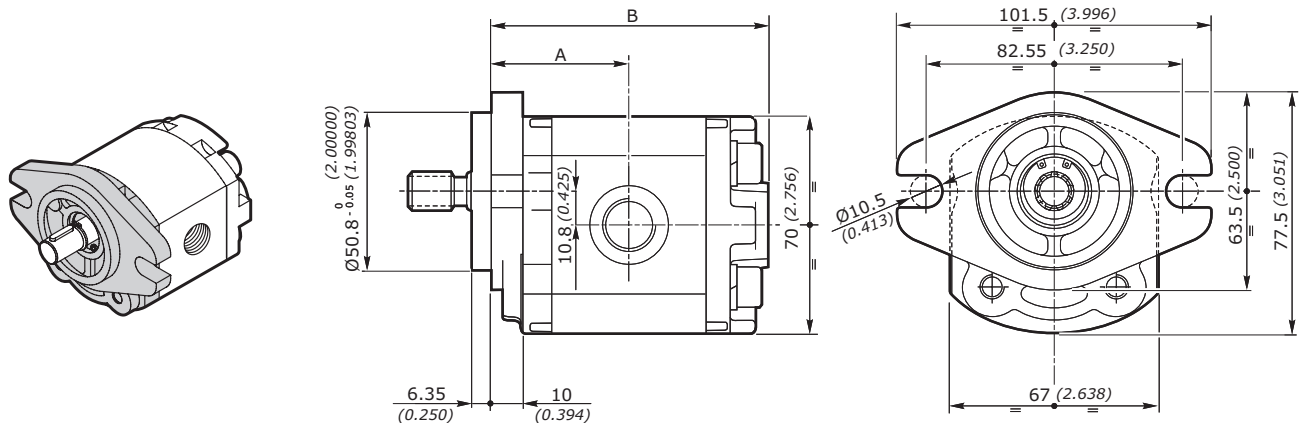
**DIMENSIONI • DIMENSIONS**

GRUPPO - GROUP 1	A		B		MASSA - MASS	
	mm	inch	mm	inch	kg	lbs
<b>1SP 009</b>	38.30	1.508	77.10	3.035	0.91	2.01
<b>1SP 012</b>	38.85	1.530	78.20	3.079	0.93	2.05
<b>1SP 016</b>	39.70	1.563	79.90	3.146	0.95	2.09
<b>1SP 020</b>	40.45	1.593	81.40	3.205	0.97	2.14
<b>1SP 025</b>	41.45	1.632	83.40	3.283	1.00	2.21
<b>1SP 032</b>	42.80	1.685	86.10	3.390	1.04	2.29
<b>1SP 037</b>	43.80	1.724	88.10	3.469	1.07	2.36
<b>1SP 042</b>	44.75	1.762	90.00	3.543	1.10	2.43
<b>1SP 050</b>	46.30	1.823	93.10	3.665	1.14	2.51
<b>1SP 063</b>	48.85	1.923	98.20	3.866	1.22	2.69
<b>1SP 078</b>	51.70	2.035	103.90	4.091	1.30	2.87
<b>1SP 098</b>	55.65	2.191	111.80	4.402	1.41	3.11

**MOTORI AD INGRANAGGI GRUPPO 1SM**  
**GEAR MOTORS GROUP 1SM**
**CODICE ORDINAZIONE • ORDER CODE**
**1SM - A - 020 - D - EUR - H - N - 10 - 0 - G**

SIGLA - CODE	TIPO - TYPE	DESCRIZIONE - DESCRIPTION	PAGINA - PAGE
<b>1SM</b>	Tipo motore <i>Motor type</i>	Motore - gruppo 1 <i>Motor - group 1</i>	100
<b>A</b>	Materiale flangia e coperchio <i>Flange and cover material</i>	<b>A</b> = alluminio / <i>aluminium</i>	116
<b>020</b>	Cilindrata <i>Displacement</i>	Cilindrata = 2 cm <sup>3</sup> /g <i>Displacement = 0.12 in<sup>3</sup>/rev</i>	100
<b>D</b>	Senso di rotazione <i>Rotation wise</i>	<b>D</b> = Rotazione destra / <i>Clockwise rotation</i> <b>S</b> = Rotazione sinistra / <i>Anticlockwise rotation</i> <b>R</b> = Reversibile / <i>Reversible</i>	104
<b>EUR</b>	Tipo Flangia <i>Flange type</i>	Flangia europea standard <i>Standard European flange</i>	116
<b>H</b>	Tipo anello di tenuta <i>Seal ring type</i>	Vedi tabella compatibilità <i>See compatibility table</i>	
<b>N</b>	Tipo guarnizione <i>Gasket type</i>	<b>N</b> = NBR <b>V</b> = Viton	117
<b>10</b>	Tipo Albero <i>Shaft type</i>	Vedi tabella compatibilità <i>See compatibility table</i>	
<b>0</b>	Posizione connessione <i>Connection position</i>	Vedi tabella compatibilità <i>See compatibility table</i>	119
<b>G</b>	Tipo connessione <i>Connection type</i>	Vedi tabella compatibilità <i>See compatibility table</i>	120



**MOTORI AD INGRANAGGI GRUPPO 1SM**  
**GEAR MOTORS GROUP 1SM**
**TIPOLOGIA FLANGIA • FLANGE TYPE**

	EUR	SAEAA
<b>1SM</b>		
<b>A</b> alluminio-aluminium	◇	◇
<b>G</b> ghisa-cast iron	non disponibile not available	non disponibile not available

◇ = Combinazione standard - Standard combination

**ANELLO DI TENUTA • SEAL RING**

SIGLA - CODE	TIPO - TYPE	DIAGRAMMA - DIAGRAM
--------------	-------------	---------------------

**A** Flangia senza anello di tenuta  
 Flange without seal ring

/

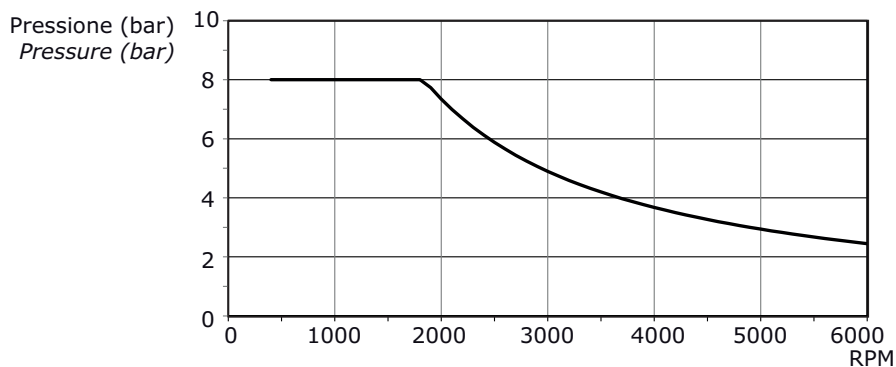
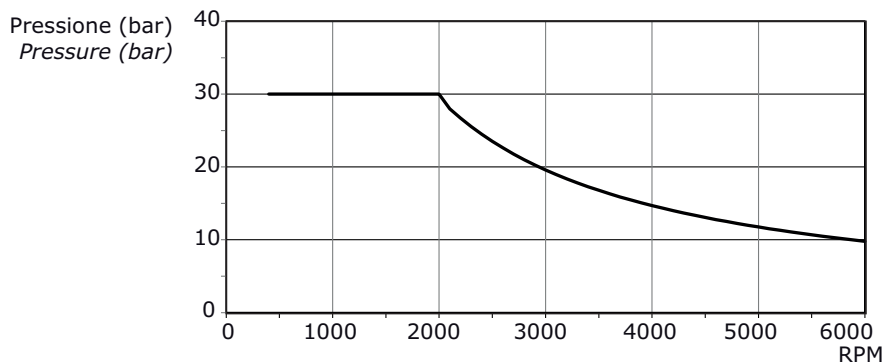
**H** Anello di tenuta fino a **8** bar  
 Sealing ring up to **8** bar

**K** Anello di tenuta fino a **30** bar  
 Sealing ring up to **30** bar

**MOTORI AD INGRANAGGI GRUPPO 1SM**  
**GEAR MOTORS GROUP 1SM**

**COMBINAZIONE FLANGIA - ANELLO DI TENUTA - GUARNIZIONE • FLANGE - SEAL RING - GASKET COMBINATION**

1SM		EUR			SAEAA		
		H	K	W	H	K	W
NBR	<b>N</b>	◆	◆	◆	◆	◆	◆
Viton	<b>V</b>	●	●	●	●	●	●

esempio • example: **1SM - A - 020 - D - EUR - H - N - 10 - 0 - G**

**EUR** = Flangia europea / *European flange*

**H** = Anello tenuta fino a 8 bar / *Seal ring up to 8 bar*

**N** = Guarnizione in NBR / *NBR o-ring*

**COMBINAZIONE ALBERO - FLANGIA • SHAFT - FLANGE COMBINATION**

1SM		EUR		SAEAA	
		<b>10</b> Conico 1:8 <i>Tapered 1:8</i>	◆	●	
<b>11</b> Conico 1:5 <i>Tapered 1:5</i>	●	●			
<b>13</b> Cilindrico SAEAA <i>Parallel shaft SAEAA</i>	●		◆		
<b>14</b> Scanalato SAEAA 9 denti <i>SAEAA 9T splined</i>	●		◆		
<b>15</b> Scanalato DIN5480 6T 12x9 <i>DIN5480 Splined</i>	●		●		
<b>17</b> Fresato a dente frontale <i>Dihedral claw</i>					
<b>27</b> Fresato a dente frontale (con anello) <i>Dihedral claw (with sealing ring)</i>	●	●			

◆ = Combinazione standard - *Standard combination*

● = Combinazione disponibile - *Available combination*

**MOTORI AD INGRANAGGI GRUPPO 1SM**  
**GEAR MOTORS GROUP 1SM**
**1SM**

## DIMENSIONI ALBERO - SHAFT DIMENSIONS

<p><b>10</b> Conico 1:8 Tapered 1:8</p> <p>Coppia 30 Nm Torque 22 ft-lbs</p>	<p>Disponibile per - available for: <b>EUR - MC32</b></p>	<p>Disponibile per - available for: <b>SAEAA</b></p>
<p><b>11</b> Conico 1:5 Tapered 1:5</p> <p>Coppia 30 Nm Torque 22 ft-lbs</p>	<p>Disponibile per - available for: <b>EUR - MC32</b></p>	<p>Disponibile per - available for: <b>SAEAA</b></p>
<p><b>13</b> Cilindrico SAEAA Parallel shaft SAEAA</p> <p>Coppia 35 Nm Torque 26 ft-lbs</p>	<p>Disponibile per - available for: <b>EUR</b></p>	<p>Disponibile per - available for: <b>SAEAA</b></p>
<p><b>14</b> Scanalato SAEAA 9 denti SAEAA 9T splined</p> <p>Coppia 40 Nm Torque 30 ft-lbs</p>	<p>Disponibile per - available for: <b>EUR</b></p>	<p>Disponibile per - available for: <b>SAEAA</b></p>
<p><b>15</b> Scanalato DIN 5480 6T 12x9 DIN 5480 splined</p> <p>Coppia 30 Nm Torque 22 ft-lbs</p>	<p>Disponibile per - available for: <b>EUR - MC32</b></p>	<p>Disponibile per - available for: <b>SAEAA</b></p>



**MOTORI AD INGRANAGGI GRUPPO 1SM**  
**GEAR MOTORS GROUP 1SM**

**1SM**

DIMENSIONI ALBERO - SHAFT DIMENSIONS

**17**  
Fresato  
a dente frontale  
*Dihedral claw*

Coppia 25 Nm  
Torque 19 ft-lbs

Giunto incluso - Coupling included  
Codice - Code: **010453088499**

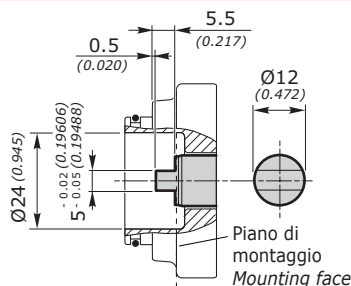
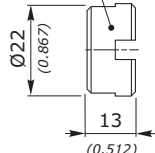

Disponibile per - available for: **E32BX - E32BC - E32CX - E32CC**

**27**  
Fresato  
a dente frontale  
(con anello)  
*Dihedral claw  
(with sealing ring)*

Coppia 25 Nm  
Torque 19 ft-lbs

Giunto non incluso  
Coupling not included  
Codice - Code:  
**010453088499**

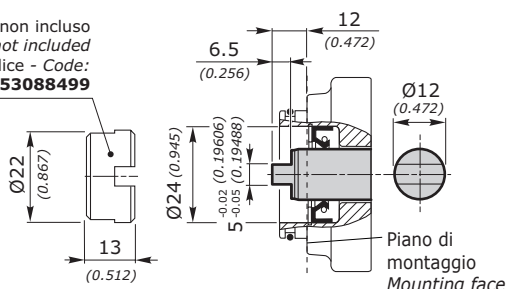

Disponibile per - available for: **EUR - MC32**

Giunto non incluso  
Coupling not included  
Codice - Code:  
**010453088499**

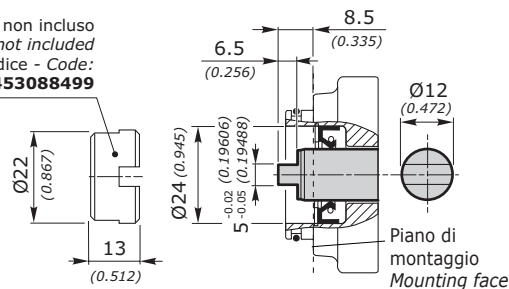

Disponibile per - available for: **SAEAA**

**POSIZIONE CONNESSIONE • CONNECTION POSITION**



Rotazione destra - **D**  
Right rotation - **D**

Rotazione sinistra - **S**  
Left rotation - **S**

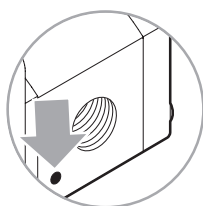
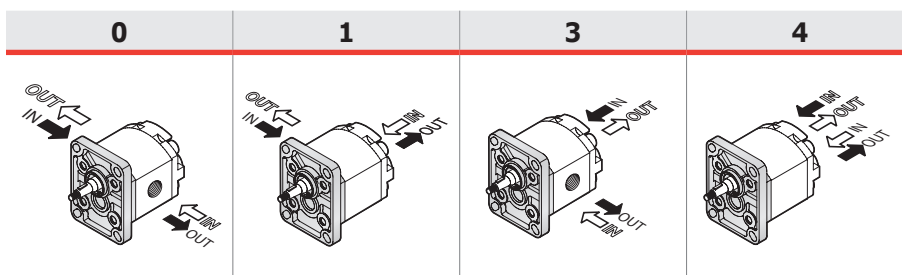

Il segno del corpo indica il LATO SCARICO per i motori  
The sign on the body identifies the OUTLET SIDE for the motors

**IN = INGRESSO - INLET**  
**OUT = SCARICO - OUTLET**

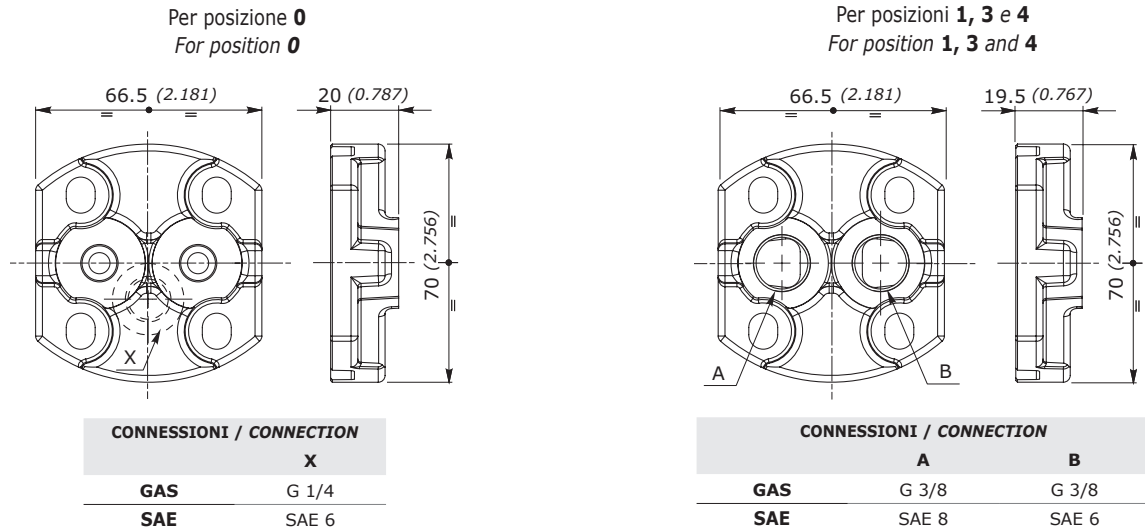
**MOTORI AD INGRANAGGI GRUPPO 1SM**  
**GEAR MOTORS GROUP 1SM**
**COPERCHIO STANDARD • STANDARD COVER**

NOTA - (X) Coperchio standard disponibile con drenaggio G 1/4 e SAE 6 contattare il Servizio Commerciale.

Note - (X) Available standard cover with drain G 1/4 and SAE 6. Please contact our Sales Dpt.

**TIPO CONNESSIONE • CONNECTION TYPE**

Le connessioni rappresentate corrispondono alle versioni standard; per connessioni differenti, contattare il nostro Ufficio Commerciale.

The connection types shown correspond to standard configurations; for different applications contact our Commercial Dept.

<b>1SM</b>		POSIZIONE CONNESSIONE - CONNECTION POSITION				
		<b>0</b>	<b>1</b>	<b>3</b>	<b>4</b>	<b>DRENAGGIO DRAIN</b>
GAS	<b>G</b>	◇	◇	◇	◇	◇
UNF	<b>U</b>	◇	◇	◇	◇	◇
FLANGIATE FLANGED	<b>T</b>	◇				
	<b>N</b>	◇				

<b>GAS</b>	UNI ISO 228/1	SIGLA CODE	CIL. DISPL.	SCARICO - OUTLET OUT			INGRESSO - INLET IN		
				A	B		A	B	
	G		009	G 3/8"	14 [mm] 0.552 [inch]	40 [Nm] 354 [in.lbs]	G 3/8"	14 [mm] 0.552 [inch]	40 [Nm] 354 [in.lbs]
			012						
			016						
			020						
			025						
			032						
			037						
			042						
			050						
			063						
			078						
			098						

**MOTORI AD INGRANAGGI GRUPPO 1SM**  
**GEAR MOTORS GROUP 1SM**

UNF	ANSI/ASME B1.1	SIGLA CODE	CIL. DISPL.	SCARICO - OUTLET OUT			INGRESSO - INLET IN			
				A	B		A	B		
	U	009								
		012	SAE 6 9/16"-18 UNF	13 [mm] 0.512 [inch]	40 [Nm] 354 [in.lbs]	SAE 6 9/16"-18 UNF	13 [mm] 0.512 [inch]	40 [Nm] 354 [in.lbs]		
		016								
		020								
		025								
		032	SAE 8 3/4"-14 UNF	15 [mm] 0.591 [inch]	50 [Nm] 443 [in.lbs]	SAE 8 3/4"-14 UNF	15 [mm] 0.591 [inch]	50 [Nm] 443 [in.lbs]		
		037								
		042								
		050								
		063								
		078								
		098								

FLANGIATE FLANGED	ISO/R 262	SIGLA CODE	CIL. DISPL.	SCARICO - OUTLET OUT					INGRESSO - INLET IN				
				A	B	C	D		A	B	C	D	
	T	009											
		012	12 [mm] 0.472 [inch]	30 [mm] 1.181 [inch]	M6	13 [mm] 0.512 [inch]	8 [Nm] 71 [in.lbs]	12 [mm] 0.472 [inch]	30 [mm] 1.181 [inch]	M6	13 [mm] 0.512 [inch]	8 [Nm] 71 [in.lbs]	
		016											
		020											
		025											
		032	13 [mm] 0.512 [inch]	30 [mm] 1.181 [inch]	M6	11 [mm] 0.433 [inch]	8 [Nm] 71 [in.lbs]	13 [mm] 0.512 [inch]	30 [mm] 1.181 [inch]	M6	11 [mm] 0.433 [inch]	8 [Nm] 71 [in.lbs]	
		037											
		042											
		050											
		063											
078													
098													

**MOTORI AD INGRANAGGI GRUPPO 1SM**  
**GEAR MOTORS GROUP 1SM**
**OPZIONI • OPTIONS**
**VLPI**

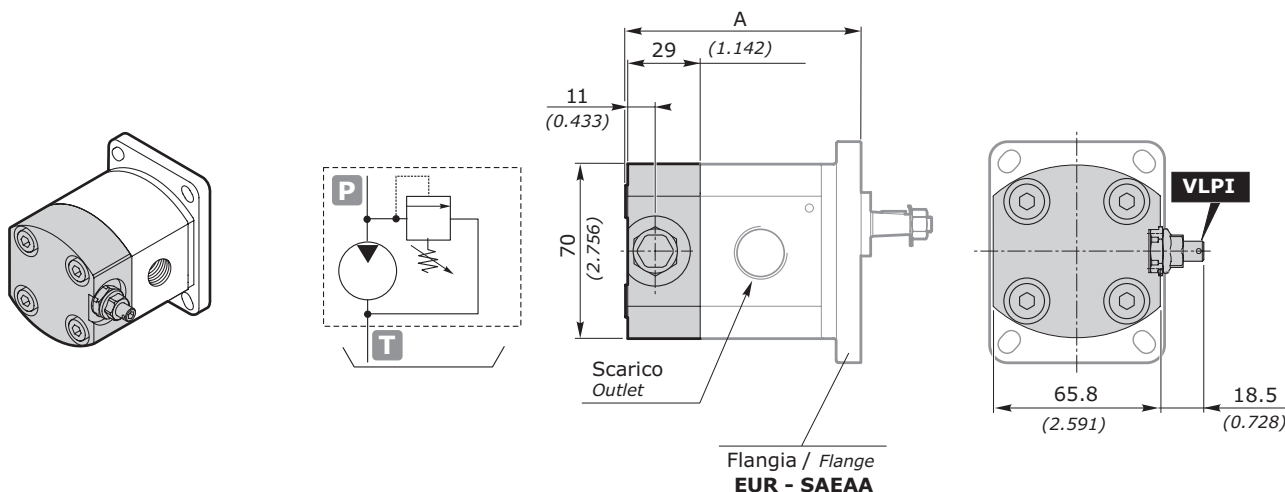
 VALVOLA LIMITATRICE DI PRESSIONE A SCARICO INTERNO  
 PRESSURE RELIEF VALVE WITH INTERNAL EXHAUST

GRUPPO GROUP 1	A EUR		A SAEAA	
	mm	inch	mm	inch
1SM 009	82.6	3.252	86.1	3.390
1SM 012	83.7	3.295	87.2	3.433
1SM 016	85.4	3.362	88.9	3.500
1SM 020	86.9	3.421	90.4	3.559
1SM 025	88.9	3.500	92.4	3.638
1SM 032	91.6	3.606	95.1	3.744
1SM 037	93.6	3.685	97.1	3.823
1SM 042	95.5	3.760	99.0	3.898
1SM 050	98.6	3.882	102.1	4.020
1SM 063	103.7	4.083	107.2	4.220
1SM 078	109.4	4.307	112.9	4.445
1SM 098	117.3	4.618	120.8	4.756

**ATTENZIONE:**

La valvola limitatrice di pressione si applica sostituendo il coperchio posteriore (previsto solo scarico interno). Il coperchio VLP è disponibile in alluminio.

**WARNING:**

The pressure relief valve can be applied by replacing the rear cover (only internal relief is set). VLP cover is available in aluminum.

 esempio • example: **1SM - A - 020 - D - EUR - H - N - 10 - 0 - G - VLPI (N 120)**
**VLPI** = Coperchio con VPL a scarico interno / Cover with VPL with internal exhaust

**N** = Tipo molla - vedi tabella / Spring type - see table

**120** = Taratura - vedi tabella / Setting - see table

TIPO - TYPE	CAMPI DI TARATURE - CALIBRATION FIELDS					
	molla bianca - white spring	B	molla nera - black spring	N	molla rossa - red spring	R
bar	30 ÷ 80		81 ÷ 200		201 ÷ 350	
psi	435 ÷ 1160		1175 ÷ 2900		2915 ÷ 5075	
STANDARD	70 bar (1015 psi)		150 bar (2175 psi)		250 bar (3625 psi)	

NOTA: In caso di omissione del valore di taratura, esso sarà inteso standard (vedi tabella).

NOTE: Without setting request, it will be considered standard (see table).

**MOTORI AD INGRANAGGI GRUPPO 1SM**  
**GEAR MOTORS GROUP 1SM**

**VLPE**

VALVOLA LIMITATRICE DI PRESSIONE A SCARICO ESTERNO  
PRESSURE RELIEF VALVE WITH EXTERNAL EXHAUST

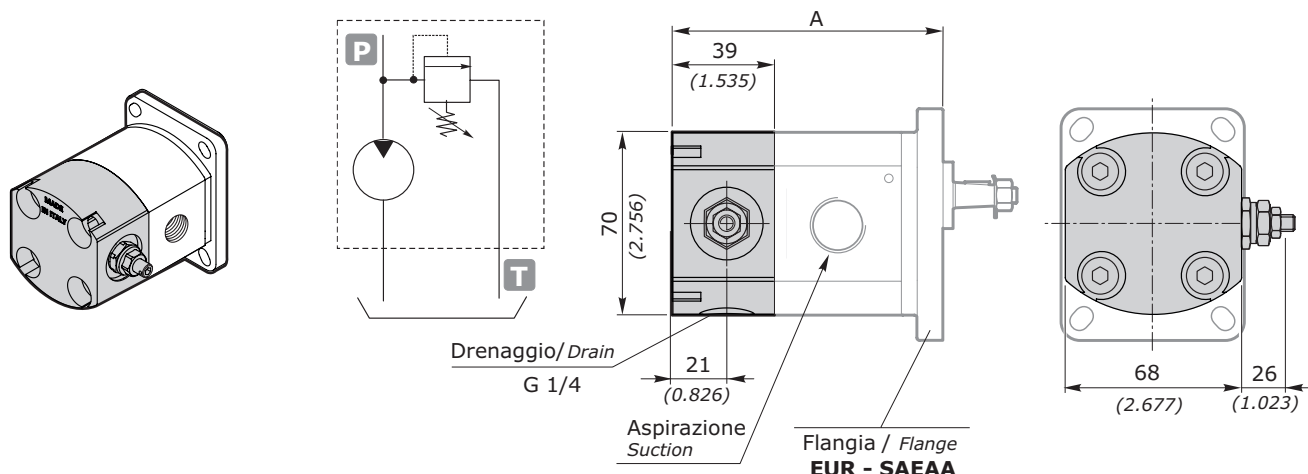

GRUPPO GROUP 1	A EUR		A SAEAA	
	mm	inch	mm	inch
1SP 009	92.6	3.645	96.1	3.783
1SP 012	93.7	3.688	97.2	3.826
1SP 016	95.4	3.755	98.9	3.893
1SP 020	96.9	3.814	100.4	3.952
1SP 025	98.9	3.893	102.4	4.031
1SP 032	101.6	4	105.1	4.137
1SP 037	103.6	4.078	107.1	4.216
1SP 042	105.5	4.153	109.0	4.291
1SP 050	108.6	4.275	112.1	4.413
1SP 063	113.7	4.476	117.2	4.614
1SP 078	119.4	4.7	122.9	4.838
1SP 098	127.3	5.011	130.8	5.149

La valvola limitatrice di pressione si applica sostituendo il coperchio posteriore. Il coperchio VLP è disponibile in alluminio. E' rappresentato un motore con rotazione sinistra. Nei motori con rotazione destra, la valvola è dal lato opposto.

*The pressure relief valve can be applied by substituting the rear cover. VLP cover is available in aluminum. The showed motor is with anticlockwise rotation. In the case of motor with clockwise rotation, the valve is on the opposite side.*

esempio • example: **1SM - A - 020 - D - EUR - H - N - 10 - 0 - G - VLPE (N 120)**

**VLPE** = Coperchio con VPL a scarico esterno / Cover with VPL with external exhaust

**N** = Tipo molla - vedi tabella / Spring type - see table

**120** = Taratura - vedi tabella / Setting - see table

TIPO - TYPE	CAMPI DI TARATURE - CALIBRATION FIELDS					
	molla bianca - white spring	<b>B</b>	molla nera - black spring	<b>N</b>	molla rossa - red spring	<b>R</b>
bar	30 ÷ 80		81 ÷ 200		201 ÷ 350	
psi	435 ÷ 1160		1175 ÷ 2900		2915 ÷ 5075	
STANDARD	70 bar (1015 psi)		150 bar (2175 psi)		250 bar (3625 psi)	

NOTA: In caso di omissione del valore di taratura, esso sarà inteso standard (vedi tabella).

NOTE: Without setting request, it will be considered standard (see table).

**MOTORI AD INGRANAGGI GRUPPO 2SM**  
**GEAR MOTORS GROUP 2SM**
**FLANGIA EUROPEA EUR EUROPEAN FLANGE**
**FLANGIA E COPERCHIO IN ALLUMINIO - FLANGE AND COVER IN ALUMINIUM**

GRUPPO GROUP 2SM	CILINDRATA DISPLACEMENT		PRESSIONE MAX - MAX PRESSURE								VELOCITÀ MAX MAX SPEED	PORTATA MAX MAX FLOW		VELOCITÀ MIN MIN SPEED
			S - D		R		S - D		R					
	cm <sup>3</sup> /giro	in <sup>3</sup> /rev	P1 bar	P1 psi	P1 bar	P1 psi	P2 bar	P2 psi	P2 bar	P2 psi	giri/min - rpm	l/min	Gal/min	giri/min - rpm
<b>2SM 040</b>	4	0.24	250	3625	210	3045	270	3915	230	3335	4000	16	4.23	500
<b>2SM 060</b>	6	0.37	250	3625	210	3045	270	3915	230	3335	4000	24	6.34	500
<b>2SM 080</b>	8.5	0.52	250	3625	210	3045	270	3915	230	3335	3500	29.7	7.85	500
<b>2SM 110</b>	11	0.67	250	3625	210	3045	270	3915	230	3335	3500	38.5	10.17	500
<b>2SM 140</b>	14	0.85	250	3625	210	3045	270	3915	230	3335	3500	49	12.95	500
<b>2SM 160</b>	16.5	1.01	230	3335	195	2827	240	3480	205	2972	3500	57.7	15.24	500
<b>2SM 190</b>	19.5	1.19	210	3045	180	2610	220	3190	190	2755	3300	64.3	16.99	500
<b>2SM 220</b>	22.5	1.37	190	2755	160	2320	200	2900	170	2465	2800	63	16.64	500
<b>2SM 260</b>	26	1.59	170	2465	145	2102	180	2610	155	2248	2500	65	17.17	500
<b>2SM 310</b>	31.5	1.92	130	1885	110	1595	140	2030	120	1740	2200	69	18.22	500

Nota - Per valori di pressione superiori a quelli indicati contattare il Servizio Commerciale.  
 Note - for higher pressure values please contact our Sales Dpt.

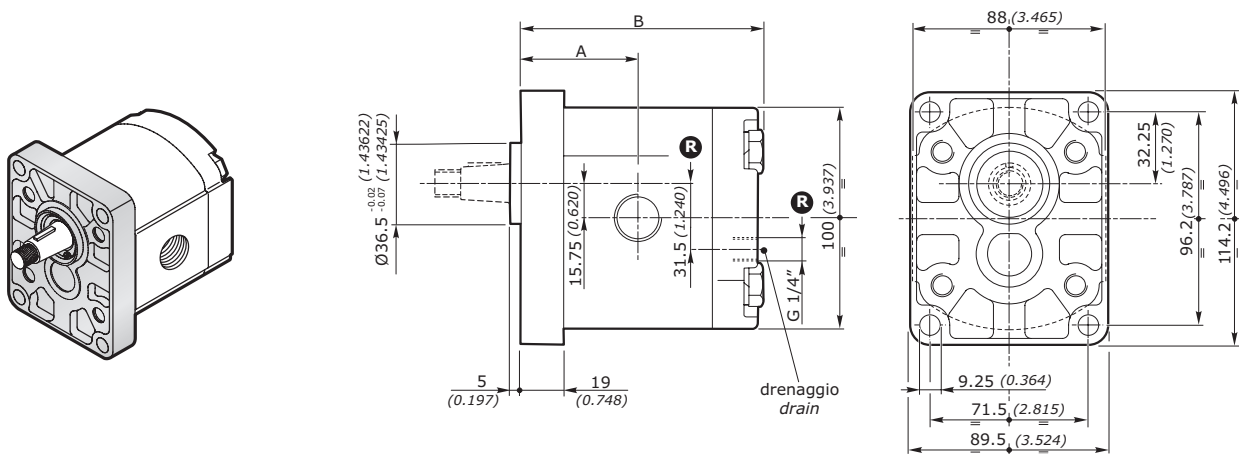
**DIMENSIONI • DIMENSIONS**

**R** Solo per motori reversibili - Only for reversible motors

GRUPPO - GROUP 2	A		B		MASSA - MASS	
	mm	inch	mm	inch	kg	lbs
<b>2SM 040</b>	44.4	1.748	93.0	3.661	2.30	5.07
<b>2SM 060</b>	46.0	1.811	96.3	3.791	2.45	5.40
<b>2SM 080</b>	48.1	1.894	100.5	3.957	2.60	5.73
<b>2SM 110</b>	50.2	1.976	104.6	4.118	2.70	5.95
<b>2SM 140</b>	52.7	2.075	109.6	4.315	2.80	6.17
<b>2SM 160</b>	54.8	2.157	113.8	4.480	2.95	6.51
<b>2SM 190</b>	57.3	2.256	118.8	4.677	3.10	6.84
<b>2SM 220</b>	59.8	2.354	123.8	4.874	3.25	7.17
<b>2SM 260</b>	62.7	2.469	129.6	5.102	3.40	7.50
<b>2SM 310</b>	66.9	2.636	138.0	5.437	3.61	7.96

**MOTORI AD INGRANAGGI GRUPPO 2SM**  
**GEAR MOTORS GROUP 2SM**

**FLANGIA EUROPEA EUR EUROPEAN FLANGE**

**FLANGIA E COPERCHIO IN GHISA - FLANGE AND COVER IN CAST IRON**

GRUPPO GROUP 2SM	CILINDRATA DISPLACEMENT		PRESSIONE MAX - MAX PRESSURE								VELOCITÀ MAX MAX SPEED	PORTATA MAX MAX FLOW		VELOCITÀ MIN MIN SPEED
			S - D		R		S - D		R					
	cm³/giro	in³/rev	P1 bar	P1 psi	P1 bar	P1 psi	P2 bar	P2 psi	P2 bar	P2 psi	giri/min - rpm	l/min	Gal/min	giri/min - rpm
<b>2SM 040</b>	4	0.24	260	3770	220	3190	280	4060	240	3480	4000	16	4.23	500
<b>2SM 060</b>	6	0.37	260	3770	220	3190	280	4060	240	3480	4000	24	6.34	500
<b>2SM 080</b>	8.5	0.52	260	3770	220	3190	280	4060	240	3480	3500	29.7	7.85	500
<b>2SM 110</b>	11	0.67	260	3770	220	3190	280	4060	240	3480	3500	38.5	10.17	500
<b>2SM 140</b>	14	0.85	260	3770	220	3190	280	4060	240	3480	3500	49	12.95	500
<b>2SM 160</b>	16.5	1.01	240	3480	205	2972	250	3625	215	3117	3500	57.7	15.24	500
<b>2SM 190</b>	19.5	1.19	220	3190	190	2755	230	3335	200	2900	3300	64.3	16.99	500
<b>2SM 220</b>	22.5	1.37	200	2900	170	2465	210	3045	180	2610	2800	63	16.64	500
<b>2SM 260</b>	26	1.59	180	2610	155	2248	190	2755	165	2392	2500	65	17.17	500
<b>2SM 310</b>	31.5	1.92	140	2030	120	1740	150	2175	130	1885	2200	69	18.22	500

Nota - Per valori di pressione superiori a quelli indicati contattare il Servizio Commerciale.  
Note - for higher pressure values please contact our Sales Dpt.

**DIMENSIONI • DIMENSIONS**

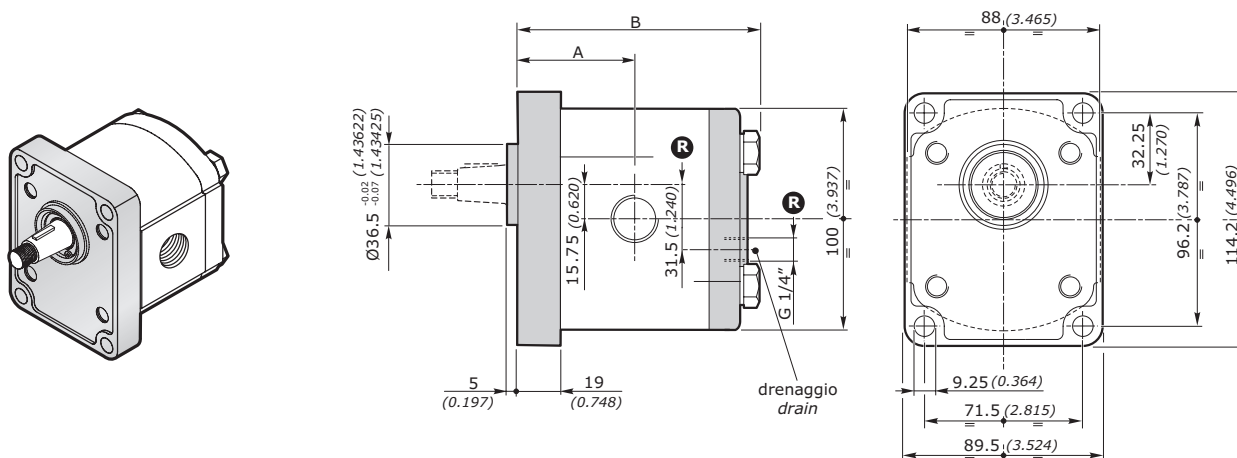

**R** Solo per motori reversibili - Only for reversible motors

GRUPPO - GROUP 2	A		B		MASSA - MASS	
	mm	inch	mm	inch	kg	lbs
<b>2SM 040</b>	44.4	1.748	93.0	3.661	3.40	7.50
<b>2SM 060</b>	46.0	1.811	96.3	3.791	3.55	7.83
<b>2SM 080</b>	48.1	1.894	100.5	3.957	3.70	8.16
<b>2SM 110</b>	50.2	1.976	104.6	4.118	3.80	8.38
<b>2SM 140</b>	52.7	2.075	109.6	4.315	3.90	8.60
<b>2SM 160</b>	54.8	2.157	113.8	4.480	4.05	8.93
<b>2SM 190</b>	57.3	2.256	118.8	4.677	4.20	9.26
<b>2SM 220</b>	59.8	2.354	123.8	4.874	4.35	9.59
<b>2SM 260</b>	62.7	2.469	129.6	5.102	4.50	9.92
<b>2SM 310</b>	66.9	2.636	138.0	5.437	4.71	7.96

**MOTORI AD INGRANAGGI GRUPPO 2SM**  
**GEAR MOTORS GROUP 2SM**
**FLANGIA SAE** **SAEA-SAEAOR** **SAE FLANGE**
**FLANGIA E COPERCHIO IN ALLUMINIO - FLANGE AND COVER IN ALUMINIUM**

GRUPPO GROUP 2SM	CILINDRATA DISPLACEMENT		PRESSIONE MAX - MAX PRESSURE								VELOCITÀ MAX MAX SPEED	PORTATA MAX MAX FLOW		VELOCITÀ MIN MIN SPEED	
	cm <sup>3</sup> /giro	in <sup>3</sup> /rev	S - D		R		S - D		R			l/min	Gal/min		giri/min - rpm
			P1 bar	P1 psi	P1 bar	P1 psi	P2 bar	P2 psi	P2 bar	P2 psi					
<b>2SM 040</b>	4	0.24	250	3625	210	3045	270	3915	230	3335	4000	16	4.23	500	
<b>2SM 060</b>	6	0.37	250	3625	210	3045	270	3915	230	3335	4000	24	6.34	500	
<b>2SM 080</b>	8.5	0.52	250	3625	210	3045	270	3915	230	3335	3500	29.7	7.85	500	
<b>2SM 110</b>	11	0.67	250	3625	210	3045	270	3915	230	3335	3500	38.5	10.17	500	
<b>2SM 140</b>	14	0.85	250	3625	210	3045	270	3915	230	3335	3500	49	12.95	500	
<b>2SM 160</b>	16.5	1.01	230	3335	195	2827	240	3480	205	2972	3500	57.7	15.24	500	
<b>2SM 190</b>	19.5	1.19	210	3045	180	2610	220	3190	190	2755	3300	64.3	16.99	500	
<b>2SM 220</b>	22.5	1.37	190	2755	160	2320	200	2900	170	2465	2800	63	16.64	500	
<b>2SM 260</b>	26	1.59	170	2465	145	2102	180	2610	155	2248	2500	65	17.17	500	
<b>2SM 310</b>	31.5	1.92	130	1885	110	1595	140	2030	120	1740	2200	69	18.22	500	

Nota - Per valori di pressione superiori a quelli indicati contattare il Servizio Commerciale.  
 Note - for higher pressure values please contact our Sales Dept.

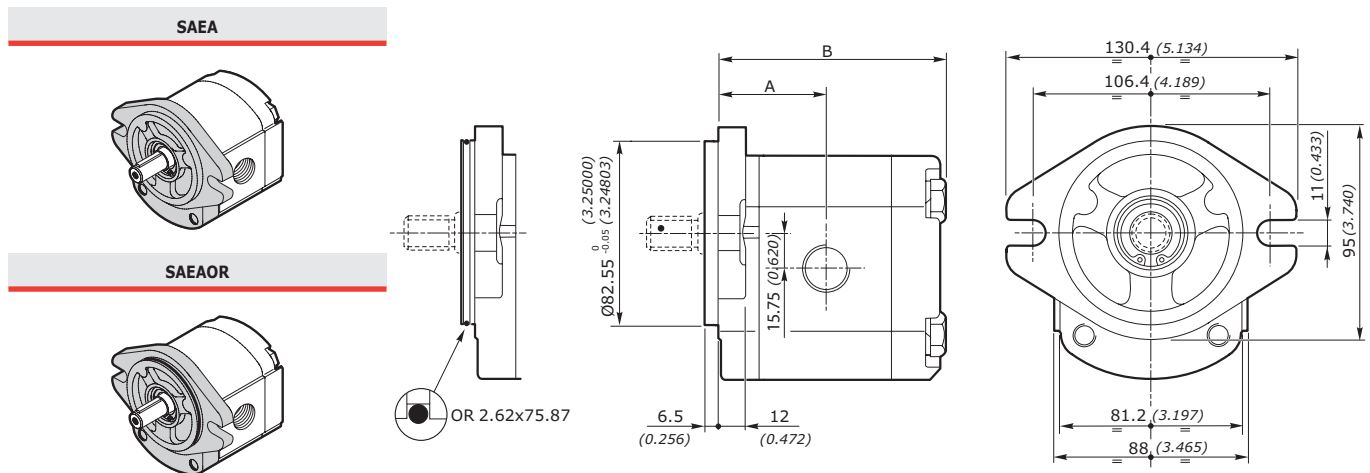
**DIMENSIONI • DIMENSIONS**

**R** Solo per motori reversibili - Only for reversible motors

GRUPPO - GROUP 2	A		B		MASSA - MASS	
	mm	inch	mm	inch	kg	lbs
<b>2SM 040</b>	44.4	1.748	93.0	3.661	2.30	5.07
<b>2SM 060</b>	46.0	1.811	96.3	3.791	2.45	5.40
<b>2SM 080</b>	48.1	1.894	100.5	3.957	2.60	5.73
<b>2SM 110</b>	50.2	1.976	104.6	4.118	2.70	5.95
<b>2SM 140</b>	52.7	2.075	109.6	4.315	2.80	6.17
<b>2SM 160</b>	54.8	2.157	113.8	4.480	2.95	6.51
<b>2SM 190</b>	57.3	2.256	118.8	4.677	3.10	6.84
<b>2SM 220</b>	59.8	2.354	123.8	4.874	3.25	7.17
<b>2SM 260</b>	62.7	2.469	129.6	5.102	3.40	7.50
<b>2SM 310</b>	66.9	2.636	138.0	5.437	3.61	7.96



**MOTORI AD INGRANAGGI GRUPPO 2SM**  
**GEAR MOTORS GROUP 2SM**

**FLANGIA SAE SAEA-SAEAOR SAE FLANGE**

**FLANGIA E COPERCHIO IN GHISA - FLANGE AND COVER IN CAST IRON**

GRUPPO GROUP 2SM	CILINDRATA DISPLACEMENT		PRESSIONE MAX - MAX PRESSURE								VELOCITÀ MAX MAX SPEED	PORTATA MAX MAX FLOW		VELOCITÀ MIN MIN SPEED
			S - D		R		S - D		R					
	cm³/giro	in³/rev	P1 bar	P1 psi	P1 bar	P1 psi	P2 bar	P2 psi	P2 bar	P2 psi	giri/min - rpm	l/min	Gal/min	giri/min - rpm
<b>2SM 040</b>	4	0.24	260	3770	220	3190	280	4060	240	3480	4000	16	4.23	500
<b>2SM 060</b>	6	0.37	260	3770	220	3190	280	4060	240	3480	4000	24	6.34	500
<b>2SM 080</b>	8.5	0.52	260	3770	220	3190	280	4060	240	3480	3500	29.7	7.85	500
<b>2SM 110</b>	11	0.67	260	3770	220	3190	280	4060	240	3480	3500	38.5	10.17	500
<b>2SM 140</b>	14	0.85	260	3770	220	3190	280	4060	240	3480	3500	49	12.95	500
<b>2SM 160</b>	16.5	1.01	240	3480	205	2972	250	3625	215	3117	3500	57.7	15.24	500
<b>2SM 190</b>	19.5	1.19	220	3190	190	2755	230	3335	200	2900	3300	64.3	16.99	500
<b>2SM 220</b>	22.5	1.37	200	2900	170	2465	210	3045	180	2610	2800	63	16.64	500
<b>2SM 260</b>	26	1.59	180	2610	155	2248	190	2755	165	2392	2500	65	17.17	500
<b>2SM 310</b>	31.5	1.92	140	2030	120	1740	150	2175	130	1885	2200	69	18.22	500

Nota - Per valori di pressione superiori a quelli indicati contattare il Servizio Commerciale.  
Note - for higher pressure values please contact our Sales Dpt.

**DIMENSIONI • DIMENSIONS**

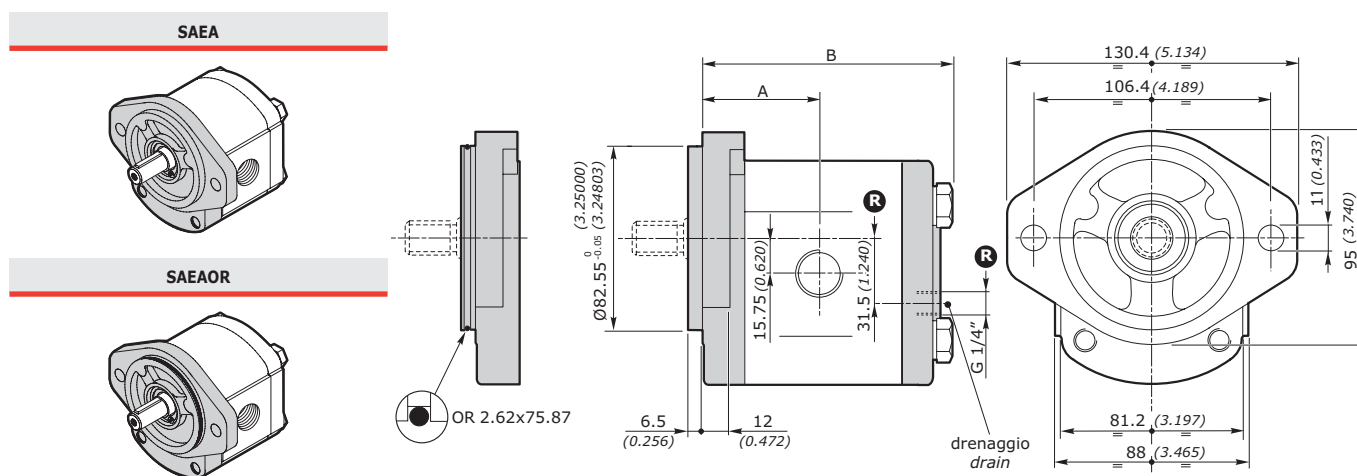

**R** Solo per motori reversibili - Only for reversible motors

GRUPPO - GROUP 2	A		B		MASSA - MASS	
	mm	inch	mm	inch	kg	lbs
<b>2SM 040</b>	44.4	1.748	93.0	3.661	3.40	7.50
<b>2SM 060</b>	46.0	1.811	96.3	3.791	3.55	7.83
<b>2SM 080</b>	48.1	1.894	100.5	3.957	3.70	8.16
<b>2SM 110</b>	50.2	1.976	104.6	4.118	3.80	8.38
<b>2SM 140</b>	52.7	2.075	109.6	4.315	3.90	8.60
<b>2SM 160</b>	54.8	2.157	113.8	4.480	4.05	8.93
<b>2SM 190</b>	57.3	2.256	118.8	4.677	4.20	9.26
<b>2SM 220</b>	59.8	2.354	123.8	4.874	4.35	9.59
<b>2SM 260</b>	62.7	2.469	129.6	5.102	4.50	9.92
<b>2SM 310</b>	66.9	2.636	138.0	5.437	4.71	7.96

**MOTORI AD INGRANAGGI GRUPPO 2SM**  
**GEAR MOTORS GROUP 2SM**
**FLANGIA TEDESCA B80C GERMAN FLANGE**

GRUPPO GROUP 2SM	CILINDRATA DISPLACEMENT		PRESSIONE MAX - MAX PRESSURE								VELOCITÀ MAX MAX SPEED	PORTATA MAX MAX FLOW		VELOCITÀ MIN MIN SPEED
			S - D		R		S - D		R					
	cm <sup>3</sup> /giro	in <sup>3</sup> /rev	P1 bar	P1 psi	P1 bar	P1 psi	P2 bar	P2 psi	P2 bar	P2 psi	giri/min - rpm	l/min	Gal/min	giri/min - rpm
<b>2SM 040</b>	4	0.24	250	3625	210	3045	270	3915	230	3335	4000	16	4.23	500
<b>2SM 060</b>	6	0.37	250	3625	210	3045	270	3915	230	3335	4000	24	6.34	500
<b>2SM 080</b>	8.5	0.52	250	3625	210	3045	270	3915	230	3335	3500	29.7	7.85	500
<b>2SM 110</b>	11	0.67	250	3625	210	3045	270	3915	230	3335	3500	38.5	10.17	500
<b>2SM 140</b>	14	0.85	250	3625	210	3045	270	3915	230	3335	3500	49	12.95	500
<b>2SM 160</b>	16.5	1.01	230	3335	195	2827	240	3480	205	2972	3500	57.7	15.24	500
<b>2SM 190</b>	19.5	1.19	210	3045	180	2610	220	3190	190	2755	3300	64.3	16.99	500
<b>2SM 220</b>	22.5	1.37	190	2755	160	2320	200	2900	170	2465	2800	63	16.64	500
<b>2SM 260</b>	26	1.59	170	2465	145	2102	180	2610	155	2248	2500	65	17.17	500
<b>2SM 310</b>	31.5	1.92	130	1885	110	1595	140	2030	120	1740	2200	69	18.22	500

Nota - Per valori di pressione superiori a quelli indicati contattare il Servizio Commerciale.  
 Note - for higher pressure values please contact our Sales Dept.

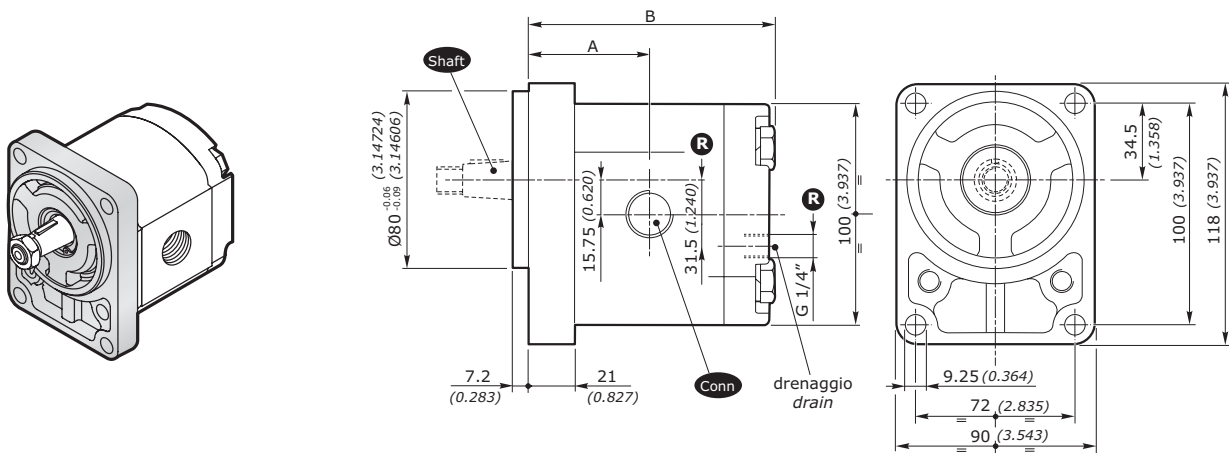
**DIMENSIONI • DIMENSIONS**

**R** Solo per motori reversibili - Only for reversible motors

GRUPPO - GROUP 2	A		B		MASSA - MASS	
	mm	inch	mm	inch	kg	lbs
<b>2SM 040</b>	46.4	1.827	95.0	3.740	2.30	5.07
<b>2SM 060</b>	48.0	1.890	98.3	3.870	2.45	5.40
<b>2SM 080</b>	50.1	1.972	102.5	4.035	2.60	5.73
<b>2SM 110</b>	52.2	2.055	106.6	4.197	2.70	5.95
<b>2SM 140</b>	54.7	2.154	111.6	4.394	2.80	6.17
<b>2SM 160</b>	56.8	2.236	115.8	4.559	2.95	6.51
<b>2SM 190</b>	59.3	2.335	120.8	4.756	3.10	6.84
<b>2SM 220</b>	61.8	2.433	125.8	4.953	3.25	7.17
<b>2SM 260</b>	64.7	2.547	131.6	5.181	3.40	7.50
<b>2SM 310</b>	68.9	2.715	140.0	5.516	3.61	7.96

**MOTORI AD INGRANAGGI GRUPPO 2SM**  
**GEAR MOTORS GROUP 2SM**

**FLANGIA B50C FLANGE**

GRUPPO GROUP 2SM	CILINDRATA DISPLACEMENT		PRESSIONE MAX - MAX PRESSURE								VELOCITÀ MAX MAX SPEED	PORTATA MAX MAX FLOW		VELOCITÀ MIN MIN SPEED
	cm³/giro	in³/rev	S - D		R		S - D		R			l/min	Gal/min	
			P1 bar	P1 psi	P1 bar	P1 psi	P2 bar	P2 psi	P2 bar	P2 psi				
<b>2SM 040</b>	4	0.24	250	3625	210	3045	270	3915	230	3335	4000	16	4.23	500
<b>2SM 060</b>	6	0.37	250	3625	210	3045	270	3915	230	3335	4000	24	6.34	500
<b>2SM 080</b>	8.5	0.52	250	3625	210	3045	270	3915	230	3335	3500	29.7	7.85	500
<b>2SM 110</b>	11	0.67	250	3625	210	3045	270	3915	230	3335	3500	38.5	10.17	500
<b>2SM 140</b>	14	0.85	250	3625	210	3045	270	3915	230	3335	3500	49	12.95	500
<b>2SM 160</b>	16.5	1.01	230	3335	195	2827	240	3480	205	2972	3500	57.7	15.24	500
<b>2SM 190</b>	19.5	1.19	210	3045	180	2610	220	3190	190	2755	3300	64.3	16.99	500
<b>2SM 220</b>	22.5	1.37	190	2755	160	2320	200	2900	170	2465	2800	63	16.64	500
<b>2SM 260</b>	26	1.59	170	2465	145	2102	180	2610	155	2248	2500	65	17.17	500
<b>2SM 310</b>	31.5	1.92	130	1885	110	1595	140	2030	120	1740	2200	69	18.22	500

Nota - Per valori di pressione superiori a quelli indicati contattare il Servizio Clienti.  
 Note - for higher pressure values please contact our Sales Dept.

**DIMENSIONI • DIMENSIONS**

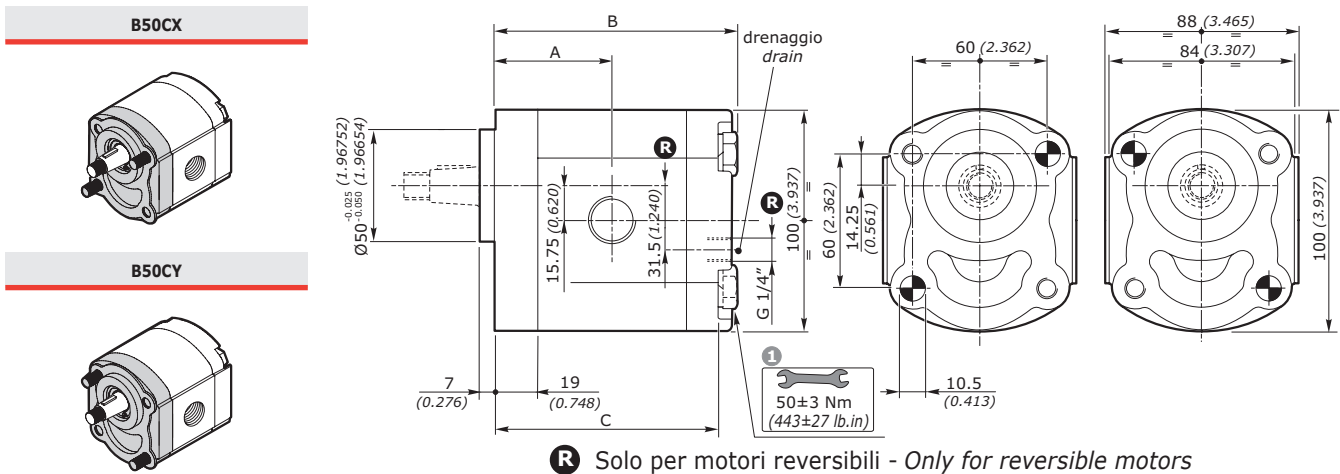

**1**  
Coppia di serraggio viti:  $50 \pm 3 \text{ Nm}$  (viti classe 10.9-12.9 UNI EN 20898/1)  
Il kit viti per il fissaggio della pompa è da ordinare separatamente.  
Codice di ordinazione: **0029W** (+ lunghezza L - vedi tabella)  
Il fissaggio del motore può essere effettuato con 2 viti prigioniere classe 10.9-12.9 UNI EN 20898/1 preserrate:  $40 \pm 3 \text{ Nm}$ . Fissare il motore mediante dadi autobloccanti con coppia di serraggio:  $50 \pm 3 \text{ Nm}$

**1**  
Screw tightening torque:  $443 \pm 27 \text{ lb-in}$  (screws 10.9-12.9 UNI EN 20898/1).  
The screw kit for the pump assembly should be ordered separately.  
Ordering code: **0029W** (+ length L - see table)  
The motor assembling should be made with 2 stud type 10.9-12.9 UNI EN 20898/1 pre-tighten  $354 \pm 27 \text{ lb-in}$  screws. Fix the motor by self-locking nuts with tightening torque:  $443 \pm 27 \text{ lb-in}$

GRUPPO - GROUP 2	A		B		C		L <sup>1</sup>		MASSA - MASS	
	mm	inch	mm	inch	mm	inch	mm	inch	kg	lbs
<b>2SM 040</b>	44.4	1.748	93.0	3.661	84.0	3.307	105	4.134	2.30	5.07
<b>2SM 060</b>	46.0	1.811	96.3	3.791	87.3	3.437	105	4.134	2.45	5.40
<b>2SM 080</b>	48.1	1.894	100.5	3.957	91.5	3.602	110	4.331	2.60	5.73
<b>2SM 110</b>	50.2	1.976	104.6	4.118	95.6	3.764	115	4.528	2.70	5.95
<b>2SM 140</b>	52.7	2.075	109.6	4.315	100.6	3.961	120	4.724	2.80	6.17
<b>2SM 160</b>	54.8	2.157	113.8	4.480	104.8	4.126	125	4.921	2.95	6.51
<b>2SM 190</b>	57.3	2.256	118.8	4.677	109.8	4.323	130	5.118	3.10	6.84
<b>2SM 220</b>	59.8	2.354	123.8	4.874	114.8	4.520	135	5.315	3.25	7.17
<b>2SM 260</b>	62.7	2.469	129.6	5.102	120.6	4.748	140	5.512	3.40	7.50
<b>2SM 310</b>	66.9	2.636	138.0	5.437	129.0	5.083	150	5.910	3.61	7.96

**MOTORI AD INGRANAGGI GRUPPO 2SM**  
**GEAR MOTORS GROUP 2SM**
**FLANGIA E52C FLANGE**

GRUPPO GROUP 2SM	CILINDRATA DISPLACEMENT		PRESSIONE MAX - MAX PRESSURE								VELOCITÀ MAX MAX SPEED		PORTATA MAX MAX FLOW		VELOCITÀ MIN MIN SPEED	
			S - D		R		S - D		R							
	cm³/giro	in³/rev	P1 bar	P1 psi	P1 bar	P1 psi	P2 bar	P2 psi	P2 bar	P2 psi	giri/min - rpm	l/min	Gal/min	giri/min - rpm		
<b>2SM 040</b>	4	0.24	250	3625	210	3045	270	3915	230	3335	4000	16	4.23	500		
<b>2SM 060</b>	6	0.37	250	3625	210	3045	270	3915	230	3335	4000	24	6.34	500		
<b>2SM 080</b>	8.5	0.52	250	3625	210	3045	270	3915	230	3335	3500	29.7	7.85	500		
<b>2SM 110</b>	11	0.67	250	3625	210	3045	270	3915	230	3335	3500	38.5	10.17	500		
<b>2SM 140</b>	14	0.85	250	3625	210	3045	270	3915	230	3335	3500	49	12.95	500		
<b>2SM 160</b>	16.5	1.01	230	3335	195	2827	240	3480	205	2972	3500	57.7	15.24	500		
<b>2SM 190</b>	19.5	1.19	210	3045	180	2610	220	3190	190	2755	3300	64.3	16.99	500		
<b>2SM 220</b>	22.5	1.37	190	2755	160	2320	200	2900	170	2465	2800	63	16.64	500		
<b>2SM 260</b>	26	1.59	170	2465	145	2102	180	2610	155	2248	2500	65	17.17	500		
<b>2SM 310</b>	31.5	1.92	130	1885	110	1595	140	2030	120	1740	2200	69	18.22	500		

Nota - Per valori di pressione superiori a quelli indicati contattare il Servizio Commerciale.  
 Note - for higher pressure values please contact our Sales Dept.

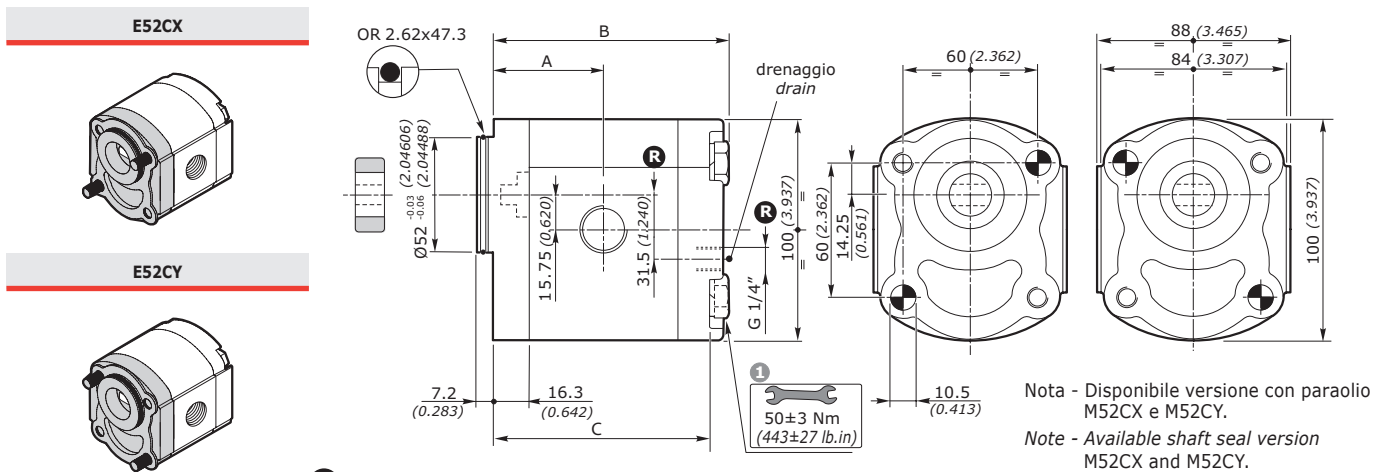
**DIMENSIONI • DIMENSIONS**

**1** Coppia di serraggio viti: 50 ± 3Nm (viti classe 10.9-12.9 UNI EN 20898/1). Il kit viti per il fissaggio del motore è da ordinare separatamente.  
**Codice di ordinazione: 0029W (+ lunghezza L - vedi tabella)**  
 Il fissaggio del motore può essere effettuato con 2 viti prigioniere classe 10.9-12.9 UNI EN 20898/1 preserrate: 40 ± 3Nm. Fissare il motore mediante dadi autobloccanti con coppia di serraggio: 50 ± 3Nm

**1** Coppia di serraggio viti: 443 ± 27 lb-in (screws 10.9-12.9 UNI EN 20898/1). The screw kit for the pump assembly should be ordered separately.  
**Ordering code: 0029W (+ length L - see table)**  
 The motor assembling should be made with 2 stud type 10.9-12.9 UNI EN 20898/1 pre-tighten 354 ± 27 lb-in screws. Fix the motor by self-locking nuts with tightening torque: 443 ± 27 lb-in

GRUPPO - GROUP 2	A		B		C		L <sup>1</sup>		MASSA - MASS	
	mm	inch	mm	inch	mm	inch	mm	inch	kg	lbs
<b>2SP 040</b>	41.7	1.642	90.3	3.555	81.3	3.201	100	3.937	2.30	5.07
<b>2SP 060</b>	43.3	1.705	93.6	3.685	84.6	3.331	105	4.134	2.45	5.40
<b>2SP 080</b>	45.4	1.787	97.8	3.850	88.8	3.496	110	4.331	2.60	5.73
<b>2SP 110</b>	47.5	1.870	101.9	4.012	92.9	3.657	115	4.528	2.70	5.95
<b>2SP 140</b>	50.0	1.969	106.9	4.209	97.9	3.854	120	4.724	2.80	6.17
<b>2SP 160</b>	52.1	2.051	111.1	4.374	102.1	4.020	120	4.724	2.95	6.51
<b>2SP 190</b>	54.6	2.150	116.1	4.571	107.1	4.217	125	4.921	3.10	6.84
<b>2SP 220</b>	57.1	2.248	121.1	4.768	112.1	4.413	130	5.118	3.25	7.17
<b>2SP 260</b>	60.0	2.362	126.9	4.996	117.9	4.642	140	5.512	3.40	7.50
<b>2SP 310</b>	64.2	2.529	135.3	5.331	126.3	4.988	145	5.713	3.61	7.96

**MOTORI AD INGRANAGGI GRUPPO 2SM**  
**GEAR MOTORS GROUP 2SM**

VERSIONE DA UTILIZZARE IN PRESENZA DI CARICHI ASSIALI E/O RADIALI  
 VERSION TO BE USED WITH AXIAL AND/OR RADIAL LOADS

**FLANGIA SUPEUR FLANGE**

GRUPPO GROUP 2SM	CILINDRATA DISPLACEMENT		PRESSIONE MAX - MAX PRESSURE								VELOCITÀ MAX MAX SPEED	PORTATA MAX MAX FLOW		VELOCITÀ MIN MIN SPEED
			S - D		R		S - D		R					
	cm³/giro	in³/rev	P1 bar	P1 psi	P1 bar	P1 psi	P2 bar	P2 psi	P2 bar	P2 psi	giri/min - rpm	l/min	Gal/min	giri/min - rpm
<b>2SM 040</b>	4	0.24	250	3625	210	3045	270	3915	230	3335	4000	16	4.23	500
<b>2SM 060</b>	6	0.37	250	3625	210	3045	270	3915	230	3335	4000	24	6.34	500
<b>2SM 080</b>	8.5	0.52	250	3625	210	3045	270	3915	230	3335	3500	29.7	7.85	500
<b>2SM 110</b>	11	0.67	250	3625	210	3045	270	3915	230	3335	3500	38.5	10.17	500
<b>2SM 140</b>	14	0.85	250	3625	210	3045	270	3915	230	3335	3500	49	12.95	500
<b>2SM 160</b>	16.5	1.01	230	3335	195	2827	240	3480	205	2972	3500	57.7	15.24	500
<b>2SM 190</b>	19.5	1.19	210	3045	180	2610	220	3190	190	2755	3300	64.3	16.99	500
<b>2SM 220</b>	22.5	1.37	190	2755	160	2320	200	2900	170	2465	2800	63	16.64	500
<b>2SM 260</b>	26	1.59	170	2465	145	2102	180	2610	155	2248	2500	65	17.17	500
<b>2SM 310</b>	31.5	1.92	130	1885	110	1595	140	2030	120	1740	2200	69	18.22	500

Nota - Per valori di pressione superiori a quelli indicati contattare il Servizio Commerciale.  
 Note - for higher pressure values please contact our Sales Dpt.

**DIMENSIONI • DIMENSIONS**

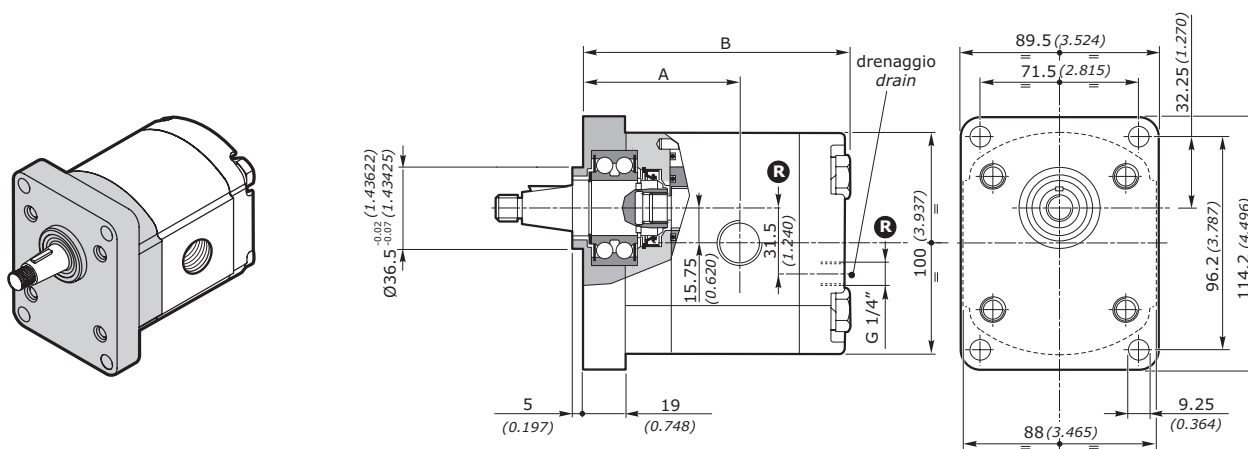

**R** Solo per motori reversibili - Only for reversible motors

La flangia SUPEUR è sempre allestita con anello di rinforzo. *SUPEUR flange is always equipped with sealing ring*

GRUPPO - GROUP 2	A		B		MASSA - MASS	
	mm	inch	mm	inch	kg	lbs
<b>2SP 040</b>	64.4	2.535	113.0	4.449	2.80	6.17
<b>2SP 060</b>	66.0	2.598	116.3	4.579	2.95	6.50
<b>2SP 080</b>	68.1	2.681	120.5	4.744	3.10	6.84
<b>2SP 110</b>	70.2	2.764	124.6	4.906	3.20	7.06
<b>2SP 140</b>	72.7	2.863	129.6	5.102	3.30	7.28
<b>2SP 160</b>	74.8	2.945	133.8	5.268	3.45	7.61
<b>2SP 190</b>	77.3	3.043	138.8	5.465	3.60	7.94
<b>2SP 220</b>	79.8	3.142	143.8	5.661	3.75	8.27
<b>2SP 260</b>	82.7	3.256	149.6	5.890	3.90	8.60
<b>2SP 310</b>	86.9	3.424	158.0	6.225	4.11	9.06

**MOTORI AD INGRANAGGI GRUPPO 2SM**  
**GEAR MOTORS GROUP 2SM**
**FLANGIA SUPEUR FLANGE**
**FLANGIA E COPERCHIO IN GHISA - FLANGE AND COVER IN CAST IRON**

GRUPPO GROUP 2SM	CILINDRATA DISPLACEMENT		PRESSIONE MAX - MAX PRESSURE								VELOCITÀ MAX MAX SPEED	PORTATA MAX MAX FLOW		VELOCITÀ MIN MIN SPEED
			S - D		R		S - D		R					
	cm <sup>3</sup> /giro	in <sup>3</sup> /rev	P1 bar	P1 psi	P1 bar	P1 psi	P2 bar	P2 psi	P2 bar	P2 psi	giri/min - rpm	l/min	Gal/min	giri/min - rpm
2SM 040	4	0.24	260	3770	220	3190	280	4060	240	3480	4000	16	4.23	500
2SM 060	6	0.37	260	3770	220	3190	280	4060	240	3480	4000	24	6.34	500
2SM 080	8.5	0.52	260	3770	220	3190	280	4060	240	3480	3500	29.7	7.85	500
2SM 110	11	0.67	260	3770	220	3190	280	4060	240	3480	3500	38.5	10.17	500
2SM 140	14	0.85	260	3770	220	3190	280	4060	240	3480	3500	49	12.95	500
2SM 160	16.5	1.01	240	3480	205	2972	250	3625	215	3117	3500	57.7	15.24	500
2SM 190	19.5	1.19	220	3190	190	2755	230	3335	200	2900	3300	64.3	16.99	500
2SM 220	22.5	1.37	200	2900	170	2465	210	3045	180	2610	2800	63	16.64	500
2SM 260	26	1.59	180	2610	155	2248	190	2755	165	2392	2500	65	17.17	500
2SM 310	31.5	1.92	140	2030	120	1740	150	2175	130	1885	2200	69	18.22	500

Nota - Per valori di pressione superiori a quelli indicati contattare il Servizio Commerciale.  
 Note - for higher pressure values please contact our Sales Dpt.

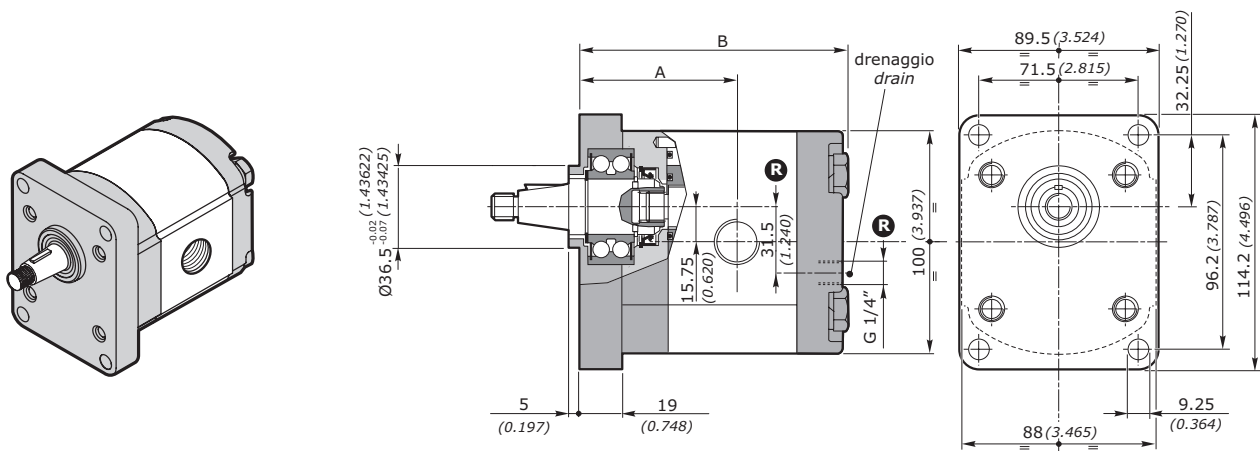
**DIMENSIONI • DIMENSIONS**

**R** Solo per motori reversibili - Only for reversible motors

La flangia SUPEUR è sempre allestita con anello di rinforzo. *SUPEUR flange is always equipped with sealing ring*

GRUPPO - GROUP 2	A		B		MASSA - MASS	
	mm	inch	mm	inch	kg	lbs
2SM 040	64.4	2.535	113.0	4.449	3.467	7.643
2SM 060	66.0	2.598	116.3	4.579	3.617	7.974
2SM 080	68.1	2.681	120.5	4.744	3.767	8.304
2SM 110	70.2	2.764	124.6	4.906	3.867	8.525
2SM 140	72.7	2.863	129.6	5.102	3.967	8.745
2SM 160	74.8	2.945	133.8	5.268	4.117	9.076
2SM 190	77.3	3.043	138.8	5.465	4.267	9.407
2SM 220	79.8	3.142	143.8	5.661	4.417	9.737
2SM 260	82.7	3.256	149.6	5.890	4.567	10.068
2SM 310	86.9	3.424	158.0	6.225	4.777	10.531

**MOTORI AD INGRANAGGI GRUPPO 2SM**  
**GEAR MOTORS GROUP 2SM**

**FLANGIA SAE SAEB\* (1) SAEB FLANGE**

**FLANGIA E COPERCHIO IN GHISA - FLANGE AND COVER IN CAST IRON**

GRUPPO GROUP 2SM	CILINDRATA DISPLACEMENT		PRESSIONE MAX - MAX PRESSURE								VELOCITÀ MAX MAX SPEED	PORTATA MAX MAX FLOW		VELOCITÀ MIN MIN SPEED
			S - D		R		S - D		R					
	cm³/giro	in³/rev	P1 bar	P1 psi	P1 bar	P1 psi	P2 bar	P2 psi	P2 bar	P2 psi	giri/min - rpm	l/min	Gal/min	giri/min - rpm
<b>2SM 040</b>	4	0.24	260	3770	220	3190	280	4060	240	3480	4000	16	4.23	500
<b>2SM 060</b>	6	0.37	260	3770	220	3190	280	4060	240	3480	4000	24	6.34	500
<b>2SM 080</b>	8.5	0.52	260	3770	220	3190	280	4060	240	3480	3500	29.7	7.85	500
<b>2SM 110</b>	11	0.67	260	3770	220	3190	280	4060	240	3480	3500	38.5	10.17	500
<b>2SM 140</b>	14	0.85	260	3770	220	3190	280	4060	240	3480	3500	49	12.95	500
<b>2SM 160</b>	16.5	1.01	240	3480	205	2972	250	3625	215	3117	3500	57.7	15.24	500
<b>2SM 190</b>	19.5	1.19	220	3190	190	2755	230	3335	200	2900	3300	64.3	16.99	500
<b>2SM 220</b>	22.5	1.37	200	2900	170	2465	210	3045	180	2610	2800	63	16.64	500
<b>2SM 260</b>	26	1.59	180	2610	155	2248	190	2755	165	2392	2500	65	17.17	500
<b>2SM 310</b>	31.5	1.92	140	2030	120	1740	150	2175	130	1885	2200	69	18.22	500

Nota - Per valori di pressione superiori a quelli indicati contattare il Servizio Commerciale.  
 Note - for higher pressure values please contact our Sales Dpt.

\* Contattare il servizio commerciale. / Available soon. Please contact our Sales Dpt.

**DIMENSIONI • DIMENSIONS**

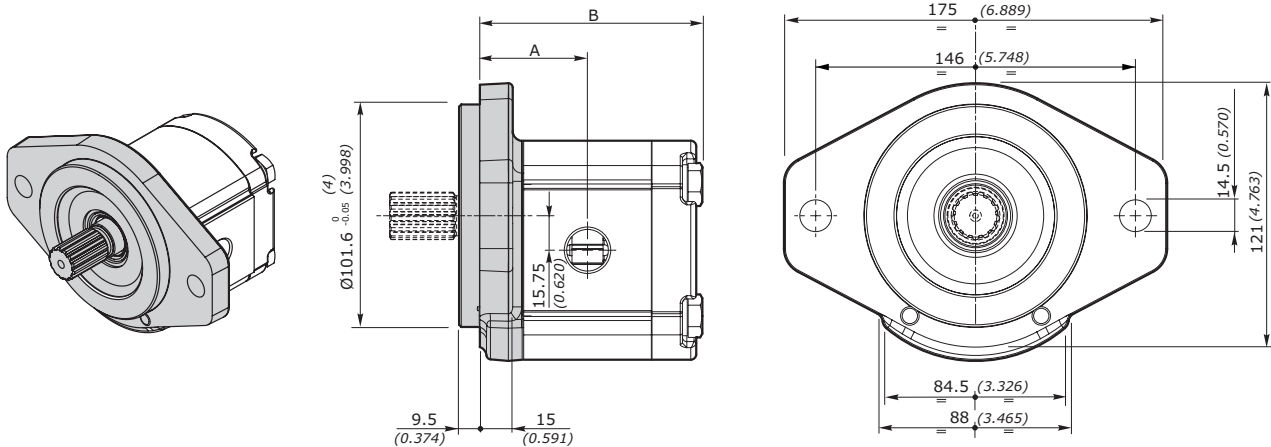

(1) Configurabile come motore unidirezionale; elementi interni non intercambiabili  
 Configuration as unidirectional gear motor; internal elements are not interchangeable

GRUPPO - GROUP 2	A		B		MASSA - MASS	
	mm	inch	mm	inch	kg	lbs
<b>2SM 040</b>	45.4	1.787	94	3.701	4.90	10.80
<b>2SM 060</b>	47.0	1.850	97.3	3.831	5.05	11.13
<b>2SM 080</b>	49.1	1.933	101.5	3.996	5.20	11.46
<b>2SM 110</b>	51.2	2.016	105.6	4.157	5.30	11.68
<b>2SM 140</b>	53.7	2.114	110.6	4.354	5.40	11.90
<b>2SM 160</b>	55.8	2.197	114.8	4.520	5.55	12.24
<b>2SM 190</b>	58.3	2.295	119.8	4.717	5.70	12.57
<b>2SM 220</b>	60.8	2.394	124.8	4.913	5.85	12.90
<b>2SM 260</b>	63.7	2.508	130.6	5.142	6.00	13.23
<b>2SM 310</b>	67.9	2.673	139	5.472	6.20	13.67

**MOTORI AD INGRANAGGI GRUPPO 2SM**  
**GEAR MOTORS GROUP 2SM**
**FLANGIA SUPSAE FLANGE**
**FLANGIA E COPERCHIO IN ALLUMINIO - FLANGE AND COVER IN ALUMINIUM**

GRUPPO GROUP 2SM	CILINDRATA DISPLACEMENT		PRESSIONE MAX - MAX PRESSURE								VELOCITÀ MAX MAX SPEED	PORTATA MAX MAX FLOW		VELOCITÀ MIN MIN SPEED
			S - D		R		S - D		R					
	cm³/giro	in³/rev	P1 bar	P1 psi	P1 bar	P1 psi	P2 bar	P2 psi	P2 bar	P2 psi	giri/min - rpm	l/min	Gal/min	giri/min - rpm
<b>2SM 040</b>	4	0.24	250	3625	210	3045	270	3915	230	3335	4000	16	4.23	500
<b>2SM 060</b>	6	0.37	250	3625	210	3045	270	3915	230	3335	4000	24	6.34	500
<b>2SM 080</b>	8.5	0.52	250	3625	210	3045	270	3915	230	3335	3500	29.7	7.85	500
<b>2SM 110</b>	11	0.67	250	3625	210	3045	270	3915	230	3335	3500	38.5	10.17	500
<b>2SM 140</b>	14	0.85	250	3625	210	3045	270	3915	230	3335	3500	49	12.95	500
<b>2SM 160</b>	16.5	1.01	230	3335	195	2827	240	3480	205	2972	3500	57.7	15.24	500
<b>2SM 190</b>	19.5	1.19	210	3045	180	2610	220	3190	190	2755	3300	64.3	16.99	500
<b>2SM 220</b>	22.5	1.37	190	2755	160	2320	200	2900	170	2465	2800	63	16.64	500
<b>2SM 260</b>	26	1.59	170	2465	145	2102	180	2610	155	2248	2500	65	17.17	500
<b>2SM 310</b>	31.5	1.92	130	1885	110	1595	140	2030	120	1740	2200	69	18.22	500

Nota - Per valori di pressione superiori a quelli indicati contattare il Servizio Commerciale.  
 Note - for higher pressure values please contact our Sales Dpt.

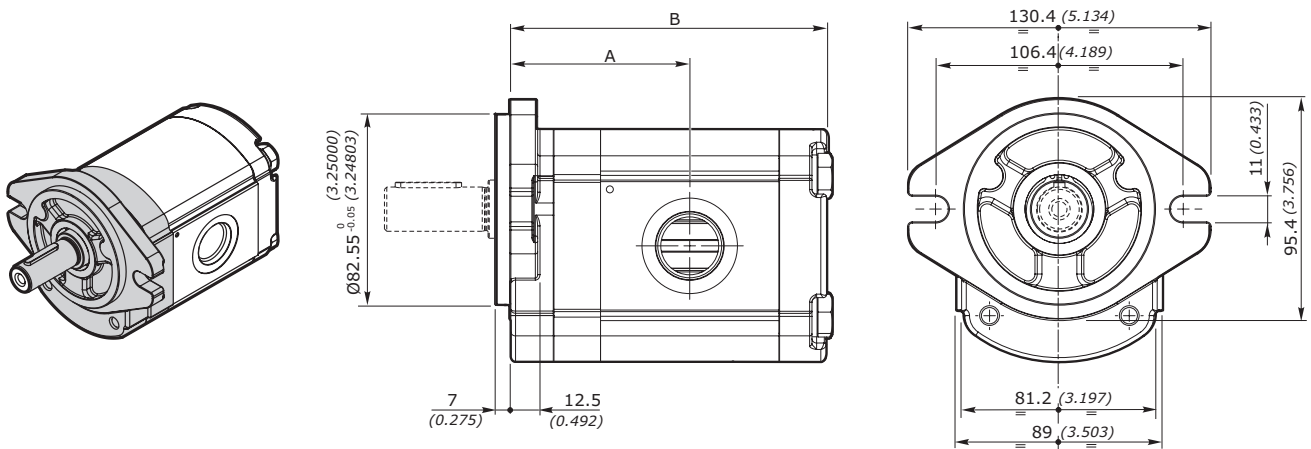
**DIMENSIONI • DIMENSIONS**

GRUPPO - GROUP 2	A		B		MASSA - MASS	
	mm	inch	mm	inch	kg	lbs
<b>2SM 040</b>	64.4	2.535	113.0	4.448	2.80	6.172
<b>2SM 060</b>	66.0	2.598	116.3	4.578	2.95	6.503
<b>2SM 080</b>	68.1	2.681	120.5	4.744	3.10	6.834
<b>2SM 110</b>	70.2	2.763	124.6	4.905	3.20	7.054
<b>2SM 140</b>	72.7	2.862	129.6	5.102	3.30	7.275
<b>2SM 160</b>	74.8	2.944	133.8	5.267	3.45	7.605
<b>2SM 190</b>	77.3	3.043	138.8	5.464	3.60	7.936
<b>2SM 220</b>	79.8	3.141	143.8	5.661	3.75	8.267
<b>2SM 260</b>	82.7	3.255	149.6	5.889	3.90	8.598
<b>2SM 310</b>	86.9	3.421	138.0	6.220	4.10	9.038



**MOTORI AD INGRANAGGI GRUPPO 2SM**  
**GEAR MOTORS GROUP 2SM**

**FLANGIA SUPB80C FLANGE**

GRUPPO GROUP 2SM	CILINDRATA DISPLACEMENT		PRESSIONE MAX - MAX PRESSURE								VELOCITÀ MAX MAX SPEED	PORTATA MAX MAX FLOW		VELOCITÀ MIN MIN SPEED
			S - D		R		S - D		R					
	cm³/giro	in³/rev	P1 bar	P1 psi	P1 bar	P1 psi	P2 bar	P2 psi	P2 bar	P2 psi	giri/min - rpm	l/min	Gal/min	giri/min - rpm
<b>2SM 040</b>	4	0.24	250	3625	210	3045	270	3915	230	3335	4000	16	4.23	500
<b>2SM 060</b>	6	0.37	250	3625	210	3045	270	3915	230	3335	4000	24	6.34	500
<b>2SM 080</b>	8.5	0.52	250	3625	210	3045	270	3915	230	3335	3500	29.7	7.85	500
<b>2SM 110</b>	11	0.67	250	3625	210	3045	270	3915	230	3335	3500	38.5	10.17	500
<b>2SM 140</b>	14	0.85	250	3625	210	3045	270	3915	230	3335	3500	49	12.95	500
<b>2SM 160</b>	16.5	1.01	230	3335	195	2827	240	3480	205	2972	3500	57.7	15.24	500
<b>2SM 190</b>	19.5	1.19	210	3045	180	2610	220	3190	190	2755	3300	64.3	16.99	500
<b>2SM 220</b>	22.5	1.37	190	2755	160	2320	200	2900	170	2465	2800	63	16.64	500
<b>2SM 260</b>	26	1.59	170	2465	145	2102	180	2610	155	2248	2500	65	17.17	500
<b>2SM 310</b>	31.5	1.92	130	1885	110	1595	140	2030	120	1740	2200	69	18.22	500

Nota - Per valori di pressione superiori a quelli indicati contattare il Servizio Commerciale.  
Note - for higher pressure values please contact our Sales Dept.

**DIMENSIONI • DIMENSIONS**

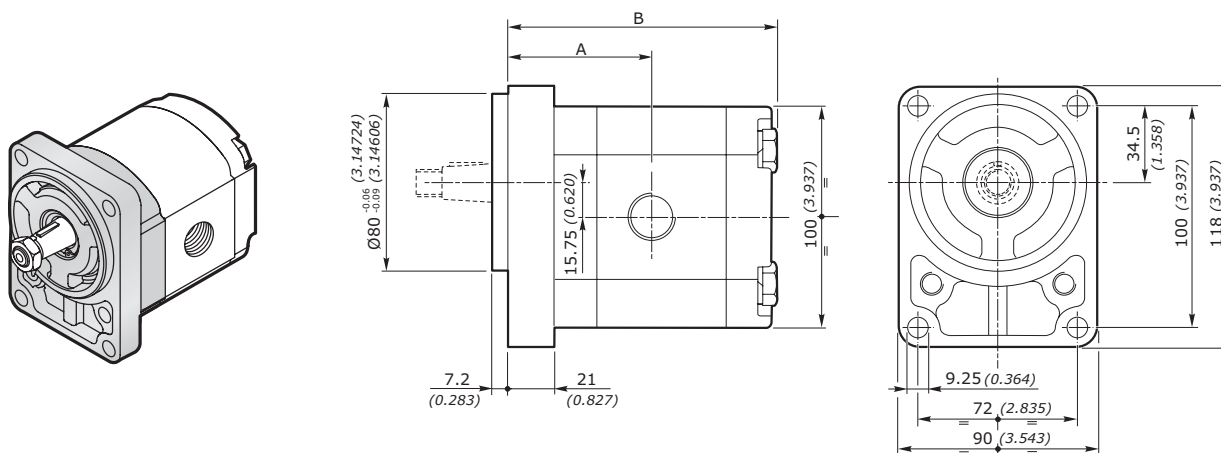

GRUPPO - GROUP 2	A		B		MASSA - MASS	
	mm	inch	mm	inch	kg	lbs
<b>2SM 040</b>	66.4	2.614	115.0	4.527	2.763	6.09
<b>2SM 060</b>	68	2.677	118.3	4.657	2.913	6.42
<b>2SM 080</b>	70.1	2.760	122.5	4.823	3.063	6.75
<b>2SM 110</b>	72.2	2.842	126.6	4.984	3.163	6.97
<b>2SM 140</b>	74.7	2.941	131.6	5.181	3.263	7.20
<b>2SM 160</b>	76.8	3.023	135.8	5.346	3.413	7.52
<b>2SM 190</b>	79.3	3.122	140.8	5.543	3.563	7.85
<b>2SM 220</b>	81.8	3.220	145.8	5.740	3.713	8.18
<b>2SM 260</b>	84.7	3.334	151.6	5.968	3.863	8.52
<b>2SM 310</b>	88.9	3.500	160.0	6.299	4.073	8.98

**MOTORI AD INGRANAGGI GRUPPO 2SM**  
**GEAR MOTORS GROUP 2SM**
**FLANGIA SUPB50CX FLANGE**

GRUPPO GROUP 2SM	CILINDRATA DISPLACEMENT		PRESSIONE MAX - MAX PRESSURE								VELOCITÀ MAX MAX SPEED	PORTATA MAX MAX FLOW		VELOCITÀ MIN MIN SPEED
			S - D		R		S - D		R					
	cm³/ giro	in³/ rev	P1 bar	P1 psi	P1 bar	P1 psi	P2 bar	P2 psi	P2 bar	P2 psi	giri/min - rpm	l/min	Gal/min	giri/min - rpm
<b>2SM 040</b>	4	0.24	250	3625	210	3045	270	3915	230	3335	4000	16	4.23	500
<b>2SM 060</b>	6	0.37	250	3625	210	3045	270	3915	230	3335	4000	24	6.34	500
<b>2SM 080</b>	8.5	0.52	250	3625	210	3045	270	3915	230	3335	3500	29.7	7.85	500
<b>2SM 110</b>	11	0.67	250	3625	210	3045	270	3915	230	3335	3500	38.5	10.17	500
<b>2SM 140</b>	14	0.85	250	3625	210	3045	270	3915	230	3335	3500	49	12.95	500
<b>2SM 160</b>	16.5	1.01	230	3335	195	2827	240	3480	205	2972	3500	57.7	15.24	500
<b>2SM 190</b>	19.5	1.19	210	3045	180	2610	220	3190	190	2755	3300	64.3	16.99	500
<b>2SM 220</b>	22.5	1.37	190	2755	160	2320	200	2900	170	2465	2800	63	16.64	500
<b>2SM 260</b>	26	1.59	170	2465	145	2102	180	2610	155	2248	2500	65	17.17	500
<b>2SM 310</b>	31.5	1.92	130	1885	110	1595	140	2030	120	1740	2200	69	18.22	500

Nota - Per valori di pressione superiori a quelli indicati contattare il Servizio Commerciale.  
 Note - for higher pressure values please contact our Sales Dpt.

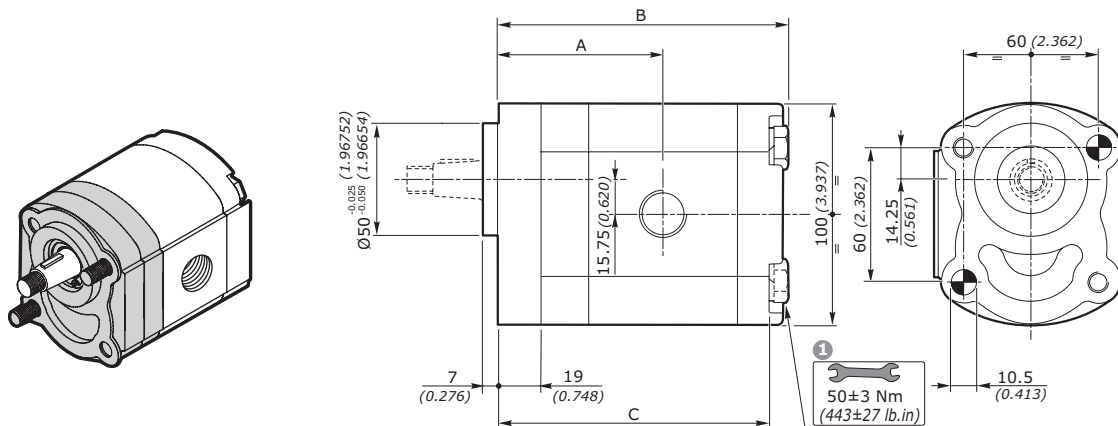
**DIMENSIONI • DIMENSIONS**

**1**

Coppia di serraggio viti:  $50 \pm 3 \text{ Nm}$  (viti classe 10.9-12.9 UNI EN 20898/1)  
 Il kit viti per il fissaggio della pompa è da ordinare separatamente.  
 Codice di ordinazione: **0029W** (+ lunghezza **L** - vedi tabella)  
 Il fissaggio della pompa può essere effettuato con 2 viti prigioniere classe 10.9-12.9 UNI EN 20898/1 preserrate:  $40 \pm 3 \text{ Nm}$ . Fissare la pompa mediante dadi autobloccanti con coppia di serraggio:  $50 \pm 3 \text{ Nm}$

**1**

Screw tightening torque:  $443 \pm 27 \text{ lb.in}$  (screws 10.9-12.9 UNI EN 20898/1).  
 The screw kit for the pump assembly should be ordered separately.  
 Ordering code: **0029W** (+ length **L** - see table)  
 The pump assembling should be made with 2 screws stud type 10.9-12.9 UNI EN 20898/1 pre-tighten  $354 \pm 27 \text{ lb.in}$ . Fix the pump by self-locking nuts with tightening torque:  $443 \pm 27 \text{ lb.in}$

GRUPPO - GROUP 2	A		B		C		L <sup>1</sup>		MASSA - MASS	
	mm	inch	mm	inch	mm	inch	mm	inch	kg	lbs
<b>2SM 040</b>	64.4	2.535	113.0	4.448	104.0	4.094	125	4.921	2.76	6.08
<b>2SM 060</b>	66.0	2.598	116.3	4.578	107.3	4.224	125	4.921	2.91	6.41
<b>2SM 080</b>	68.1	2.681	120.5	4.744	111.5	4.390	130	5.118	3.06	6.75
<b>2SM 110</b>	70.2	2.763	124.6	4.905	115.6	4.551	135	5.314	3.16	6.97
<b>2SM 140</b>	72.7	2.862	129.6	5.102	120.6	4.748	140	5.512	3.26	7.19
<b>2SM 160</b>	74.8	2.944	133.8	5.267	124.8	4.913	145	5.709	3.41	7.52
<b>2SM 190</b>	77.3	3.043	138.8	5.464	129.8	5.110	150	5.905	3.56	7.85
<b>2SM 220</b>	79.8	3.141	143.8	5.661	134.8	5.307	155	6.102	3.71	8.18
<b>2SM 260</b>	82.7	3.256	149.6	5.890	140.6	5.535	160	6.299	3.86	8.51
<b>2SM 310</b>	86.9	3.421	158.0	6.220	149.0	5.866	170	6.692	4.07	8.97

**MOTORI AD INGRANAGGI GRUPPO 2SM**  
**GEAR MOTORS GROUP 2SM**

**CARICO DINAMICO EQUIVALENTE • EQUIVALENT DYNAMIC LOAD**

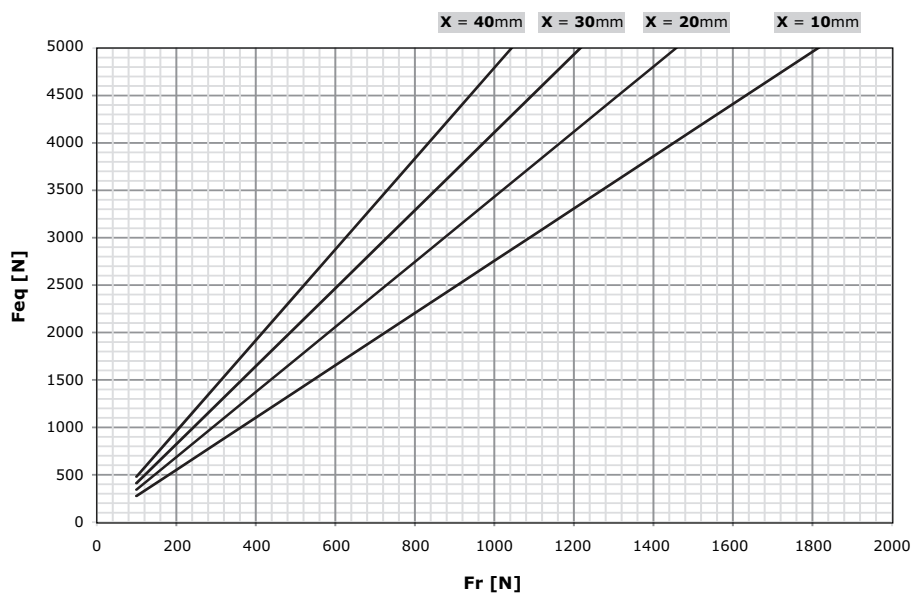
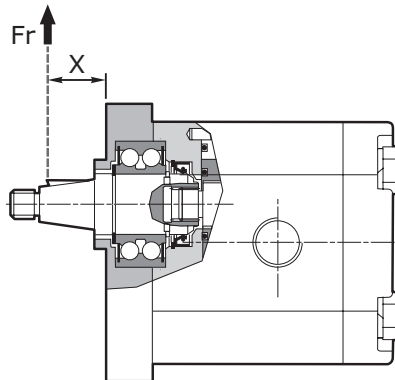

In caso di carichi combinati applicati all'albero (radiale + assiale) contattare il nostro Ufficio Tecnico.  
 In case of both radial and axial loads applied to the shaft please contact our technical department.

**DIAGRAMMA CUSCINETTI • DIAGRAM BEARING EXPECTED LIFE**

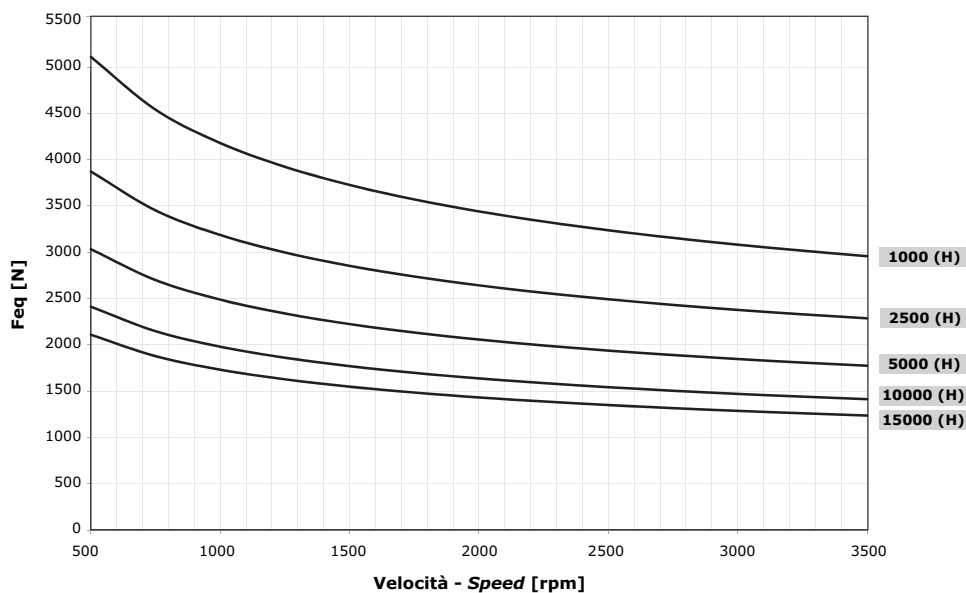

**MOTORI AD INGRANAGGI GRUPPO 2SM**  
**GEAR MOTORS GROUP 2SM**
**CODICE ORDINAZIONE • ORDER CODE**
**2SM - G - 140 - D - EUR - H - N - 10 - 0 - G**

SIGLA - CODE	TIPO - TYPE	DESCRIZIONE - DESCRIPTION	PAGINA - PAGE
<b>2SM</b>	Tipo motore <i>Motor type</i>	Motore - gruppo 2 <i>Motor - group 2</i>	101
<b>G</b>	Materiale flangia e coperchio <i>Flange and cover material</i>	<b>A</b> = alluminio / <i>aluminium</i> <b>G</b> = Ghisa / <i>Cast iron</i>	139
<b>140</b>	Cilindrata <i>Displacement</i>	Cilindrata = 14 cm <sup>3</sup> /g <i>Displacement = 0.85 in<sup>3</sup>/rev</i>	101
<b>D</b>	Senso di rotazione <i>Rotation wise</i>	<b>D</b> = Rotazione destra / <i>Clockwise rotation</i> <b>S</b> = Rotazione sinistra / <i>Anticlockwise rotation</i> <b>R</b> = Reversibile / <i>Reversible</i> <b>X</b> = Reversibile con drenaggio interno <i>Reversible with internal drain</i>	104
<b>EUR</b>	Tipo Flangia <i>Flange type</i>	Flangia standard <i>Standard flange</i>	139
<b>H</b>	Tipo anello di tenuta <i>Seal ring type</i>	Vedi tabella compatibilità <i>See compatibility table</i>	
<b>N</b>	Tipo guarnizione <i>Gasket type</i>	<b>N</b> = NBR <b>V</b> = Viton	140
<b>10</b>	Tipo Albero <i>Shaft type</i>	Vedi tabella compatibilità <i>See compatibility table</i>	
<b>0</b>	Posizione connessione <i>Connection position</i>	Vedi tabella compatibilità <i>See compatibility table</i>	144
<b>G</b>	Tipo connessione <i>Connection type</i>	Vedi tabella compatibilità <i>See compatibility table</i>	145

**VERSIONI CON DOPPIO PARAOLIO • DOUBLE SHAFT SEAL VERSION**

Disponibili versioni con doppio paraolio per EUR, SAEA, SAEAOR e B50C.

Available versions with double shaft seal for EUR, SAEA, SAEAOR and B50C.

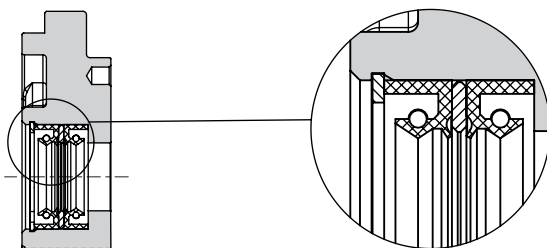

esempio • example:

**2SM - A - 140 - D - EUR - SAE2 - N - 10 - 0 - G**
**SAE2**= Doppio paraolio / *Double Shaft Seal*

Nota - La versione con paraolio è fornita con anelli a bassa pressione o alta pressione tipo K. (vedi pag.139).

Note - The version with shaft seal is supplied with K rings type with low pressure or high pressure. (see page 139).

**MOTORI AD INGRANAGGI GRUPPO 2SM**  
**GEAR MOTORS GROUP 2SM**

**TIPOLOGIA FLANGIA • FLANGE TYPE**

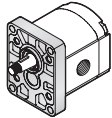
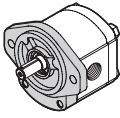
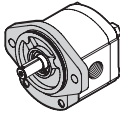
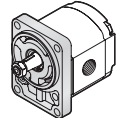
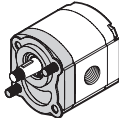
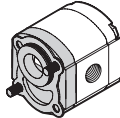
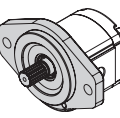
	EUR	SAEA	SAEAOR	B80C	B50C	E52C	SAEB*
<b>2SM</b>							
<b>A</b> alluminio aluminium	◇	◇	◇	◇	◇	◇	non disponibile not available
<b>G</b> ghisa cast iron	◇	◇	◇	non disponibile not available	non disponibile not available	non disponibile not available	◇

◇ = Combinazione standard - Standard combination

\* Contattare il servizio commerciale. / Available soon. Please contact our Sales Dpt.

**ANELLO DI TENUTA • SEAL RING**

SIGLA - CODE	TIPO - TYPE	DIAGRAMMA - DIAGRAM
--------------	-------------	---------------------

**A** Flangia senza anello di tenuta  
 Flange without seal ring

/

**H** Anello di tenuta fino a **8 bar**  
 Sealing ring up to **8 bar**

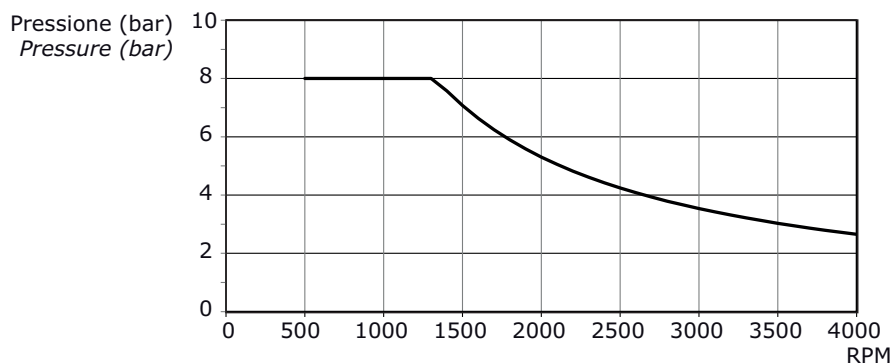

**K** Anello di tenuta fino a **30 bar**  
 Sealing ring up to **30 bar**

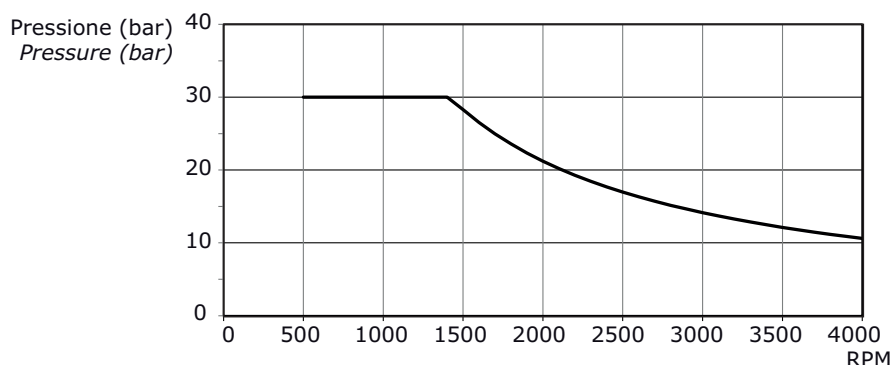

**MOTORI AD INGRANAGGI GRUPPO 2SM**  
**GEAR MOTORS GROUP 2SM**
**COMBINAZIONE FLANGIA - ANELLO DI TENUTA - GUARNIZIONE • FLANGE - SEAL RING - GASKET COMBINATION**

2SM	EUR			SAEA			SAEAOR			B80C			B50C			E52C	SAEB*
	Anello - Seal ring			Anello - Seal ring			Anello - Seal ring			Anello - Seal ring			Anello - Seal ring			Anello - Seal ring	Anello-Seal ring
	H	K	W	H	K	W	H	K	W	H	K	W	H	K	W	A	H
NBR	N	◇	◇	◇	◇	◇	◇	◇	◇	◇	◇	◇	◇	◇	◇	◇	◇
Viton	V	●	●	●	●	●	●	●	●	●	●	●	●	●	●	●	●

 esempio • example: **1SM - A - 140 - D - EUR - H - N - 10 - 0 - G**
**EUR** = Flangia europea / European flange

**H** = Anello tenuta fino a 8 bar / Seal ring up to 8 bar

**N** = Guarnizione in NBR / NBR o-ring

**COMBINAZIONE ALBERO - FLANGIA • SHAFT - FLANGE COMBINATION**

2SM	EUR	SAEA	SAEAOR	B80C	B50C	E52C	SAEB*
<b>10</b> Conico 1:8-Tapered 1:8	◇	●	●	●	◇		●
<b>11</b> Conico 1:5-Tapered 1:5	●	●	●	◇	●		●
<b>12</b> Cilindrico EUR-EUR Parallel shaft	●	●	●	●	●		●
<b>13</b> Cilindrico SAEA-SAEA parallel shaft	●	◇	◇	●	●		●
<b>14</b> Scanalato SAEA 9T-SAEA 9T splined	●	◇	◇	●	●		●
<b>15</b> Scanalato DIN5482 9T (26/24) DIN5482 9T splined (26/24)	●	●	●	◇	●		●
<b>16</b> Scanalato DIN5482 9T (20)-DIN5482 9T splined (20)	●	●	●	◇	●		●
<b>17</b> Fresato a dente frontale-Dihedral claw						◇	
<b>40</b> Scanalato SAE 10 denti (52)-SAE 10T splined (52)		●	●				●
<b>41</b> Scanalato SAE 10T (37.5)-SAE 10T splined (37.5)		●	●				●
<b>42</b> Scanalato SAEA 11T (55.6)-SAEA 11T splined (55.6)		●	●				●
<b>43</b> Scanalato SAEA 11T (31.5)-SAEA 11T splined (31.5)		●	●				●
<b>44</b> Scanalato SAEA 11T (13.5)-SAEA 11T splined (13.5)						●	
<b>45</b> Scanalato SAEB 13T (41.2)-SAEB 13T splined							◇

◇ = Combinazione standard - Standard combination

● = Combinazione disponibile - Available combination

\* Contattare il Servizio Commerciale. / Available soon. Please contact our Sales Dpt.

**MOTORI AD INGRANAGGI GRUPPO 2SM**  
**GEAR MOTORS GROUP 2SM**

**2SM**

DIMENSIONI ALBERO - SHAFT DIMENSIONS

<p><b>10</b> Conico 1:8 Tapered 1:8</p> <p>Coppia 140 Nm Torque 104 ft-lbs</p>	<p>Disponibile per - available for: <b>EUR- SAEA - SAEAOR - B50C - P400D - SUPEUR</b></p>	<p>Disponibile per - available for: <b>B80C</b></p>
<p><b>11</b> Conico 1:5 Tapered 1:5</p> <p>Coppia 140 Nm Torque 104 ft-lbs</p>	<p>Disponibile per - available for: <b>EUR - SAEA - SAEAOR - B50C</b></p>	<p>Disponibile per - available for: <b>B80C</b></p>
<p><b>12</b> Cilindrico EUR EUR Parall shaft</p> <p>Coppia 80 Nm Torque 59 ft-lbs</p>	<p>Disponibile per - available for: <b>EUR - SAEA - SAEAOR - B50C</b></p>	<p>Disponibile per - available for: <b>B80C</b></p>
<p><b>13</b> Cilindrico SAEA SAEA parall shaft</p> <p>Coppia 90 Nm Torque 67 ft-lbs</p>	<p>Disponibile per - available for: <b>EUR - SAEA - SAEAOR - B50C</b></p>	<p>Disponibile per - available for: <b>B80C</b></p>
<p><b>14</b> Scanalato SAEA 9T SAEA 9T splined</p> <p>Coppia 100 Nm Torque 74 ft-lbs</p>	<p>Disponibile per - available for: <b>EUR - SAEA - SAEAOR - B50C</b></p>	<p>Disponibile per - available for: <b>B80C</b></p>

**MOTORI AD INGRANAGGI GRUPPO 2SM**  
**GEAR MOTORS GROUP 2SM**
**2SM**

## DIMENSIONI ALBERO - SHAFT DIMENSIONS

**15**  
 Scanalato  
 DIN5482 9T  
 (26/24)  
 DIN5482 9T  
 splined (26/24)

Coppia 100 Nm  
 Torque 74 ft-lbs

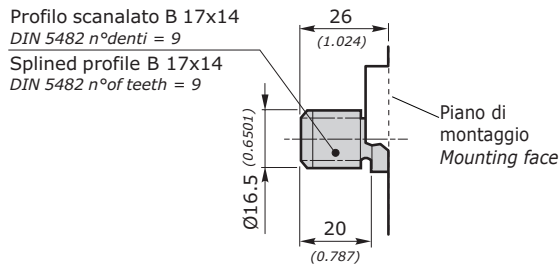

Disponibile per - available for: **EUR - SAEA - SAEAOR - B50C**

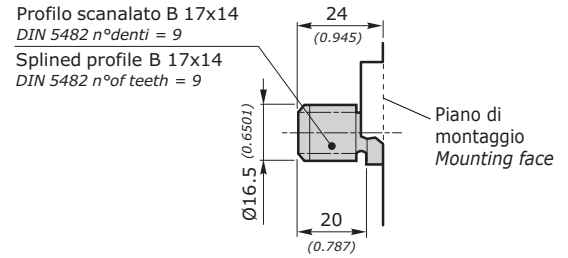

Disponibile per - available for: **B80C**

**16**  
 Scanalato  
 DIN5482  
 9T (20)  
 DIN5482 9T  
 splined (20)

Coppia 100 Nm  
 Torque 74 ft-lbs

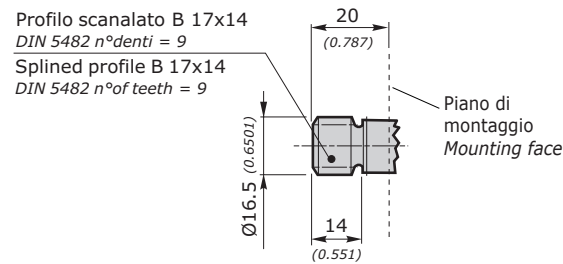

Disponibile per - available for: **EUR - SAEA - SAEAOR - B50C**

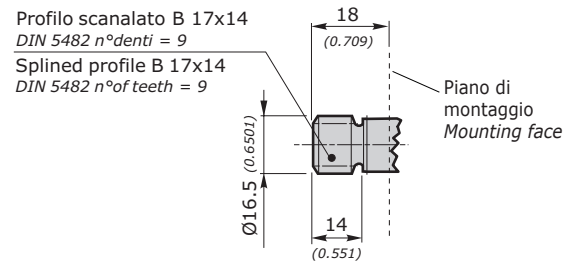

Disponibile per - available for: **B80C**

**17**  
 Fresato a dent  
 frontale  
 Dihedral claw

Coppia 80 Nm  
 Torque 59 ft-lbs

Nota - E' disponibile l'albero senza giunto.  
 Note - Available shaft without coupling.

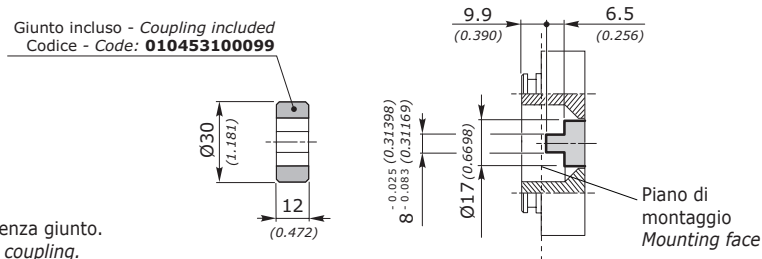

Disponibile per - available for: **E52C**

**40**  
 Scanalato SAE  
 10 T (52)  
 SAE 10T  
 splined (52)

Coppia 130 Nm  
 Torque 96 ft-lbs

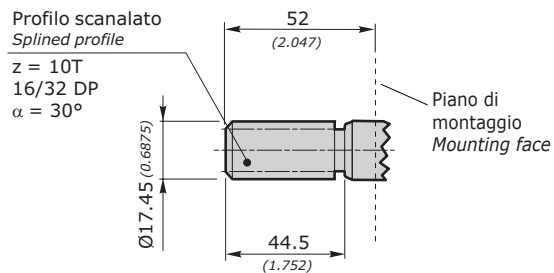

Disponibile per - available for: **SAEA - SAEAOR**

**41**  
 Scanalato SAE  
 10T (37.5)  
 SAE 10T  
 splined (37.5)

Coppia 130 Nm  
 Torque 96 ft-lbs

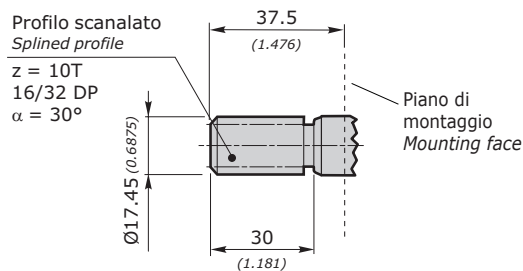

Disponibile per - available for: **SAEA - SAEAOR**



**MOTORI AD INGRANAGGI GRUPPO 2SM**  
**GEAR MOTORS GROUP 2SM**

**2SM**

DIMENSIONI ALBERO - SHAFT DIMENSIONS

**42**  
 Scanalato SAEA  
 11T (55.6)  
 SAEA 11T  
 splined (55.6)

Coppia 150 Nm  
 Torque 111 ft-lbs

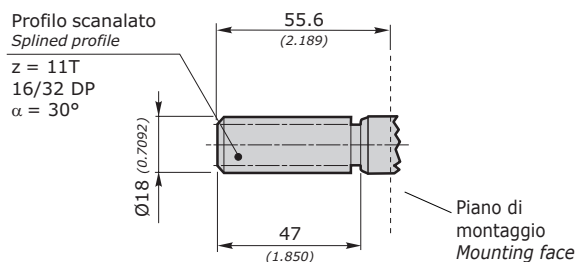

Disponibile per - available for: **SAEA - SAEAOR**

**43**  
 Scanalato SAEA  
 11T (31.5)  
 SAEA 11T  
 splined (31.5)

Coppia 150 Nm  
 Torque 111 ft-lbs

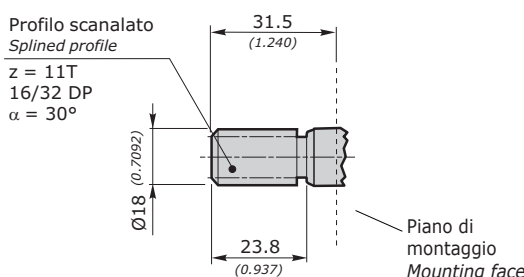

Disponibile per - available for: **SAEA - SAEAOR**

**44**  
 Scanalato SAEB  
 11T (13.5)  
 SAEA 11T  
 splined (13.5)

Coppia 150 Nm  
 Torque 111 ft-lbs

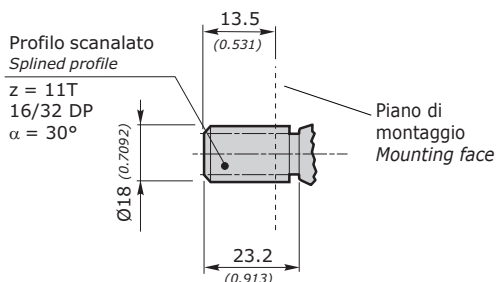

Disponibile per - available for: **E52C**

**45**  
 Scanalato SAEB  
 13T (41.2)  
 SAEB 13T  
 splined (41.2)

Coppia 280 Nm  
 Torque 207 ft-lbs

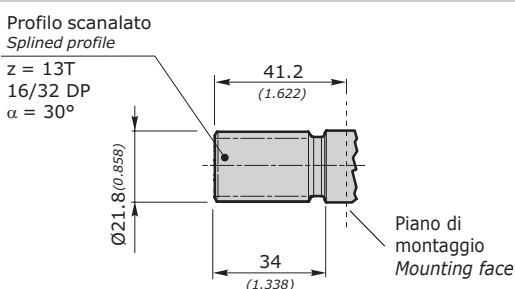

Disponibile per - available for: **SAEB**

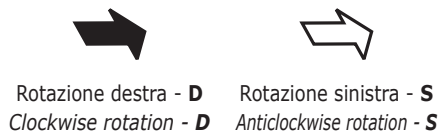
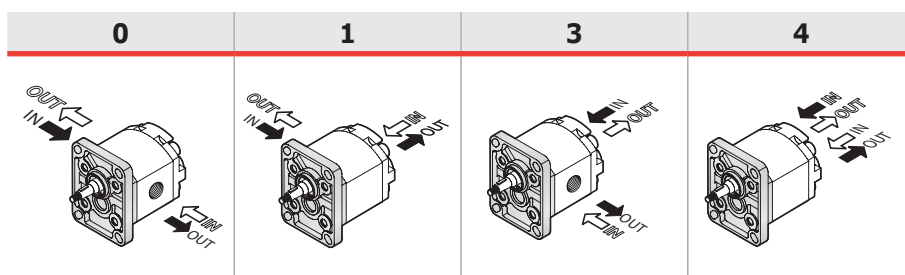
**MOTORI AD INGRANAGGI GRUPPO 2SM**  
**GEAR MOTORS GROUP 2SM**
**POSIZIONE CONNESSIONE PER MOTORI (D-S) • CONNECTION POSITION FOR (D-S) MOTORS**

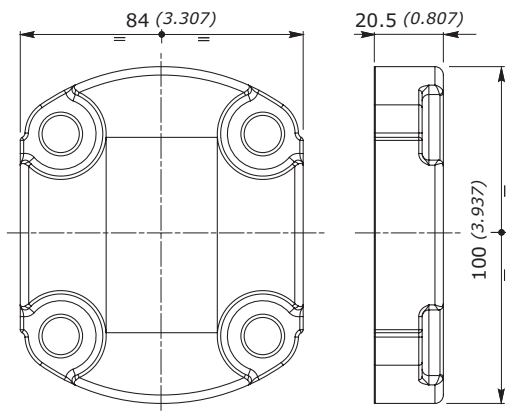
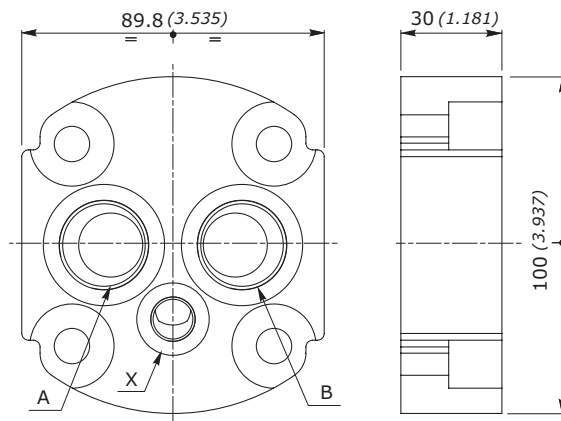
**POSIZIONE CONNESSIONE PER MOTORI (R) • CONNECTION POSITION FOR (R) MOTORS**

**COPERCHIO STANDARD • STANDARD COVER**

 Per posizione **0**  
 For position **0**

 Per posizioni **1, 3, 4**  
 For position **1, 3, 4**

CONNESSIONI / CONNECTION			
	A	B	X
<b>GAS</b>	G 3/4	G 3/4	G 1/4
<b>SAE</b>	SAE 12	SAE 12	SAE 6

**MOTORI AD INGRANAGGI GRUPPO 2SM**  
**GEAR MOTORS GROUP 2SM**

**TIPO CONNESSIONE PER MOTORI D-S • CONNECTION TYPE FOR D-S MOTORS**

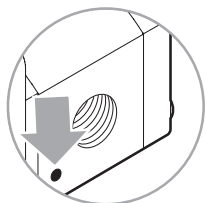
Le connessioni rappresentate corrispondono alle versioni standard; per connessioni differenti, contattare il nostro Ufficio Commerciale. *The connection types shown correspond to standard configurations; for different applications contact our Commercial Dept.*



Il segno del corpo indica il LATO SCARICO per i motori  
*The sign on the body identifies the OUTLET SIDE for the motors*



**IN = INGRESSO - INLET**  
**OUT = SCARICO - OUTLET**

2SM		POSIZIONE CONNESSIONE - CONNECTION POSITION				
		0	1	3	4	DRENAGGIO DRAIN
GAS	<b>G</b>	◇	◇	◇	◇	◇
UNF	<b>U</b>	◇	◇	◇	◇	◇
	<b>W</b>	◇				
FLANGIATE FLANGED	<b>T</b>	◇				
	<b>N</b>	◇				
	<b>M</b>	◇				
	<b>F</b>	◇				

GAS	UNI ISO 228/1	SIGLA CODE	CIL. DISPL.	SCARICO - OUTLET OUT			INGRESSO - INLET IN		
				A	B	↻	A	B	↻
		<b>G</b>	40	G 1/2"	16 [mm] 0.630 [inch]	50 [Nm] 443 [in.lbs]	G 1/2"	16 [mm] 0.630 [inch]	50 [Nm] 443 [in.lbs]
			60						
			80						
			110	G 3/4"	17 [mm] 0.670 [inch]	60 [Nm] 531 [in.lbs]			
			140						
			160						
			190						
			220						
			260						
			310						

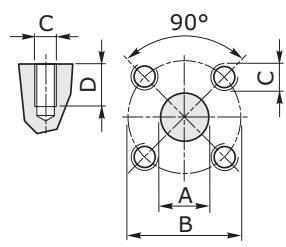
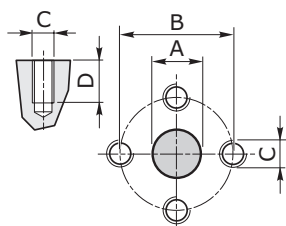
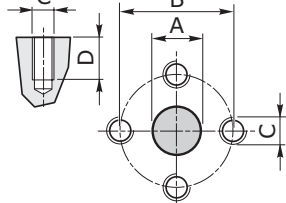

UNF	ANSI/ASME B1.1	SIGLA CODE	CIL. DISPL.	SCARICO - OUTLET OUT			INGRESSO - INLET IN		
				A	B	↻	A	B	↻
		<b>U</b>	40	SAE 10 7/8"-14 UNF	17 [mm] 0.670 [inch]	55 [Nm] 487 [in.lbs]	SAE 10 7/8"-14 UNF	17 [mm] 0.670 [inch]	55 [Nm] 487 [in.lbs]
			60						
			80						
			110	SAE 12 1"1/16-12 UN	20 [mm] 0.788 [inch]	60 [Nm] 531 [in.lbs]			
			140						
			160						
			190						
			220						
			260						
			310						
			40	SAE 16 1"5/16-12 UN	20 [mm] 0.788 [inch]	70 [Nm] 620 [in.lbs]	SAE 12 1"1/16-12 UN	20 [mm] 0.788 [inch]	60 [Nm] 531 [in.lbs]
			60						
			80						
			110						
140									
160									
190									
220									
260									
310									

**MOTORI AD INGRANAGGI GRUPPO 2SM**  
**GEAR MOTORS GROUP 2SM**

FLANGIATE FLANGED	ISO/R 262	SIGLA CODE	CIL. DISPL.	SCARICO - OUTLET OUT					INGRESSO - INLET IN						
				A	B	C	D		A	B	C	D			
		T	40												
			60												
			80												
			110	20	40		15	8	15	35		15	8		
			140	[mm]	[mm]	M6	[mm]	[Nm]	[mm]	[mm]	M6	[mm]	[Nm]		
			160	0.787	1.575		0.591	71	0.591	1.378		0.591	71		
			190	[inch]	[inch]		[inch]	[in.lbs]	[inch]	[inch]		[inch]	[in.lbs]		
			220												
			260												
			310												
		N	40	13	30		15	8							
			60	[mm]	[mm]	M6	[mm]	[Nm]							
			80	0.512	1.181		0.591	71							
			110						13	30		15	8		
			140						[mm]	[mm]	M6	[mm]	[Nm]		
			160	19	40		14	15	0.512	1.181		0.591	71		
			190	[mm]	[mm]	M8	[mm]	[Nm]	[inch]	[inch]		[inch]	[in.lbs]		
			220	0.748	1.575		0.552	133				0.552	133		
			260	[inch]	[inch]		[inch]	[in.lbs]				[inch]	[in.lbs]		
			310												
		M	40	non disponibile not available					non disponibile not available						
			60												
			80												
			110												
			140												
			160	19	40		14	15	19	40		14	15		
			190	[mm]	[mm]	M8	[mm]	[Nm]	[mm]	[mm]	M8	[mm]	[Nm]		
			220	0.748	1.575		0.552	133	0.748	1.575		0.552	133		
			260	[inch]	[inch]		[inch]	[in.lbs]	[inch]	[inch]		[inch]	[in.lbs]		
			310												

Standard Galtech

Galtech standard

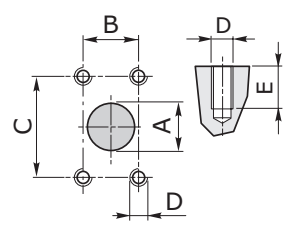
FLANGIATE FLANGED	ISO/R 262	SIGLA CODE	CIL. DISPL.	SCARICO - OUTLET OUT					INGRESSO - INLET IN						
				A	B	C	D	E		A	B	C	D	E	
		F	40	20	17,4	38		15	8						
			60	[mm]	[mm]	[mm]	M6	[mm]	[Nm]						
			80	0.787	0.685	1.496		0.591	71						
			110	[inch]	[inch]	[inch]		[inch]	[in.lbs]						
			140							15	17,4	38		15	8
			160							[mm]	[mm]	[mm]	M6	[mm]	[Nm]
			190	26	47.6	22.4		15	8	0.591	0.685	1.496		0.591	71
			220	[mm]	[mm]	[mm]	M6	[mm]	[Nm]	[inch]	[inch]	[inch]		[inch]	[in.lbs]
			260	1.024	1.874	0.882		0.591	71					0.591	71
			310	[inch]	[inch]	[inch]		[inch]	[in.lbs]					[inch]	[in.lbs]

**MOTORI AD INGRANAGGI GRUPPO 2SM**  
**GEAR MOTORS GROUP 2SM**

**TIPO CONNESSIONE PER MOTORI (R) • CONNECTION TYPE FOR (R) MOTORS**

Le connessioni rappresentate corrispondono alle versioni standard; *The connection types shown correspond to standard configurations; for different applications contact our Commercial Dept.*  
 per connessioni differenti, contattare il nostro Ufficio Commerciale.

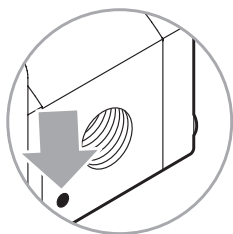

L'eventuale segno sul corpo dei Motori REVERSIBILI non è da considerare.  
*Any sign on the body of REVERSIBLE Motors has not to be considered.*

**IN = INGRESSO - INLET**  
**OUT = SCARICO - OUTLET**

GAS	<b>G</b>	◇	◇	◇	◇
UNF	<b>U</b>	◇	◇	◇	◇
FLANGIATE FLANGED	<b>T</b>	◇			
	<b>N</b>	◇			
	<b>F</b>	◇			

GAS	UNI ISO 228/1	SIGLA CODE	CIL. DISPL.	SCARICO - OUTLET OUT			INGRESSO - INLET IN		
				A	B	↺	A	B	↺
	G		40	G 1/2"	16 [mm] 0.630 [inch]	50 [Nm] 443 [in.lbs]	G 1/2"	16 [mm] 0.630 [inch]	50 [Nm] 443 [in.lbs]
			60						
			80						
			110	G 3/4"	17 [mm] 0.670 [inch]	60 [Nm] 531 [in.lbs]	G 3/4"	17 [mm] 0.670 [inch]	60 [Nm] 531 [in.lbs]
			140						
			160						
			190						
			220						
			260						
			310						

UNF	ANSI/ASME B1.1	SIGLA CODE	CIL. DISPL.	SCARICO - OUTLET OUT			INGRESSO - INLET IN		
				A	B	↺	A	B	↺
	U		40	SAE 10 7/8"-14 UNF	17 [mm] 0.670 [inch]	55 [Nm] 487 [in.lbs]	SAE 10 7/8"-14 UNF	17 [mm] 0.670 [inch]	55 [Nm] 487 [in.lbs]
			60						
			80						
			110	SAE 12 1 1/16-12 UN	20 [mm] 0.788 [inch]	60 [Nm] 531 [in.lbs]	SAE 12 1 1/16-12 UN	20 [mm] 0.788 [inch]	60 [Nm] 531 [in.lbs]
			140						
			160						
			190						
			220						
			260						
			310						

**MOTORI AD INGRANAGGI GRUPPO 2SM**  
**GEAR MOTORS GROUP 2SM**

FLANGIATE FLANGED	ISO/R 262	SIGLA CODE	CIL. DISPL.	SCARICO - OUTLET OUT					INGRESSO - INLET IN					
				A	B	C	D		A	B	C	D		
	T		40	15 [mm]	35 [mm]	M6	15 [mm]	8 [Nm]	15 [mm]	35 [mm]	M6	15 [mm]	8 [Nm]	
			60	0.591 [inch]	1.378 [inch]		0.591 [inch]	71 [in.lbs]	0.591 [inch]	1.378 [inch]		0.591 [inch]	71 [in.lbs]	
			80											
			110											
			140											
			160	20 [mm]	40 [mm]	M6	15 [mm]	8 [Nm]	20 [mm]	40 [mm]	M6	15 [mm]	8 [Nm]	
			190	0.787 [inch]	1.575 [inch]		0.591 [inch]	71 [in.lbs]	0.787 [inch]	1.575 [inch]		0.591 [inch]	71 [in.lbs]	
			220											
			260											
			310											
	N		40	13 [mm]	30 [mm]	M6	15 [mm]	8 [Nm]	13 [mm]	30 [mm]	M6	15 [mm]	8 [Nm]	
			60	0.512 [inch]	1.181 [inch]		0.591 [inch]	71 [in.lbs]	0.512 [inch]	1.181 [inch]		0.591 [inch]	71 [in.lbs]	
			80											
			110											
			140											
			160	19 [mm]	40 [mm]	M8	14 [mm]	15 [Nm]	19 [mm]	40 [mm]	M8	14 [mm]	15 [Nm]	
			190	0.748 [inch]	1.575 [inch]		0.552 [inch]	133 [in.lbs]	0.748 [inch]	1.575 [inch]		0.552 [inch]	133 [in.lbs]	
			220											
			260											
			310											

Standard Galtech

Galtech standard

FLANGIATE FLANGED	ISO/R 262	SIGLA CODE	CIL. DISPL.	SCARICO - OUTLET OUT					INGRESSO - INLET IN						
				A	B	C	D	E		A	B	C	D	E	
	F*		40	20 [mm]	17,4 [mm]	38 [mm]	M6	15 [mm]	8 [Nm]	20 [mm]	17,4 [mm]	38 [mm]	M6	15 [mm]	8 [Nm]
			60	0.787 [inch]	0.685 [inch]	1.496 [inch]		0.591 [inch]	71 [in.lbs]	0.787 [inch]	0.685 [inch]	1.496 [inch]		0.591 [inch]	71 [in.lbs]
			80												
			110												
			140												
			160	26 [mm]	22.4 [mm]	47.6 [mm]	M6	15 [mm]	8 [Nm]	26 [mm]	47.6 [mm]	22.4 [mm]	M6	15 [mm]	8 [Nm]
			190	1.024 [inch]	0.882 [inch]	1.874 [inch]		0.591 [inch]	71 [in.lbs]	1.024 [inch]	1.874 [inch]	0.882 [inch]		0.591 [inch]	71 [in.lbs]
			220												
			260												
			310												

\*: Le flange non corrispondono a norma SAEJ518. Flange a norma disponibili a richiesta, contattare il Servizio Commerciale.

\*: Flanges F do not correspond to SAEJ518. Flanges SAEJ518 available on request, please contact our Sales Dpt.

**MOTORI AD INGRANAGGI GRUPPO 2SM**  
**GEAR MOTORS GROUP 2SM**

**VLP**

MOTORE UNIDIREZIONALE A 2 VELOCITÀ CON VALVOLA LIMITATRICE DI PRESSIONE  
 2 SPEED UNIDIRECTIONAL MOTOR WITH PRESSURE RELIEF VALVE

Solo per motori con flangia e coperchio in alluminio. *Only for motors with aluminium flange and cover.*

ROTAZIONE DESTRA - CLOCKWISE ROTATION

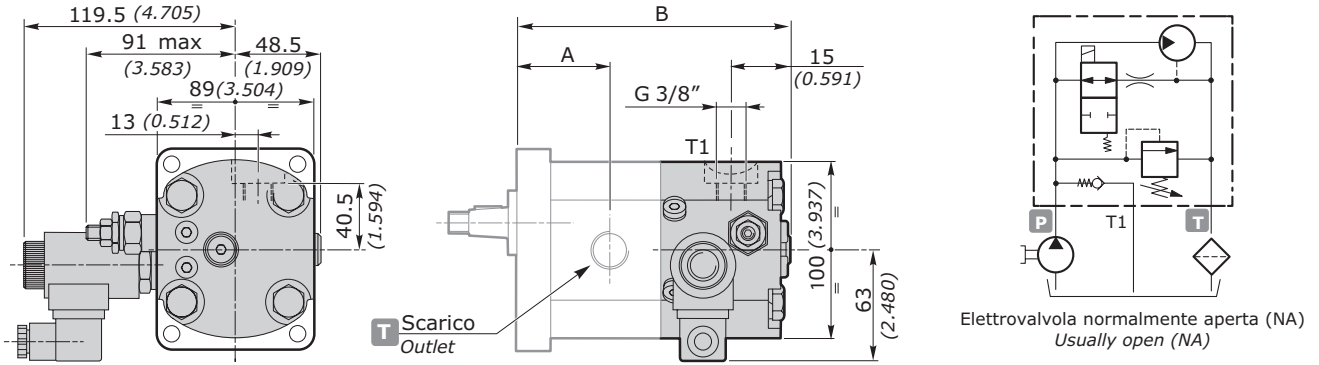

ROTAZIONE SINISTRA - ANTICLOCKWISE ROTATION

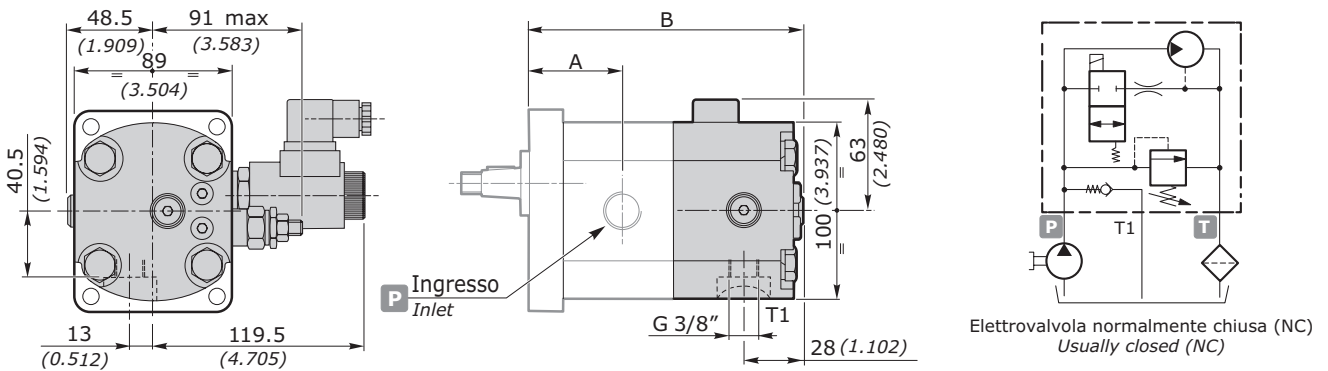

A	mm	44.4	46.0	48.1	50.2	52.7	54.8	57.3	59.8	62.7	66.9
	inch	1.748	1.811	1.894	1.976	2.075	2.157	2.256	2.354	2.469	2.636
B	mm	142.3	145.6	149.8	153.9	158.9	163.1	168.1	173.1	182.0	190.4
	inch	5.602	5.732	5.898	6.059	6.256	6.421	6.618	6.815	7.165	7.502

esempio • example: **2SM - A - 080 - D - EUR - H - N - 10 - 0 - N - NA 24VDC VLP (N 150)**

- NA** = Normalmente aperta / *Usually open*    **NC** = Normalmente chiusa / *Usually closed*
- 24VDC** = Tensione magnete / *Electromagnete voltage* (12VDC - 24VDC - 48VDC)
- VLP** = Coperchio con VPL / *Cover with VPL*
- N** = Tipo molla - vedi tabella / *Spring type - see table*
- 150** = Taratura - vedi tabella / *Setting - see table*

TIPO - TYPE	CAMPI DI TARATURE - CALIBRATION FIELDS					
	molla bianca - white spring	B	molla nera - black spring	N	molla rossa - red spring	R
bar	30 ÷ 80		81 ÷ 200		201 ÷ 350	
psi	435 ÷ 1160		1175 ÷ 2900		2915 ÷ 5075	
STANDARD	70 bar (1015 psi)		150 bar (2175 psi)		250 bar (3625 psi)	

NOTA: In caso di omissione del valore di taratura, esso sarà inteso standard (vedi tabella).  
 NOTE: Without setting request, it will be considered standard (see table).

**MOTORI AD INGRANAGGI GRUPPO 2SM**  
**GEAR MOTORS GROUP 2SM**
**OPZIONI • OPTIONS**
**VLPI**

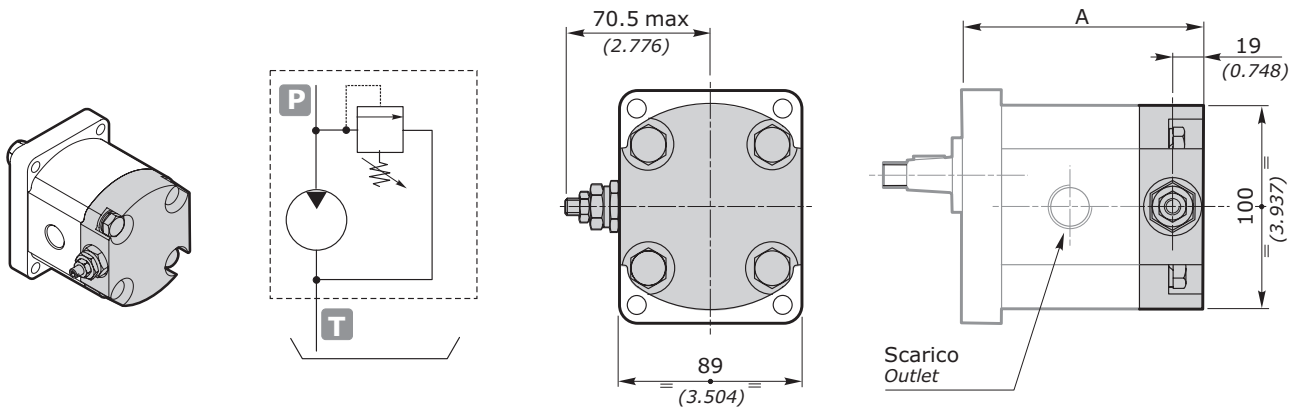
 VALVOLA LIMITATRICE DI PRESSIONE A SCARICO INTERNO  
 PRESSURE RELIEF VALVE WITH INTERNAL EXHAUST

GRUPPO GROUP 2	EUR-SAEA-B50C		A B80C		E52C	
	mm	inch	mm	inch	mm	inch
<b>2SM 040</b>	104.8	4.126	106.8	4.205	102.1	4.020
<b>2SM 060</b>	108.1	4.256	110.1	4.335	105.4	4.150
<b>2SM 080</b>	112.3	4.421	114.3	4.500	109.6	4.315
<b>2SM 110</b>	116.4	4.583	118.4	4.661	113.7	4.476
<b>2SM 140</b>	121.4	4.780	123.4	4.858	118.7	4.673
<b>2SM 160</b>	125.6	4.945	127.6	5.024	122.9	4.839
<b>2SM 190</b>	130.6	5.142	132.6	5.220	127.9	5.035
<b>2SM 220</b>	135.6	5.339	137.6	5.417	132.9	5.232
<b>2SM 260</b>	141.4	5.567	143.4	5.646	138.7	5.461
<b>2SM 310</b>	149.8	5.902	151.8	5.981	147.1	5.796

La valvola limitatrice di pressione si applica sostituendo il coperchio posteriore. Il coperchio VLP è disponibile in alluminio. E' rappresentato un motore con rotazione destra. Nei motori con rotazione sinistra, la valvola è nel lato opposto.

*The pressure relief valve can be applied by replacing the rear cover. VLP cover is available in aluminum. The motor shown here is clockwise rotation. In case of Motor with anticlockwise rotation, the valve is on the opposite side.*

 esempio • example: **2SM - A - 140 - D - EUR - H - N - 10 - 0 - G - VLPI (N 120)**
**VLPI** = Coperchio con VPL a scarico interno / Cover with VPL with internal exhaust

**N** = Tipo molla - vedi tabella / Spring type - see table

**120** = Taratura - vedi tabella / Setting - see table

TIPO - TYPE	CAMPI DI TARATURE - CALIBRATION FIELDS					
	molla bianca - white spring	B	molla nera - black spring	N	molla rossa - red spring	R
bar	30 ÷ 80		81 ÷ 200		201 ÷ 350	
psi	435 ÷ 1160		1175 ÷ 2900		2915 ÷ 5075	
STANDARD	70 bar (1015 psi)		150 bar (2175 psi)		250 bar (3625 psi)	

NOTA: In caso di omissione del valore di taratura, esso sarà inteso standard (vedi tabella).

NOTE: Without setting request, it will be considered standard (see table).



**MOTORI AD INGRANAGGI GRUPPO 2SM**  
**GEAR MOTORS GROUP 2SM**

**VLPE**

VALVOLA LIMITATRICE DI PRESSIONE A SCARICO ESTERNO  
 PRESSURE RELIEF VALVE WITH EXTERNAL EXHAUST

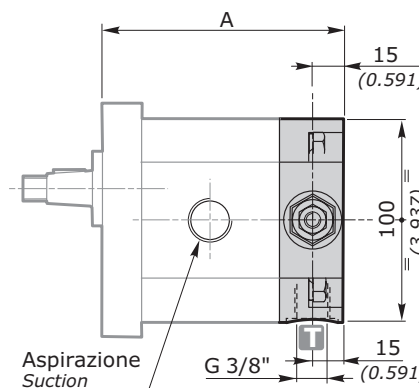
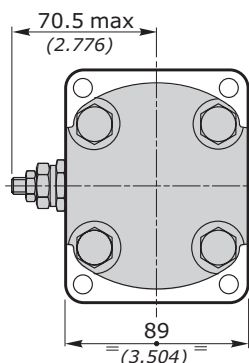
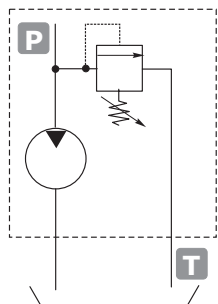
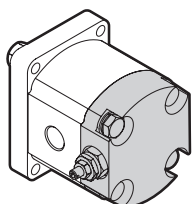

GRUPPO GROUP 2	EUR-SAEA-B50C		A B80C		E52C	
	mm	inch	mm	inch	mm	inch
2SM 040	100.8	3.969	102.8	4.047	98.1	3.862
2SM 060	104.1	4.098	106.1	4.177	101.4	3.992
2SM 080	108.3	4.264	110.3	4.343	105.6	4.157
2SM 110	112.4	4.425	114.4	4.504	109.7	4.319
2SM 140	117.4	4.622	119.4	4.701	114.7	4.516
2SM 160	121.6	4.787	123.6	4.866	118.9	4.681
2SM 190	126.6	4.984	128.6	5.063	123.9	4.878
2SM 220	131.6	5.181	133.6	5.260	128.9	5.075
2SM 260	137.4	5.409	139.4	5.488	134.7	5.303
2SM 310	145.8	5.745	147.8	5.823	143.1	5.638

La valvola limitatrice di pressione si applica sostituendo il coperchio posteriore. Il coperchio VLP è disponibile in alluminio. E' rappresentato un motore con rotazione destra. Nei motori con rotazione sinistra, la valvola è dal lato opposto

*The pressure relief valve can be applied by substituting the rear cover. VLP cover is available in aluminum. The showed motor is with clockwise rotation. In the case of motors with anticlockwise rotation, the valve is on the opposite side.*

esempio • example: **2SM - A - 140 - D - EUR - H - N - 10 - 0 - G - VLPE (N 120)**

**VLPE** = Coperchio con VPL a scarico esterno / Cover with VPL with external exhaust

**N** = Tipo molla - vedi tabella / Spring type - see table

**120** = Taratura - vedi tabella / Setting - see table

TIPO - TYPE	CAMPI DI TARATURE - CALIBRATION FIELDS					
	molla bianca - white spring	<b>B</b>	molla nera - black spring	<b>N</b>	molla rossa - red spring	<b>R</b>
bar	30 ÷ 80		81 ÷ 200		201 ÷ 350	
psi	435 ÷ 1160		1175 ÷ 2900		2915 ÷ 5075	
STANDARD	70 bar (1015 psi)		150 bar (2175 psi)		250 bar (3625 psi)	

NOTA: In caso di omissione del valore di taratura, esso sarà inteso standard (vedi tabella).

NOTE: Without setting request, it will be considered standard (see table).

**MOTORI AD INGRANAGGI GRUPPO 2SM**  
**GEAR MOTORS GROUP 2SM**
**UNLD**

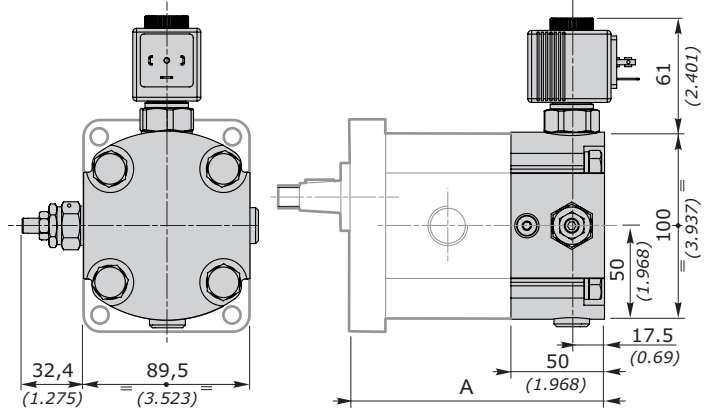
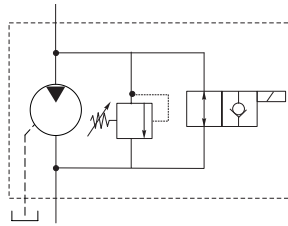
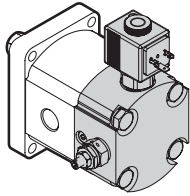
 VALVOLA UNLOADING  
 UNLOADING VALVE

GRUPPO GROUP 2	EUR-SAE B50C		A			
	mm	inch	B80C		E52C	
<b>2SM 040</b>	123.8	4.874	125.8	4.952	121.1	4.767
<b>2SM 060</b>	127.1	5.003	129.1	5.082	124.4	4.897
<b>2SM 080</b>	131.3	5.169	133.3	5.248	128.6	5.062
<b>2SM 110</b>	135.4	5.330	137.4	5.409	132.7	5.224
<b>2SM 140</b>	140.4	5.527	142.4	5.606	137.7	5.421
<b>2SP 160</b>	144.6	5.692	146.6	5.771	141.9	5.586
<b>2SP 190</b>	149.6	5.889	151.6	5.968	146.9	5.793
<b>2SP 220</b>	154.6	6.086	156.6	6.165	151.9	5.980
<b>2SP 260</b>	160.4	6.314	162.4	6.393	157.7	6.208
<b>2SP 310</b>	168.8	6.645	170.8	6.724	166.1	6.539

 esempio • example: **2SM-A-140-D-EUR-H-N-10-0-T-NA(UNLD)-VLPI(N100)-12VDC**
**UNLD** = Coperchio con valvola unloading standard - Standard cover with unloading valve

**N** = Tipo molla - vedi tabella / Spring type - see table

**100** = Taratura - vedi tabella / Setting - see table

TIPO - TYPE	CAMPI DI TARATURE - CALIBRATION FIELDS					
	molla bianca - white spring	B	molla nera - black spring	N	molla rossa - red spring	R
bar	30 ÷ 80		81 ÷ 200		201 ÷ 350	
psi	435 ÷ 1160		1175 ÷ 2900		2915 ÷ 5075	
STANDARD	70 bar (1015 psi)		150 bar (2175 psi)		250 bar (3625 psi)	

NOTA: In caso di omissione del valore di taratura, esso sarà inteso standard (vedi tabella).

NOTE: Without setting request, it will be considered standard (see table).

**MOTORI AD INGRANAGGI GRUPPO 2SM**  
**GEAR MOTORS GROUP 2SM**

**VRFR**

VALVOLA REGOLATRICE DI PORTATA COMPENSATA  
FLOW CONTROL PRESSURE COMPENSATED VALVE

**VRFR35-U(110)**

Fino a 35 lpm controllati in ingresso - inlet control up to 35 lpm

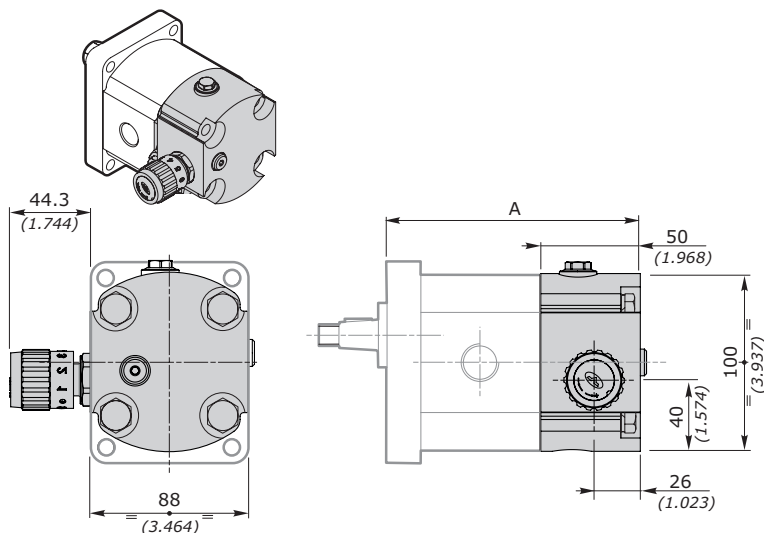

GRUPPO GROUP 2	EUR-SAE-A-B50C		A (PP10) B80C		E52C	
	mm	inch	mm	inch	mm	inch
2SM 040	127.8	5.031	129.8	5.110	125.1	4.925
2SM 060	131.1	5.161	133.1	5.240	128.4	5.055
2SM 080	135.3	5.326	137.3	5.405	132.6	5.220
2SM 110	139.4	5.488	141.4	5.566	136.7	5.381
2SM 140	144.4	5.685	146.4	5.763	141.7	5.578
2SM 160	148.6	5.850	150.6	5.929	145.9	5.744
2SM 190	153.6	6.047	155.6	6.125	150.9	5.940
2SM 220	158.6	6.244	160.6	6.322	155.9	6.137
2SM 260	164.4	6.472	166.4	6.551	161.7	6.366
2SM 310	172.8	6.803	174.8	6.881	170.1	6.696

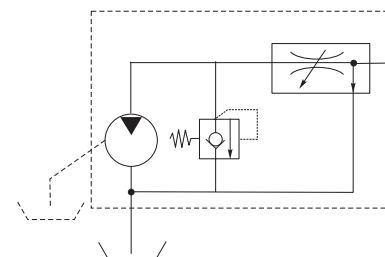

**VRFR55-U(110)**

Fino a 55 lpm controllati in ingresso - inlet control up to 55 lpm

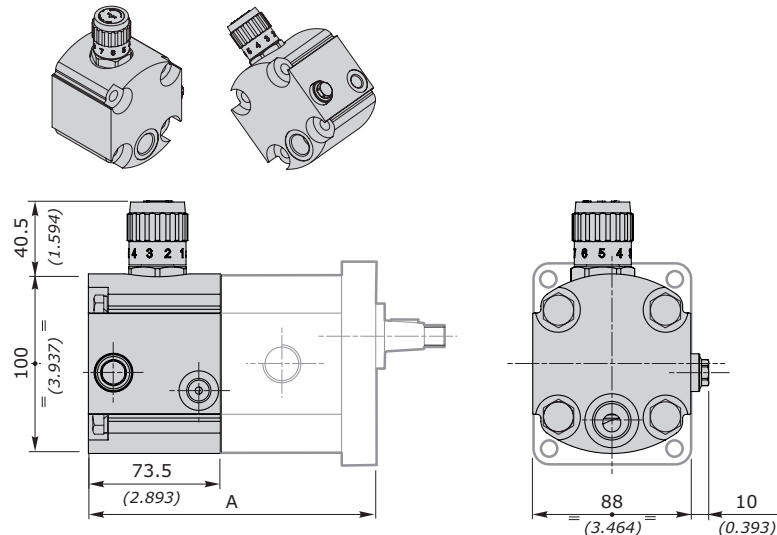

GRUPPO GROUP 2	EUR-SAE-A-B50C		A (PP12) B80C		E52C	
	mm	inch	mm	inch	mm	inch
2SM 040	151.3	5.956	153.3	6.035	148.6	5.850
2SM 060	154.6	6.086	156.6	6.165	151.9	5.980
2SM 080	158.8	6.251	160.8	6.330	156.1	6.145
2SM 110	162.9	6.413	164.9	6.492	160.2	6.307
2SM 140	167.9	6.610	169.9	6.688	165.2	6.503
2SM 160	172.1	6.775	174.1	6.854	169.4	6.669
2SM 190	177.1	6.972	179.1	7.051	174.4	6.866
2SM 220	182.1	7.169	184.1	7.248	179.4	7.062
2SM 260	187.9	7.397	189.9	7.476	185.2	7.291
2SM 310	196.3	7.728	198.3	7.807	193.6	7.622

esempio • example: **2SM - A - 140 - D - EUR - H - N - 10 - 0 - N - VRFR55 - U(110)**

**VRFR55** = Coperchio con valvola regolatrice di portata / Cover with flow control pressure compensated valve

**110** = Taratura - vedi tabella / Setting - see table

**VALVOLE ANTICAVITAZIONE A TARATURA FISSA - FIXED SETTING ANTICAVITATION VALVES**

bar	50	63	80	100	110	125	140	150	160	175	190	200	210	230	240	250
psi	725	914	1150	1450	1590	1800	2050	2150	2300	2550	2750	2900	3050	3350	3500	3600

NOTE: La valvola VLPI va ordinata separatamente.

In caso si omissione del valore di taratura, esso sarà inteso standard.

NOTES: VLPI valve must be ordered separately. Without setting request, it will be considered standard.

**MOTORI AD INGRANAGGI GRUPPO 2SM**  
**GEAR MOTORS GROUP 2SM**
**VA**

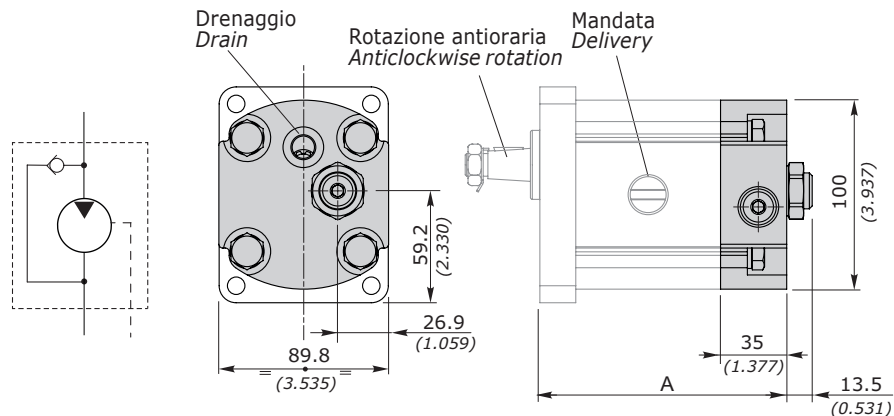
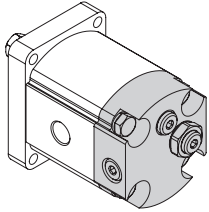
 VALVOLA ANTICAVITAZIONE  
 ANTICAVITATION VALVE

GRUPPO GROUP 2	EUR-SAE-A-B50C		A B80C		E52C	
	mm	inch	mm	inch	mm	inch
<b>2SM 040</b>	109.3	4.303	111.3	4.381	106.6	4.196
<b>2SM 060</b>	112.6	4.433	114.6	4.511	109.9	4.326
<b>2SM 080</b>	116.8	4.598	118.8	4.677	114.1	4.492
<b>2SM 110</b>	120.9	4.759	122.9	4.838	118.2	4.653
<b>2SM 140</b>	125.9	4.956	127.9	5.035	123.2	4.850
<b>2SM 160</b>	130.1	5.122	132.1	5.200	127.4	5.015
<b>2SM 190</b>	135.1	5.318	137.1	5.397	132.4	5.212
<b>2SM 220</b>	140.1	5.515	142.1	5.594	137.4	5.409
<b>2SM 260</b>	145.9	5.744	147.9	5.822	143.2	5.637
<b>2SM 310</b>	154.3	6.074	156.3	6.153	151.6	5.968

esempio • example:

**2SM - A - 110 - S - EUR - H - N - 10 - 0 - G - VA**
**D** = Rotazione destra / Clockwise rotation

**S** = Rotazione sinistra / Anticlockwise rotation

**D(R)** = Reversibile, montata unidirezionale e valvola come motore destro  
 Reversible, mounted as clockwise rotation and valve as right gear motor

**S(R)** = Reversibile, montata unidirezionale e valvola come motore sinistro  
 Reversible, mounted as anticlockwise rotation and valve as left gear motor

**R...VA(D)/VA(S)** = Reversibile / Reversible

**VA** = Coperchio con valvola anticavitazione / Cover with anticavitation valve

**R...VA(D)** = Valvola montata come motore destro / Valve mounted as right gear motor

**R...VA(S)** = Valvola montata come motore sinistro / Valve mounted as left gear motor

NOTA: Nell'esempio viene descritto un motore a rotazione sinistra con valvola anticavitazione montata come motore sinistro, per altre configurazioni contattare il Servizio Commerciale

NOTE: in the example is represented gear motor with anticlockwise rotation and anticavitation valve mounted as left gear motor. For other configurations please contact our Sales Dpt.

**MOTORI AD INGRANAGGI GRUPPO 2SM**  
**GEAR MOTORS GROUP 2SM**

**VMA**

VALVOLA ANTICAVITAZIONE E ANTIURTO  
 ANTICAVITATION AND ANTISHOCK VALVE

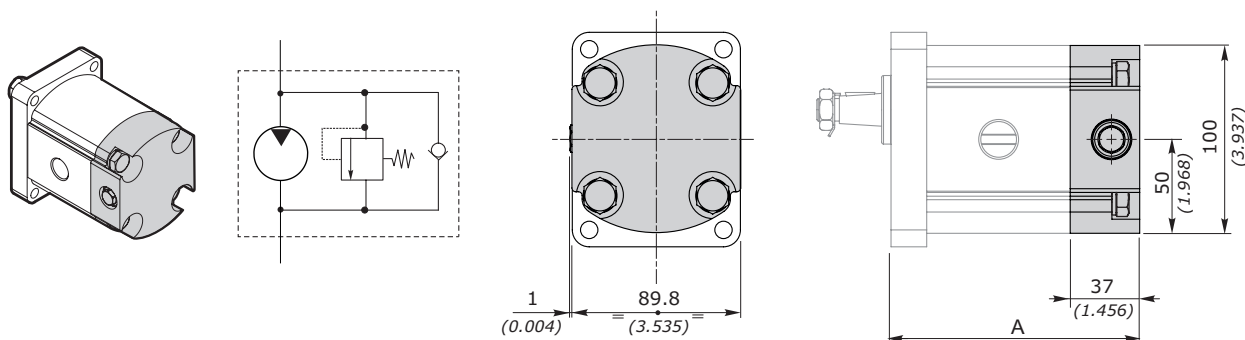

GRUPPO GROUP 2	EUR-SAE-A-B50C		A B80C		E52C	
	mm	inch	mm	inch	mm	inch
<b>2SP 040</b>	111.3	4.381	113.3	4.450	108.6	4.275
<b>2SP 060</b>	114.6	4.511	116.6	4.590	111.9	4.405
<b>2SP 080</b>	118.8	4.677	120.8	4.755	116.1	4.570
<b>2SP 110</b>	122.9	4.838	124.9	4.917	120.2	4.732
<b>2SP 140</b>	127.9	5.035	129.9	5.114	125.2	4.929
<b>2SP 160</b>	132.1	5.200	134.1	5.279	129.4	5.094
<b>2SP 190</b>	137.1	5.397	139.1	5.476	134.4	5.291
<b>2SP 220</b>	142.1	5.594	144.1	5.673	139.4	5.488
<b>2SP 260</b>	147.9	5.822	149.9	5.901	145.2	5.716
<b>2SP 310</b>	156.3	6.153	158.3	6.232	153.6	6.047

esempio • example: **2SM - A - 140 - D - EUR - H - N - 10 - 0 - G - VMA**

**VMA** = Coperchio con valvola anticavitazione / Cover with anticavitation valve

**VALVOLE ANTICAVITAZIONE A TARATURA FISSA - FIXED SETTING ANTICAVITATION VALVES**

bar	50	63	80	100	110	125	140	150	160	175	190	200	210	230	240	250
psi	725	914	1150	1450	1590	1800	2050	2150	2300	2550	2750	2900	3050	3350	3500	3600

NOTA: In caso di omissione del valore di taratura, esso sarà inteso standard.

NOTE: Without setting request, it will be considered standard.

**MOTORI AD INGRANAGGI GRUPPO 3GM**  
**GEAR MOTORS GROUP 3GM**
**FLANGIA EUROPEA EUR EUROPEAN FLANGE**
**FLANGIA E COPERCHIO IN GHISA - CAST IRON FLANGE AND COVER**

GRUPPO GROUP 3GM	CILINDRATA DISPLACEMENT		PRESSIONE MAX - MAX PRESSURE								VELOCITÀ MAX MAX SPEED	PORTATA MAX MAX FLOW		VELOCITÀ MIN MIN SPEED	
	cm <sup>3</sup> /giro	in <sup>3</sup> /rev	S - D		R		S - D		R			l/min	Gal/min		giri/min - rpm
			P1 bar	P1 psi	P1 bar	P1 psi	P2 bar	P2 psi	P2 bar	P2 psi					
<b>3GM 190</b>	19.3	1.2	250	3625	215	3117	265	3842	230	3335	3500	67.6	17.84	600	
<b>3GM 230</b>	23.0	1.4	250	3625	215	3117	265	3842	230	3335	3500	80.3	21.22	600	
<b>3GM 300</b>	30.2	1.8	240	3480	205	2972	255	3621	220	3190	3300	99.7	26.33	600	
<b>3GM 340</b>	33.8	2.1	240	3480	205	2972	255	3621	220	3190	3300	111.6	29.49	600	
<b>3GM 370</b>	37.5	2.3	230	3335	195	2827	245	3552	210	3045	3300	123.6	32.66	600	
<b>3GM 440</b>	44.6	2.7	220	3190	190	2755	235	3407	205	2972	3000	133.8	35.35	600	
<b>3GM 530</b>	53.0	3.2	210	3045	180	2610	225	3262	195	2827	3000	159.1	42.04	600	
<b>3GM 620</b>	62.7	3.8	190	2755	160	2320	200	2900	170	2465	2500	156.8	41.41	600	
<b>3GM 700</b>	70.5	4.3	180	2610	155	2247	190	2755	165	2392	2500	176.3	46.58	600	
<b>3GM 770</b>	77.2	4.7	170	2465	145	2102	180	2610	155	2247	2200	169.8	44.84	600	

Nota - Per valori di pressione superiori a quelli indicati contattare il Servizio Commerciale.  
 Note - for higher pressure values please contact our Sales Dpt.

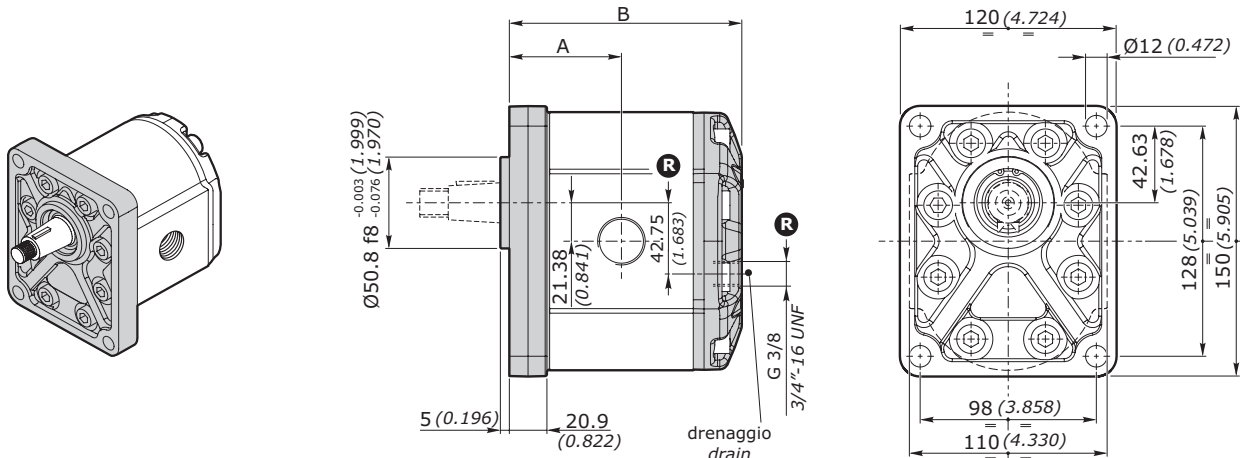
**DIMENSIONI • DIMENSIONS**

**R** Solo per motori reversibili - Only for reversible motors

GRUPPO - GROUP 3	A		B		MASSA - MASS	
	mm	inch	mm	inch	kg	lbs
<b>3GM 190</b>	62.4	2.456	128.3	5.051	7.67	16.91
<b>3GM 230</b>	63.9	2.515	131.3	5.169	7.81	17.21
<b>3GM 300</b>	66.9	2.633	137.3	5.405	8.09	17.82
<b>3GM 340</b>	68.4	2.692	140.3	5.523	8.22	18.12
<b>3GM 370</b>	69.9	2.751	143.3	5.641	8.36	18.43
<b>3GM 440</b>	72.9	2.870	149.3	5.877	8.64	19.04
<b>3GM 530</b>	76.4	3.007	156.3	6.153	8.96	19.75
<b>3GM 620</b>	80.4	3.165	164.3	6.468	9.33	20.56
<b>3GM 700</b>	86.9	3.421	170.8	6.724	9.63	21.22
<b>3GM 770</b>	92.4	3.637	176.3	6.940	9.88	21.77

**MOTORI AD INGRANAGGI GRUPPO 3GM**  
**GEAR MOTORS GROUP 3GM**

**FLANGIA SAE SAEB-SAEBOR\* SAE FLANGE**

**FLANGIA E COPERCHIO IN GHISA - CAST IRON FLANGE AND COVER**

GRUPPO GROUP 3GM	CILINDRATA DISPLACEMENT		PRESSIONE MAX - MAX PRESSURE								VELOCITÀ MAX MAX SPEED	PORTATA MAX MAX FLOW		VELOCITÀ MIN MIN SPEED
			S - D		R		S - D		R					
	cm³/giro	in³/rev	P1 bar	P1 psi	P1 bar	P1 psi	P2 bar	P2 psi	P2 bar	P2 psi	giri/min - rpm	l/min	Gal/min	giri/min - rpm
<b>3GM 190</b>	19.3	1.2	250	3625	215	3117	265	3842	230	3335	3500	67.6	17.84	600
<b>3GM 230</b>	23.0	1.4	250	3625	215	3117	265	3842	230	3335	3500	80.3	21.22	600
<b>3GM 300</b>	30.2	1.8	240	3480	205	2972	255	3621	220	3190	3300	99.7	26.33	600
<b>3GM 340</b>	33.8	2.1	240	3480	205	2972	255	3621	220	3190	3300	111.6	29.49	600
<b>3GM 370</b>	37.5	2.3	230	3335	195	2827	245	3552	210	3045	3300	123.6	32.66	600
<b>3GM 440</b>	44.6	2.7	220	3190	190	2755	235	3407	205	2972	3000	133.8	35.35	600
<b>3GM 530</b>	53.0	3.2	210	3045	180	2610	225	3262	195	2827	3000	159.1	42.04	600
<b>3GM 620</b>	62.7	3.8	190	2755	160	2320	200	2900	170	2465	2500	156.8	41.41	600
<b>3GM 700</b>	70.5	4.3	180	2610	155	2247	190	2755	165	2392	2500	176.3	46.58	600
<b>3GM 770</b>	77.2	4.7	170	2465	145	2102	180	2610	155	2247	2200	169.8	44.84	600

Nota - Per valori di pressione superiori a quelli indicati contattare il Servizio Commerciale.  
Note - for higher pressure values please contact our Sales Dpt.

**DIMENSIONI • DIMENSIONS**

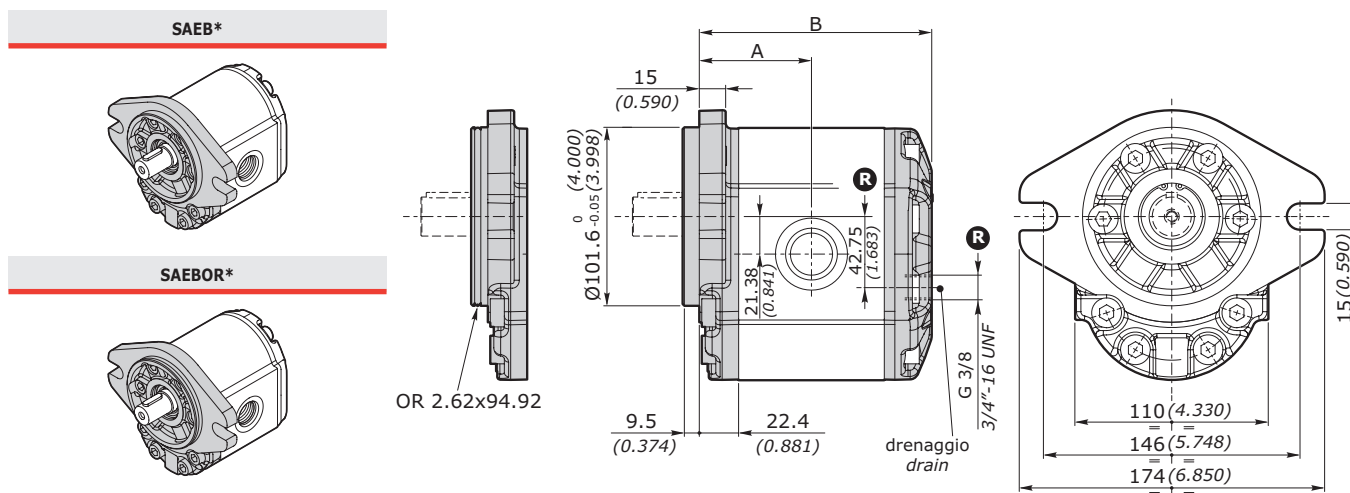

**R** Solo per motori reversibili - Only for reversible motors

\* Contattare il servizio commerciale. / Available soon. Please contact our Sales Dpt.

GRUPPO - GROUP 3	A		B		MASSA - MASS	
	mm	inch	mm	inch	kg	lbs
<b>3GM 190</b>	62.4	2.456	128.3	5.051	7.67	16.91
<b>3GM 230</b>	63.9	2.515	131.3	5.169	7.81	17.21
<b>3GM 300</b>	66.9	2.633	137.3	5.405	8.09	17.82
<b>3GM 340</b>	68.4	2.692	140.3	5.523	8.22	18.12
<b>3GM 370</b>	69.9	2.751	143.3	5.641	8.36	18.43
<b>3GM 440</b>	72.9	2.870	149.3	5.877	8.64	19.04
<b>3GM 530</b>	76.4	3.007	156.3	6.153	8.96	19.75
<b>3GM 620</b>	80.4	3.165	164.3	6.468	9.33	20.56
<b>3GM 700</b>	86.9	3.421	170.8	6.724	9.63	21.22
<b>3GM 770</b>	92.4	3.637	176.3	6.940	9.88	21.77

**MOTORI AD INGRANAGGI GRUPPO 3GM**  
**GEAR MOTORS GROUP 3GM**
**CODICE ORDINAZIONE • ORDER CODE**
**3GM - G - 340 - D - EUR - H - N - 10 - 0 - G**

SIGLA - CODE	TIPO - TYPE	DESCRIZIONE - DESCRIPTION	PAGINA - PAGE
<b>3GM</b>	Tipo motore <i>Motor type</i>	Motore - gruppo 3 <i>Motor - group 3</i>	102
<b>G</b>	Materiale flangia e coperchio <i>Flange and cover material</i>	<b>G</b> = Ghisa / <i>Cast iron</i>	159
<b>340</b>	Cilindrata <i>Displacement</i>	Cilindrata = 33.8 cm <sup>3</sup> /g <i>Displacement = 2.10 in<sup>3</sup>/rev</i>	102
<b>D</b>	Senso di rotazione <i>Rotation wise</i>	<b>D</b> = Rotazione destra / <i>Clockwise rotation</i> <b>S</b> = Rotazione sinistra / <i>Anticlockwise rotation</i> <b>R</b> = Reversibile / <i>Reversible</i> <b>X</b> = Reversibile con drenaggio interno <i>Reversible with internal drain</i>	104
<b>EUR</b>	Tipo Flangia <i>Flange type</i>	Flangia standard europea <i>European standard flange</i>	159
<b>H</b>	Tipo anello di tenuta <i>Seal ring type</i>	Vedi tabella compatibilità <i>See compatibility table</i>	
<b>N</b>	Tipo guarnizione <i>Gasket type</i>	<b>N</b> = NBR <b>V</b> = Viton	160
<b>10</b>	Tipo Albero <i>Shaft type</i>	Vedi tabella compatibilità <i>See compatibility table</i>	160
<b>0</b>	Posizione connessione <i>Connection position</i>	Vedi tabella compatibilità <i>See compatibility table</i>	162
<b>G</b>	Tipo connessione <i>Connection type</i>	Vedi tabella compatibilità <i>See compatibility table</i>	163





**MOTORI AD INGRANAGGI GRUPPO 3GM**  
**GEAR MOTORS GROUP 3GM**

**TIPOLOGIA FLANGIA • FLANGE TYPE**

	EUR	SAEB*	SAEBOR*
<b>3GM</b>			
<b>A</b> alluminio aluminium	non disponibile not available	non disponibile not available	non disponibile not available
<b>G</b> ghisa cast iron	◇	◇	◇

◇ = Combinazione standard - Standard combination

\* Contattare il servizio commerciale. / Available soon. Please contact our Sales Dpt.

**ANELLO DI TENUTA • SEAL RING**

SIGLA - CODE	TIPO - TYPE	DIAGRAMMA - DIAGRAM
--------------	-------------	---------------------

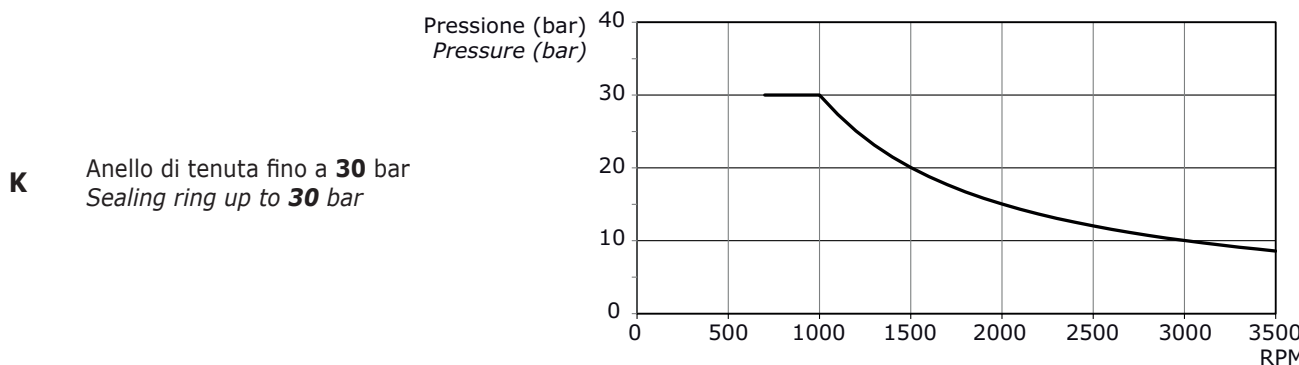
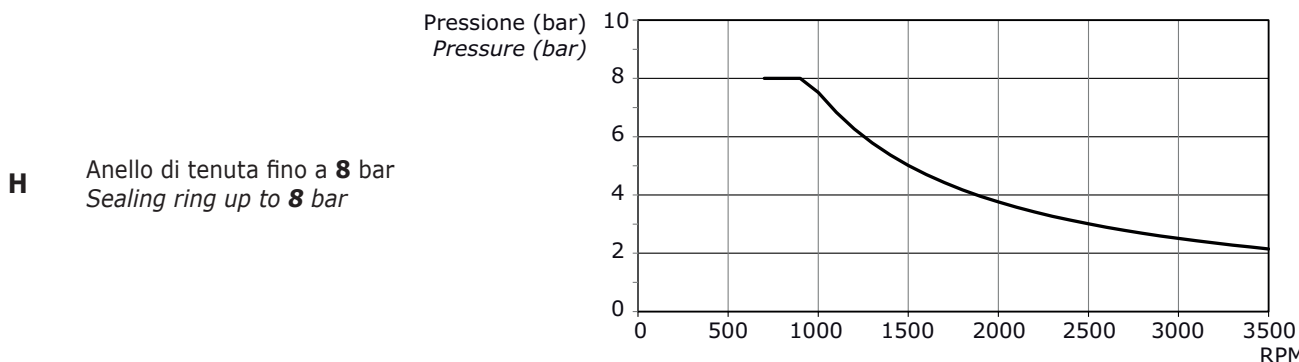

**MOTORI AD INGRANAGGI GRUPPO 3GM**  
**GEAR MOTORS GROUP 3GM**
**COMBINAZIONE FLANGIA - ANELLO DI TENUTA - GUARNIZIONE • FLANGE - SEAL RING - GASKET COMBINATION**

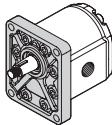
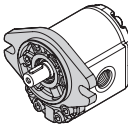
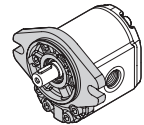
<b>3GM</b>		EUR			SAEB*			SAEBOR*		
										
		Anello - seal ring			Anello - seal ring			Anello - seal ring		
	H	K	W	H	K	W	H	K	W	
NBR	<b>N</b>	◇	◇	◇	◇	◇	◇	◇	◇	◇
Viton	<b>V</b>	●	●	●	●	●	●	●	●	●

 esempio • example: **3GM - G - 340 - D - EUR - H - N - 10 - 0 - G**
**EUR** = flangia europea std / Std European flange

**H** = Anello tenuta fino a 8 bar / Seal ring up to 8 bar

**N** = guarnizione in NBR / NBR o-ring

**COMBINAZIONE ALBERO - FLANGIA • SHAFT - FLANGE COMBINATION**

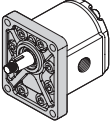
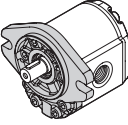
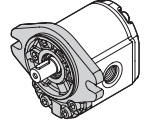
<b>3GM</b>		EUR	SAEB*	SAEBOR*
				
<b>10</b> Conico 1:8 Tapered 1:8	◇	●	●	
<b>13</b> Cilindrico SAEB SAEB Parallel shaft	●	◇	◇	
<b>14</b> Scanalato SAEB 13T (38.2) SAEB 13T splined (38.2)	●	◇	◇	
<b>14R</b> Scanalato SAEB 13T (44.7) SAEB 13T splined (44.7)	●	●	●	

◇ = Combinazione standard - Standard combination

● = Combinazione disponibile - Available combination

\* Contattare il Servizio Commerciale. / Available soon. Please contact our Sales Dpt.

**MOTORI AD INGRANAGGI GRUPPO 3GM**  
**GEAR MOTORS GROUP 3GM**

**3GM**

DIMENSIONI ALBERO - SHAFT DIMENSIONS

<p><b>10</b>                      Conico 1:8                      Tapered 1:8</p> <p>Coppia 240 Nm                      Torque 178 ft-lbs</p>	<p>Disponibile per - available for: <b>EUR - SAEB - SAEBOR</b></p>
<p><b>13</b>                      Cilindrico SAEB                      SAEB Parallel shaft</p> <p>Coppia 200 Nm                      Torque 148 ft-lbs</p>	<p>Disponibile per - available for: <b>EUR - SAEB - SAEBOR</b></p>
<p><b>14</b>                      Scanalato SAEB                      13T (38.2)                      SAEB 13T                      splined (38.2)</p> <p>Coppia 270 Nm                      Torque 200 ft-lbs</p>	<p>Profilo scanalato 7/8"                      SAE 16/32 DP                      n. Denti = 13                      Splined profile 7/8"                      SAE 16/32 DP                      nr. of teeth = 13</p> <p>Disponibile per - available for: <b>EUR - SAEB - SAEBOR</b></p>
<p><b>14R</b>                      Scanalato SAEB                      13T (44.7)                      SAEB 13T                      splined (44.7)</p> <p>Coppia 270 Nm                      Torque 200 ft-lbs</p>	<p>Profilo scanalato 7/8"                      SAE 16/32 DP                      n. Denti = 13                      Splined profile 7/8"                      SAE 16/32 DP                      nr. of teeth = 13</p> <p>Disponibile per - available for: <b>EUR - SAEB - SAEBOR</b></p>

**MOTORI AD INGRANAGGI GRUPPO 3GM**  
**GEAR MOTORS GROUP 3GM**
**POSIZIONE CONNESSIONE PER MOTORI (D-S) • CONNECTION POSITION FOR (D-S) MOTORS**

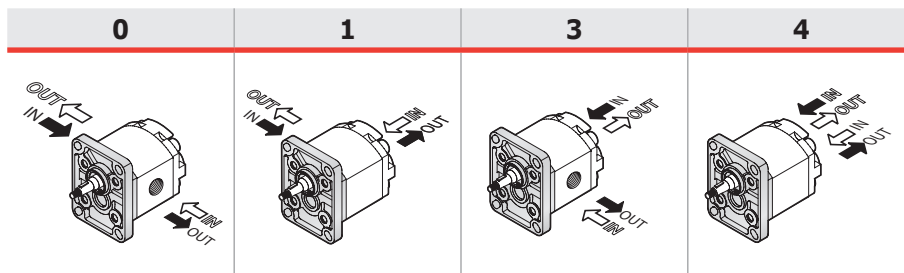
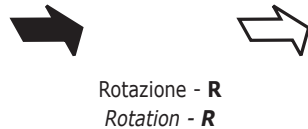
**POSIZIONE CONNESSIONE PER MOTORI (R) • CONNECTION POSITION FOR (R) MOTORS**

**COPERCHIO STANDARD • STANDARD COVER**

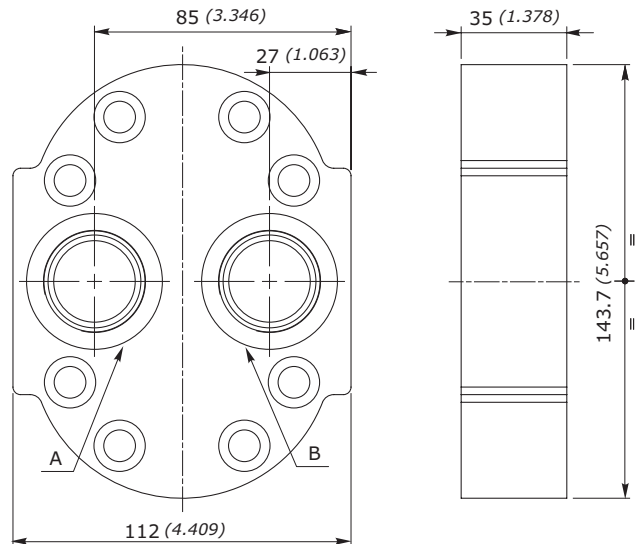
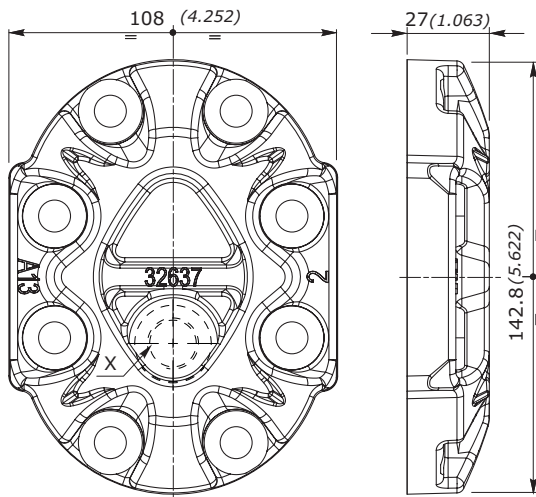
 Per posizione **0**  
 For position **0**

 Per posizioni **1, 3, 4**  
 For position **1, 3, 4**

**CONNESSIONI / CONNECTION**

X	
<b>GAS</b>	G 3/8
<b>SAE</b>	SAE 8

**CONNESSIONI / CONNECTION**

	A	B
<b>GAS</b>	G 1	G 1
<b>SAE</b>	SAE 16	SAE 12

NOTA - (X) Coperchio standard disponibile con drenaggio G 3/8 e SAE 8 contattare il Servizio Commerciale.

Note - (X) Available standard cover with drain G 3/8 and SAE 8. Please contact our Sales Dpt.

**MOTORI AD INGRANAGGI GRUPPO 3GM**  
**GEAR MOTORS GROUP 3GM**

**TIPO CONNESSIONE PER MOTORI D-S • CONNECTION TYPE FOR D-S MOTORS**

Le connessioni rappresentate corrispondono alle versioni standard; per connessioni differenti, contattare il nostro Ufficio Commerciale. *The connection types shown correspond to standard configurations; for different applications contact our Commercial Dept.*

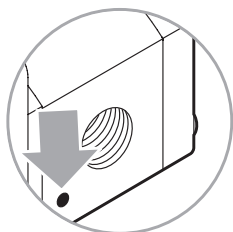

Il segno sul corpo indica il lato scarico per i motori  
 The sign on the body identifies the outlet side for the motors



**IN = INGRESSO - INLET**  
**OUT = SCARICO - OUTLET**

3GM		POSIZIONE CONNESSIONE - CONNECTION POSITION			
		0	1	3	4
GAS	<b>G</b>	◇	◇	◇	◇
UNF	<b>W</b>	◇	◇	◇	◇
FLANGIATE FLANGED	<b>T</b>	◇			
	<b>N</b>	◇			
	<b>F</b>	◇			

GAS	UNI ISO 228/1	SIGLA CODE	CIL. DISPL.	SCARICO - OUTLET OUT			INGRESSO - INLET IN		
				A	B	↻	A	B	↻
	G	G	190	G 1"	20 [mm] 0.788 [inch]	70 [Nm] 620 [in.lbs]	G 3/4"	17 [mm] 0.670 [in.lbs]	60 [mm] 531 [in.lbs]
			230						
			300						
			340						
			370						
			440						
			530						
			620						
			700						
770									

UNF	ANSI/ASME B1.1	SIGLA CODE	CIL. DISPL.	SCARICO - OUTLET OUT			INGRESSO - INLET IN		
				A	B	↻	A	B	↻
	W	W	190	SAE 16 1"5/16-12 UN	20 [mm] 0.788 [inch]	70 [Nm] 620 [in.lbs]	SAE 12 1"1/16-12 UN	20 [mm] 0.788 [inch]	60 [Nm] 531 [in.lbs]
			230						
			300						
			340						
			370						
			440						
			530						
			620						
			700						
770									

**MOTORI AD INGRANAGGI GRUPPO 3GM**  
**GEAR MOTORS GROUP 3GM**

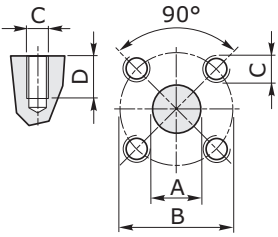
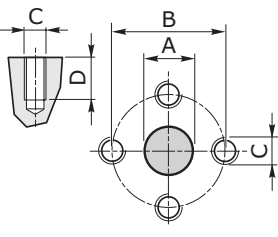
FLANGIATE FLANGED	ISO/R 262	SIGLA CODE	CIL. DISPL.	SCARICO - OUTLET OUT					INGRESSO - INLET IN				
				A	B	C	D		A	B	C	D	
	T	190											
		230											
		300											
		340											
		370	26	55	M8	16	15	18	55	M8	16	15	
		440	[mm] 1.024	[mm] 2.167		[mm] 0.630	[Nm] 133	[mm] 0.709	[mm] 2.167		[mm] 0.630	[Nm] 133	
		530	[inch]	[inch]		[inch]	[in.lbs]	[inch]	[inch]		[inch]	[in.lbs]	
		620											
		700											
		770											
	N	190											
		230											
		300											
		340											
		370	27	51	M10	15	20	19	40	M8	15	15	
		440	[mm] 1.064	[mm] 2.009		[mm] 0.591	[Nm] 177	[mm] 0.748	[mm] 1.575		[mm] 0.591	[Nm] 133	
		530	[inch]	[inch]		[inch]	[in.lbs]	[inch]	[inch]		[inch]	[in.lbs]	
		620											
		700											
		770											

Standard Galtech

Galtech standard

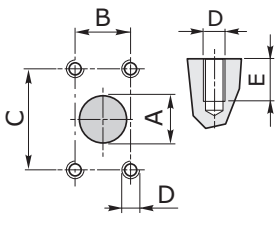
FLANGIATE FLANGED	ISO/R 262	SIGLA CODE	CIL. DISPL.	SCARICO - OUTLET OUT					INGRESSO - INLET IN				
				A	B	C	D	E		A	B	C	D
	F	190											
		230											
		300											
		340											
		370											
		440	27	26.2	52.4	M8	15	15					
		530	[mm] 1.063	[mm] 1.031	[mm] 2.063		[mm] 0.591	[Nm] 133					
		620	[inch]	[inch]	[inch]		[inch]	[in.lbs]					
		700											
		770											

**MOTORI AD INGRANAGGI GRUPPO 3GM**  
**GEAR MOTORS GROUP 3GM**

**TIPO CONNESSIONE PER MOTORI (R) • CONNECTION TYPE FOR (R) MOTORS**

Le connessioni rappresentate corrispondono alle versioni standard; per connessioni differenti, contattare il nostro Ufficio Commerciale. *The connection types shown correspond to standard configurations; for different applications contact our Commercial Dept.*

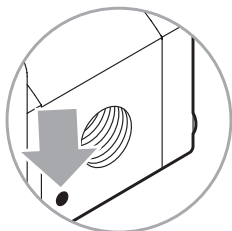

L'eventuale segno sul corpo dei Motori REVERSIBILI non è da considerare.  
 Any sign on the body of REVERSIBLE Motors has not to be considered.



**IN = MANDATA - DELIVERY**  
**OUT = SCARICO - OUTLET**

GAS	<b>G</b>	◇	◇	◇	◇
UNF	<b>W</b>	◇	◇	◇	◇
FLANGIATE FLANGED	<b>T</b>	◇			
	<b>N</b>	◇			
	<b>F</b>	◇			

GAS	UNI ISO 228/1	SIGLA CODE	CIL. DISPL.	SCARICO - OUTLET OUT			INGRESSO - INLET IN		
				A	B	↻	A	B	↻
	G	G	190	G 1"	20 [mm] 0.788 [inch]	70 [Nm] 620 [in.lbs]	G 1"	20 [mm] 0.788 [inch]	70 [Nm] 620 [in.lbs]
			230						
			300						
			340						
			370						
			440						
			530						
			620						
			700						
			770						

UNF	ANSI/ASME B1.1	SIGLA CODE	CIL. DISPL.	SCARICO - OUTLET OUT			INGRESSO - INLET IN		
				A	B	↻	A	B	↻
	W	W	190	SAE 16 1"5/16-12 UN	20 [mm] 0.788 [inch]	70 [Nm] 620 [in.lbs]			
			230						
			300						
			340						
			370						
			440						
			530						
			620						
			700						
			770						

**MOTORI AD INGRANAGGI GRUPPO 3GM**  
**GEAR MOTORS GROUP 3GM**

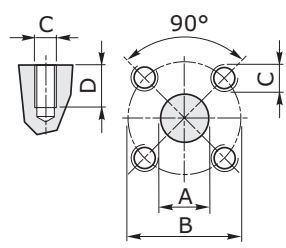
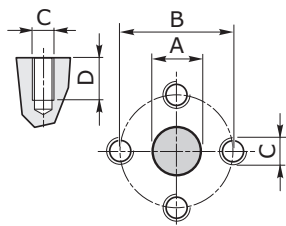
FLANGIATE FLANGED	ISO/R 262	SIGLA CODE	CIL. DISPL.	SCARICO OUTLET OUT					INGRESSO - INLET IN						
				A	B	C	D		A	B	C	D			
		T	190												
			230												
			300												
			340												
			370	26	55		16	15							
			440	1.024	2.167	M8	0.630	133							
			530	[inch]	[inch]		[inch]	[in.lbs]							
			620												
			700												
			770												
		N	190												
			230												
			300												
			340												
			370	27	51		15	20							
			440	1.064	2.009	M10	0.591	177							
			530	[inch]	[inch]		[inch]	[in.lbs]							
			620												
			700												
			770												

Standard Galtech

Galtech standard

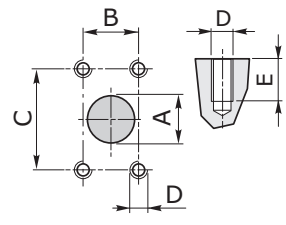
FLANGIATE FLANGED	ISO/R 262	SIGLA CODE	CIL. DISPL.	SCARICO OUTLET OUT					INGRESSO - INLET IN					
				A	B	C	D	E		A	B	C	D	E
		F	190											
			230	27	26.2	52.4		15	15					
			300	1.064	1.031	2.063	M8	0.591	133					
			340	[inch]	[inch]	[inch]		[inch]	[in.lbs]					
			370											
			440											
			530	42	35.6	69.8		15	15					
			620	1.654	1.402	2.748	M8	0.591	133					
			700	[inch]	[inch]	[inch]		[inch]	[in.lbs]					
			770											

\*: Le flange non corrispondono a norma SAEJ518. Flange a norma disponibili a richiesta, contattare il Servizio Commerciale.

\*: Flanges F do not correspond to SAEJ518. Flanges SAEJ518 available on request, please contact our Sales Dpt.



**MOTORI AD INGRANAGGI GRUPPO 3GM**  
**GEAR MOTORS GROUP 3GM**

**OPZIONI • OPTIONS**

**VLPI**

VALVOLA LIMITATRICE DI PRESSIONE A SCARICO INTERNO  
 PRESSURE RELIEF VALVE WITH INTERNAL EXHAUST

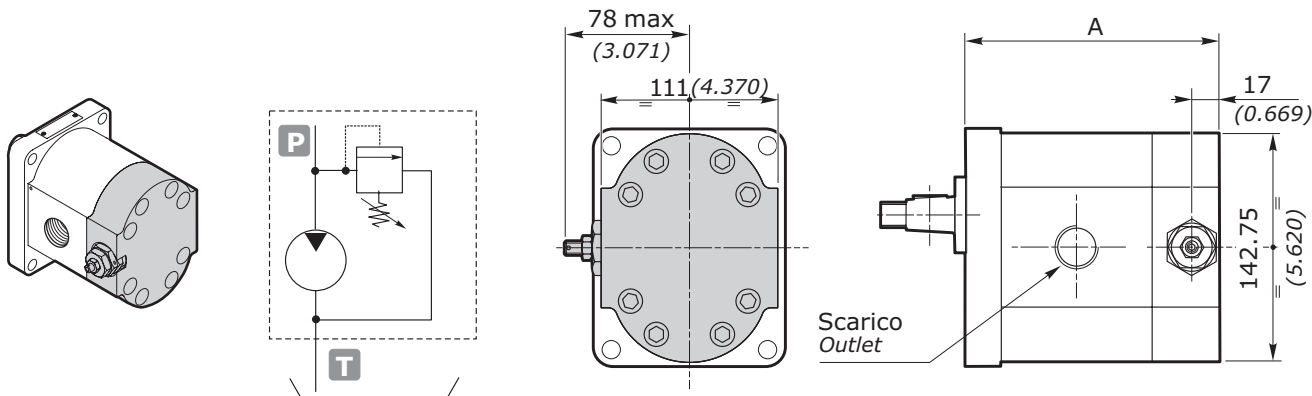

GRUPPO GROUP 3	A	
	EUR - SAEB - SAEBOR mm	inch
<b>3GM 190</b>	146.30	5.759
<b>3GM 230</b>	149.30	5.877
<b>3GM 300</b>	155.30	6.114
<b>3GM 340</b>	158.30	6.232
<b>3GM 370</b>	161.30	6.350
<b>3GM 440</b>	167.30	6.586
<b>3GM 530</b>	174.30	6.862
<b>3GM 620</b>	182.30	7.177
<b>3GM 700</b>	188.30	7.413
<b>3GM 770</b>	194.30	7.649

La valvola limitatrice di pressione si applica sostituendo il coperchio posteriore (previsto solo scarico interno). Il corpo VLP è disponibile in alluminio. È rappresentato un motore con rotazione destra.

*The pressure relief valve can be applied by replacing the rear cover (only internal relief is set). VLP cover is available in aluminum. The shown motor is with clockwise rotation.*

esempio • example: **3GM - A - 340 - D - EUR - H - N - 10 - 0 - G - VLPI (N 120)**

**VLPI** = Coperchio con VPL a scarico interno / Cover with VPL with internal exhaust

**N** = Tipo molla - vedi tabella / Spring type - see table

**120** = Taratura - vedi tabella / Setting - see table

bar	30 ÷ 80	81 ÷ 200	201 ÷ 350
psi	435 ÷ 1160	1175 ÷ 2900	2915 ÷ 5075
STANDARD	70 bar (1015 psi)	150 bar (2175 psi)	250 bar (3625 psi)

NOTA: In caso di omissione del valore di taratura, esso sarà inteso standard (vedi tabella).

NOTE: Without setting request, it will be considered standard (see table).

**MOTORI AD INGRANAGGI GRUPPO 3GM**  
**GEAR MOTORS GROUP 3GM**
**VLPE**

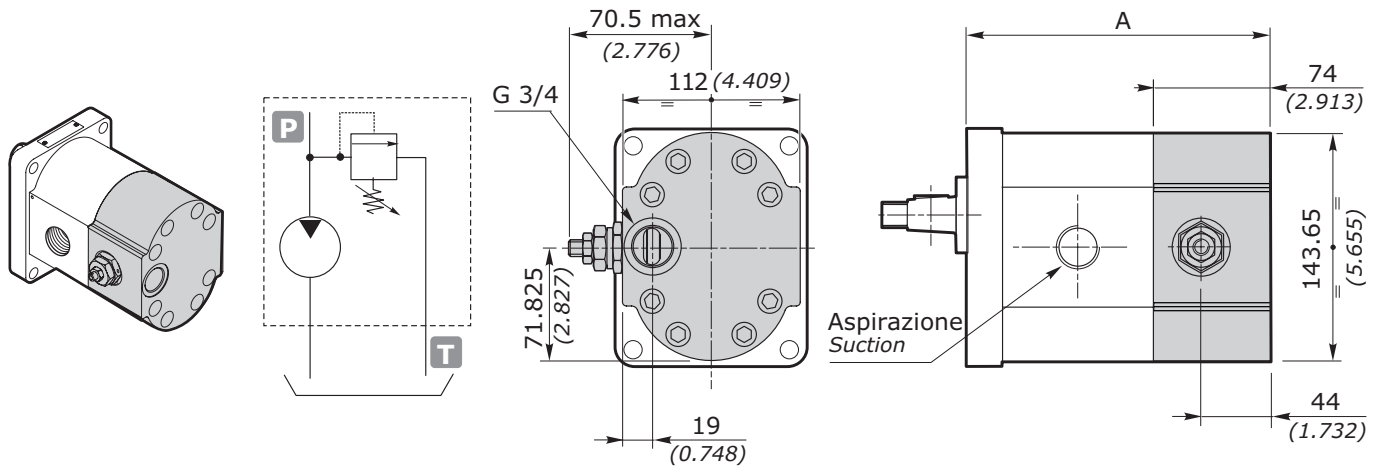
 VALVOLA LIMITATRICE DI PRESSIONE A SCARICO ESTERNO  
 PRESSURE RELIEF VALVE WITH EXTERNAL EXHAUST

GRUPPO GROUP 3	A	
	EUR - SAEB - SAEBOR mm	inch
<b>3GP 190</b>	176.30	6.941
<b>3GP 230</b>	179.30	7.059
<b>3GP 300</b>	185.30	7.295
<b>3GP 340</b>	188.30	7.413
<b>3GP 370</b>	191.30	7.531
<b>3GP 440</b>	197.30	7.767
<b>3GP 530</b>	204.30	8.043
<b>3GP 620</b>	212.30	8.358
<b>3GP 700</b>	218.30	8.594
<b>3GP 770</b>	224.30	8.830

La valvola limitatrice di pressione si applica sostituendo il coperchio posteriore. Il coperchio VLP è disponibile in alluminio. E' rappresentato un motore con rotazione sinistra. Nei motori con rotazione destra, la valvola è dal lato opposto

*The pressure relief valve can be applied by substituting the rear cover. VLP cover is available in aluminum. The showed motor is with anticlockwise rotation. In the case of motors with clockwise rotation, the valve is on the opposite side.*

 esempio • example: **3GM - A - 230 - D - EUR - B - N - 10 - 0 - G - VLPE (N 120)**
**VLPE** = Coperchio con VPL a scarico esterno / Cover with VPL with external exhaust

**N** = Tipo molla - vedi tabella / Spring type - see table

**120** = Taratura - vedi tabella / Setting - see table

TIPO - TYPE	CAMPI DI TARATURE - CALIBRATION FIELDS					
	molla bianca - white spring	B	molla nera - black spring	N	molla rossa - red spring	R
bar	30 ÷ 80		81 ÷ 200		201 ÷ 350	
psi	435 ÷ 1160		1175 ÷ 2900		2915 ÷ 5075	
STANDARD	70 bar (1015 psi)		150 bar (2175 psi)		250 bar (3625 psi)	

NOTA: In caso di omissione del valore di taratura, esso sarà inteso standard (vedi tabella).

NOTE: Without setting request, it will be considered standard (see table).

**ACCESSORI  
ACCESSORIES**

**SUPPORTI • SUPPORTS**

**GRUPPO - GROUP**

SUPPORTO CON ALBERO TIPO 12 • SUPPORT WITH SHAFT TYPE 12

**1**

Codice ordinazione - Order code: **01510400000000**

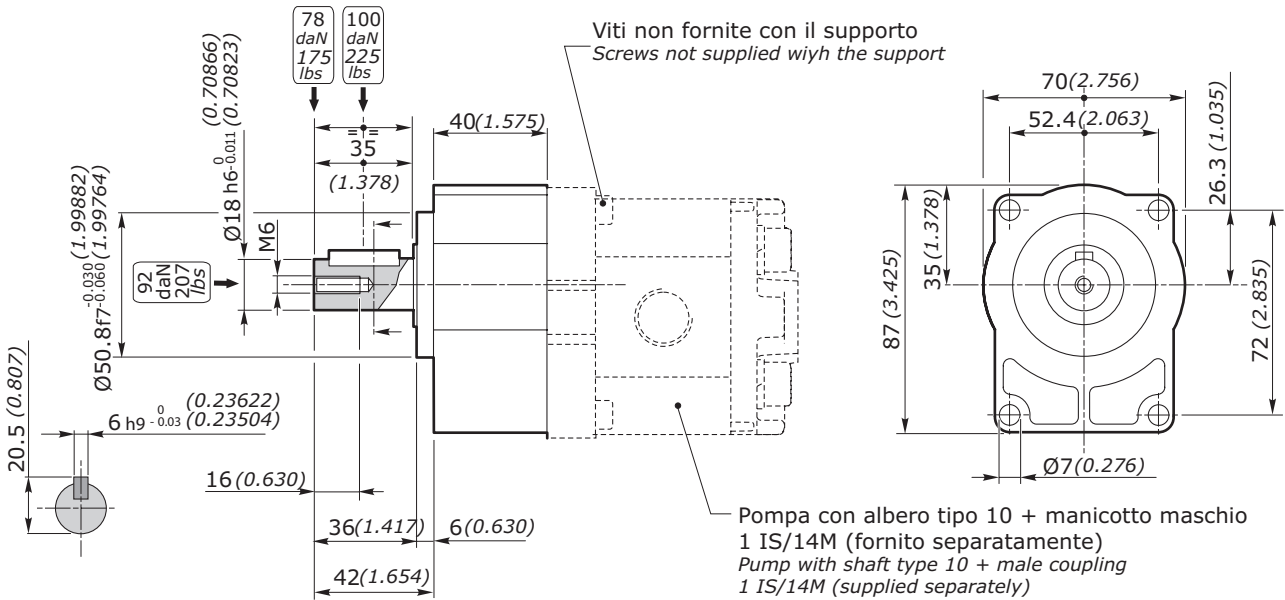

**GRUPPO - GROUP**

SUPPORTO CON ALBERO TIPO 10 • SUPPORT WITH SHAFT TYPE 10

**1**

Codice ordinazione - Order code: **01510500000000**

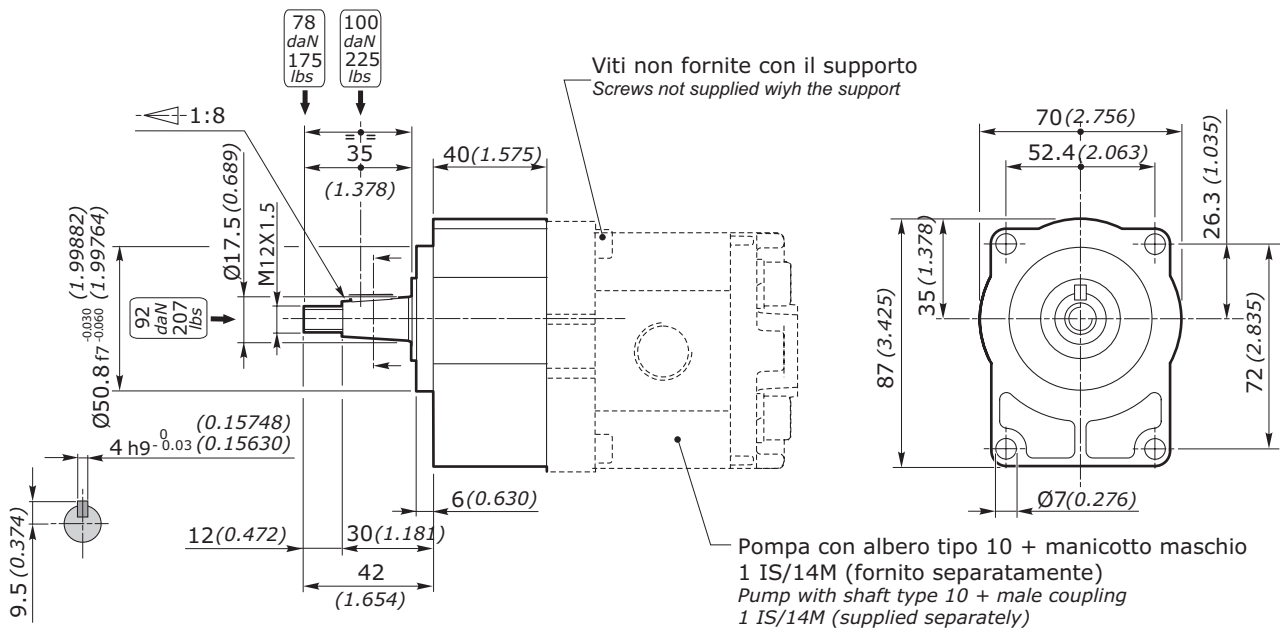

**SUPPORTI • SUPPORTS**
**GRUPPO - GROUP**
**2**

SUPPORTO CON ALBERO TIPO 12 • SUPPORT WITH SHAFT TYPE 12

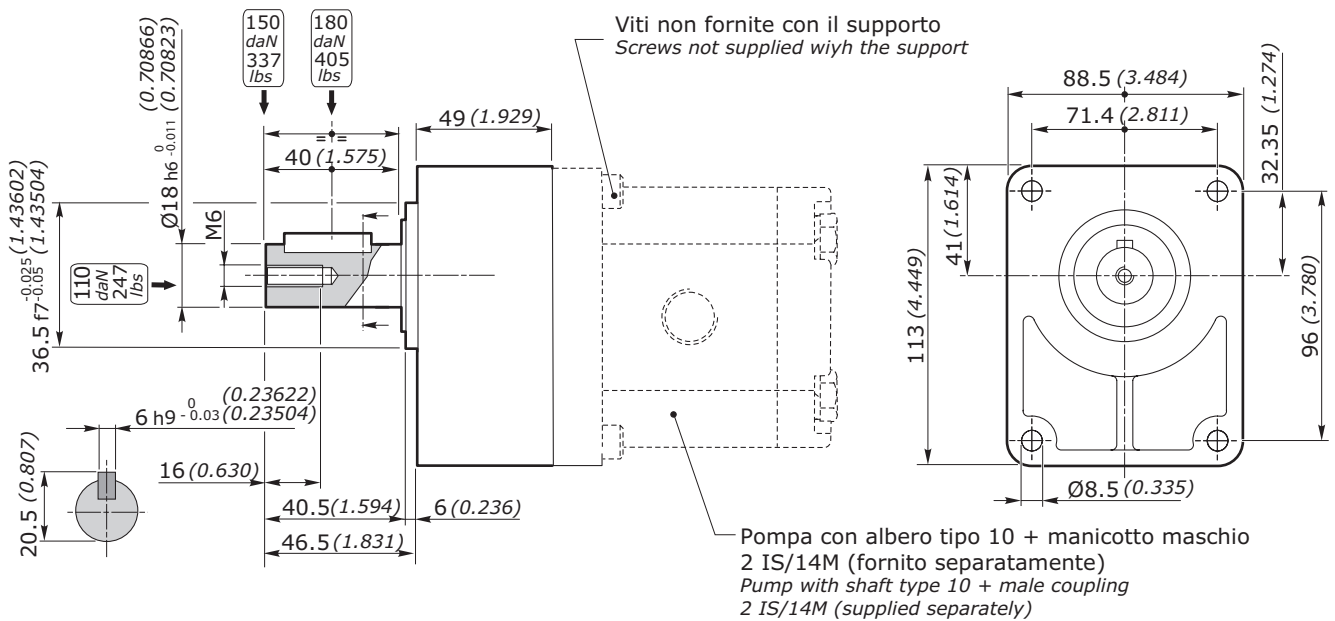
 Codice ordinazione - Order code: **01521200000000**

**GRUPPO - GROUP**
**2**

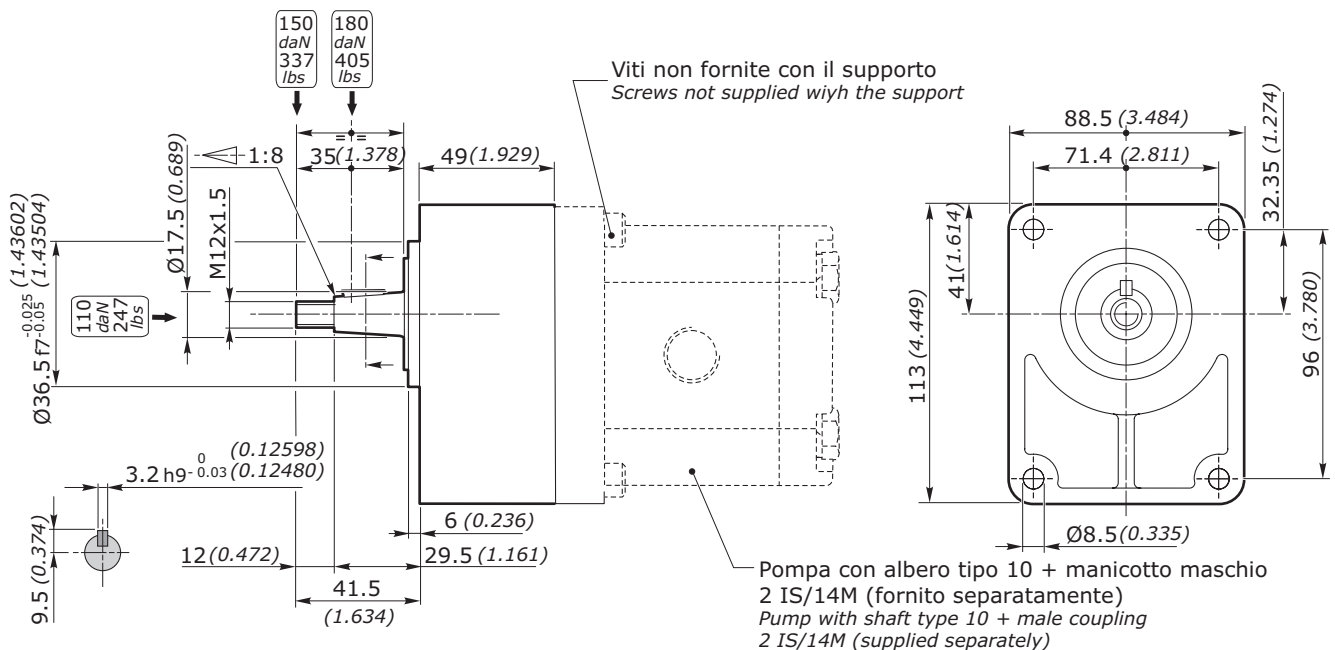
SUPPORTO CON ALBERO TIPO 10 • SUPPORT WITH SHAFT TYPE 10

 Codice ordinazione - Order code: **01521201000000**

**ACCESSORI**  
**ACCESSORIES**

**SUPPORTI • SUPPORTS**

**GRUPPO - GROUP**

**SUPPORTO RINFORZATO CON ALBERO TIPO 12 • REINFORCED SUPPORT WITH SHAFT TYPE 12**

**2**

Codice ordinazione - Order code: **01521300000000**

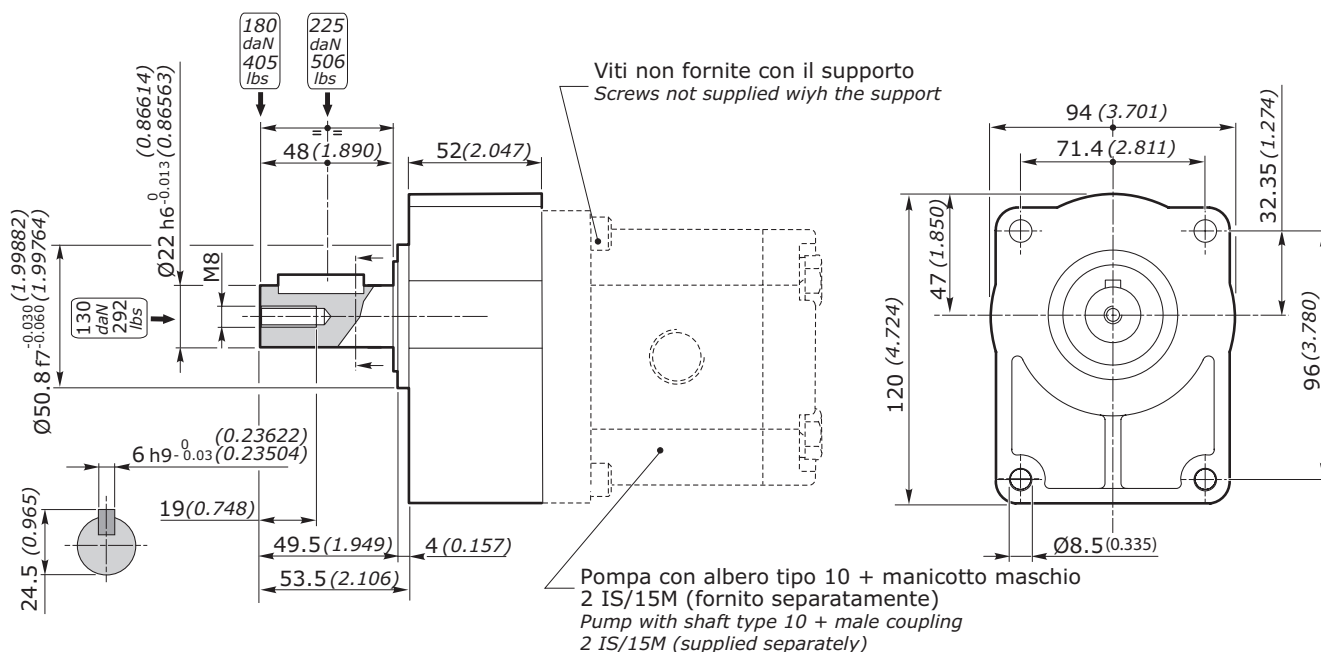

**GRUPPO - GROUP**

**SUPPORTO RINFORZATO CON ALBERO TIPO 10 • REINFORCED SUPPORT WITH SHAFT TYPE 10**

**2**

Codice ordinazione - Order code: **01521301000000**

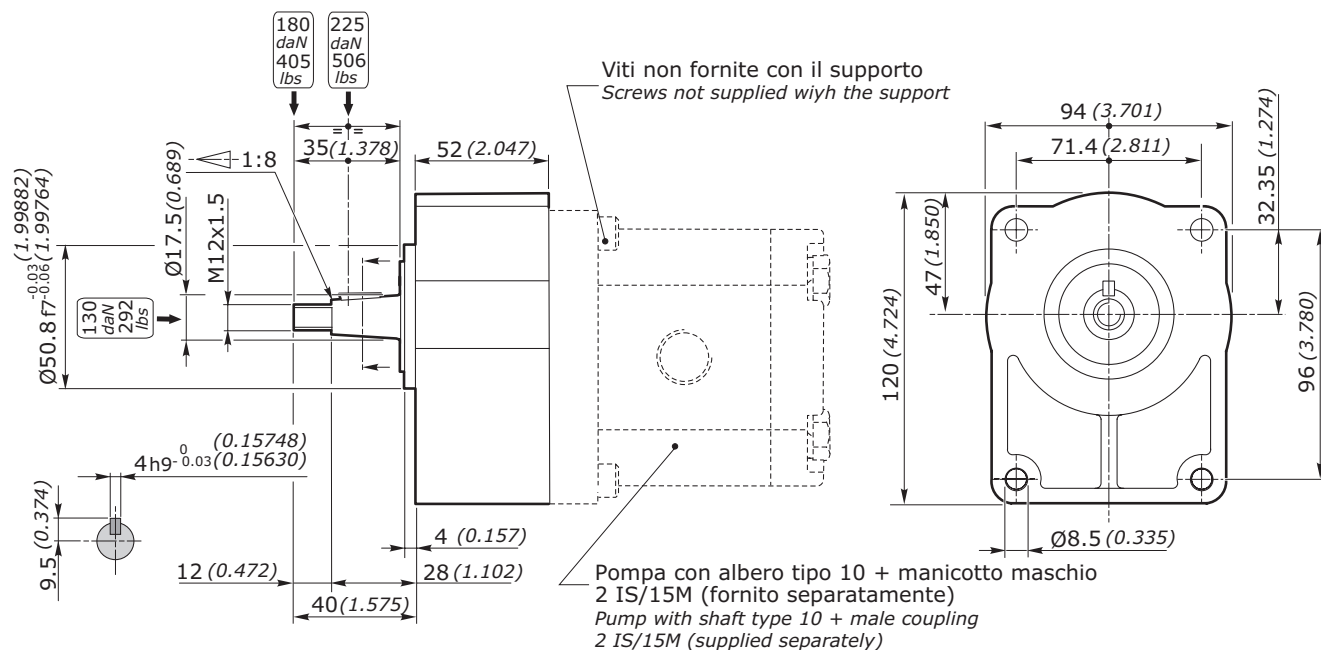

**SUPPORTI • SUPPORTS**
**GRUPPO - GROUP**
**3**

SUPPORTO CON ALBERO TIPO 12 • SUPPORT WITH SHAFT TYPE 12

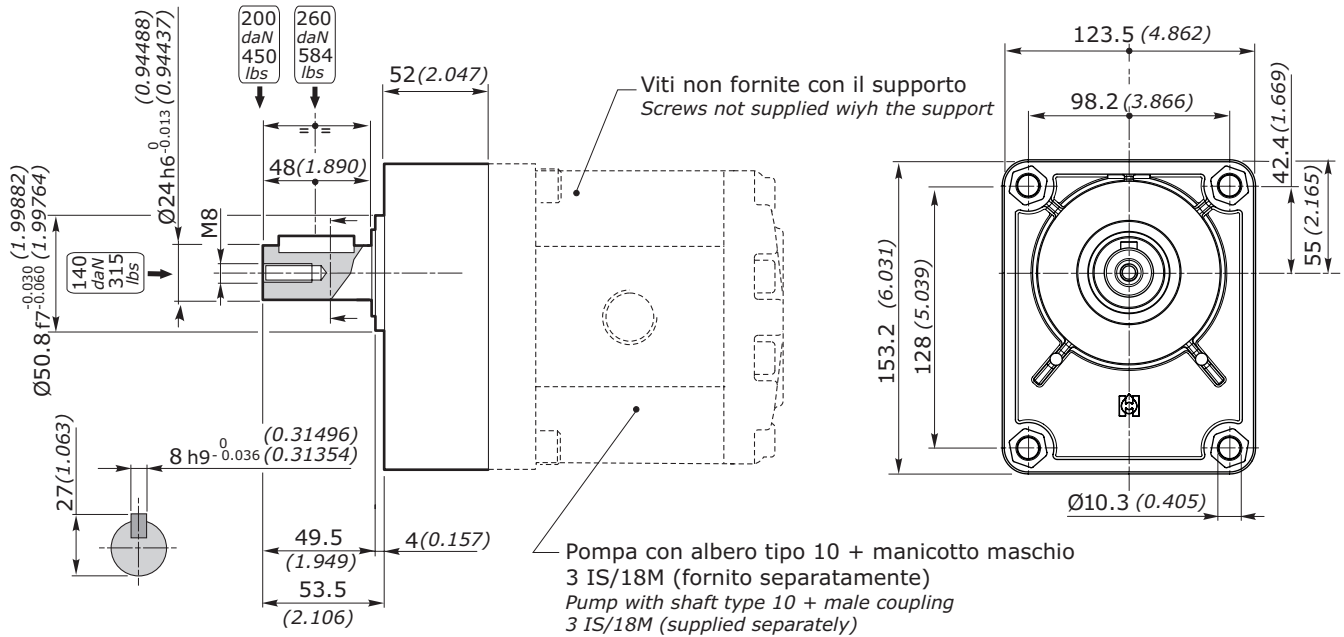
 Codice ordinazione - Order code: **01530210000000**

**GRUPPO - GROUP**
**3**

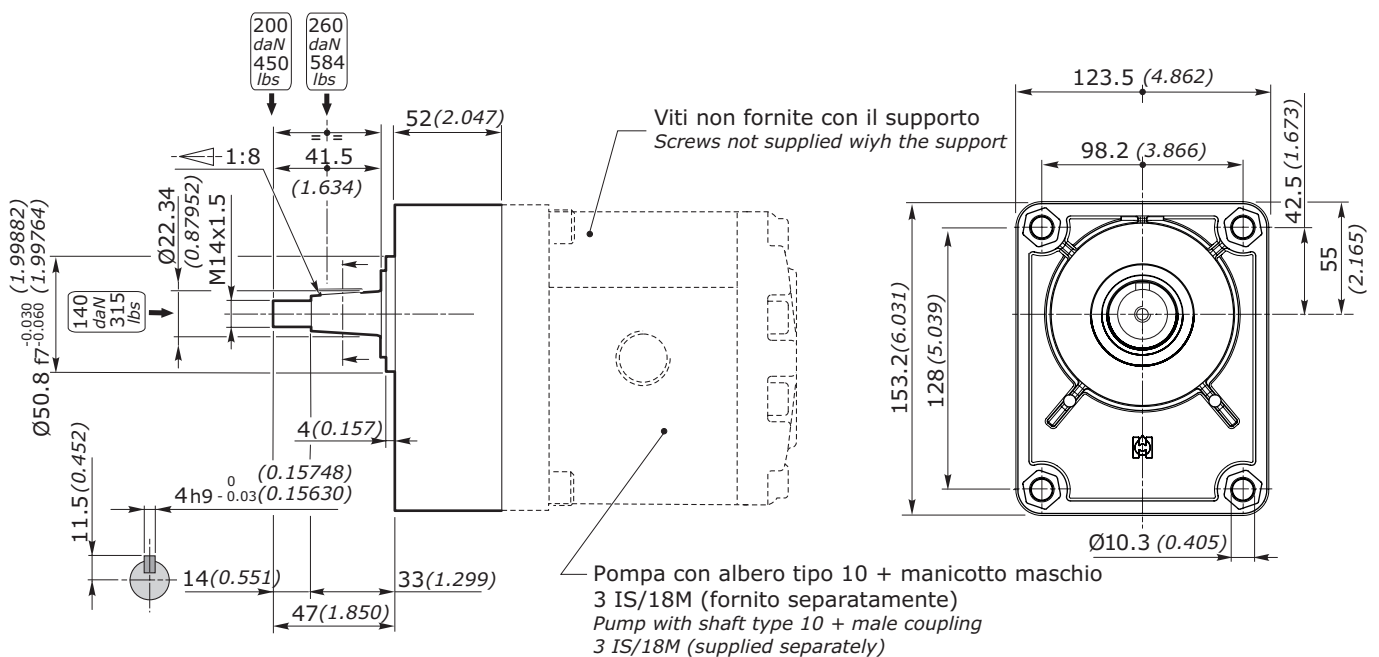
SUPPORTO CON ALBERO TIPO 12 • SUPPORT WITH SHAFT TYPE 12

 Codice ordinazione - Order code: **01530220000000**

**ACCESSORI  
ACCESSORIES**

**RACCORDI • CONNECTORS**

**RACCORDO A GOMITO • ELBOW CONNECTOR**

per connessioni tipo "N" - for connections type "N"

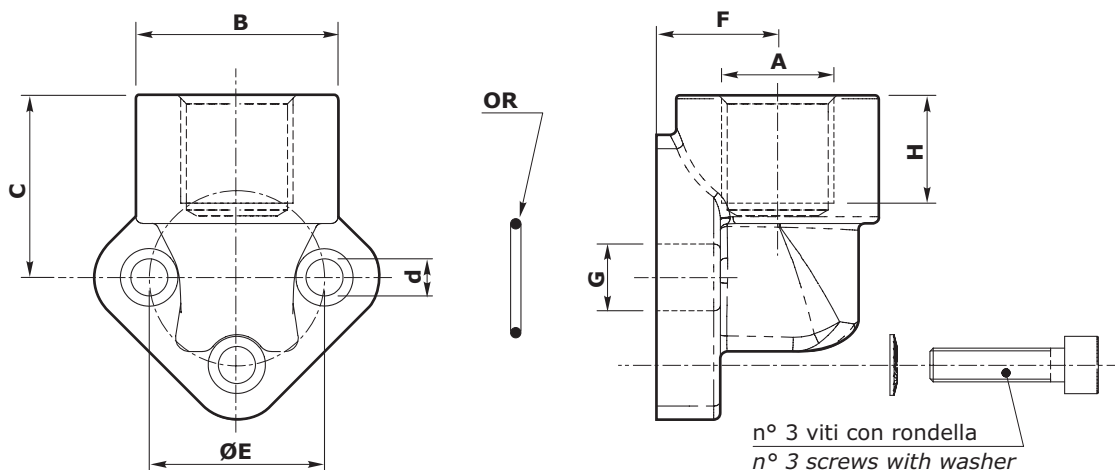

**ACCIAIO • STEEL**

TIPO - TYPE	A	B		C		d		E		F		G		H		OR
		mm	inch	mm	inch	mm	inch	mm	inch	mm	inch	mm	inch			
<b>FG 3/8" - 26</b>	G 3/8	30	1.181	27.5	1.083	5.5	0.217	26	1.024	17	0.669	11	0.433	12	0.472	14.00 X 1.78
<b>FG 3/8" - 30</b>	G 3/8	30	1.181	27.5	1.083	6.5	0.256	30	1.181	17	0.669	12	0.472	12	0.472	15.88 X 2.62
<b>FG 1/2" - 30</b>	G 1/2	30	1.181	27.5	1.083	6.5	0.256	30	1.181	17	0.669	12	0.472	12	0.472	15.88 X 2.62
<b>FG 3/4" - 40</b>	G 3/4	38	1.496	36	1.417	8.5	0.335	40	1.575	21	0.817	19	0.748	16	0.630	23.81 X 2.62
<b>FG 1" - 51</b>	G 1	45	1.772	47	1.850	10.5	0.413	51	2.008	26	1.024	25	0.984	18	0.709	31.42 X 2.62
<b>FG 1 1/2" - 72.5</b>	G 1 1/2	63	2.480	56	2.205	13	0.512	72,5	2.854	34.5	1.358	40	1.575	24	0.945	47.22 X 3.53

ACCIAIO - STEEL	
TIPO - TYPE	CODICE ORDINAZIONE - ORDER CODE
<b>FG 3/8" - 26</b>	0160000000000000
<b>FG 3/8" - 30</b>	0161000000000000
<b>FG 1/2" - 30</b>	0162000000000000
<b>FG 3/4" - 40</b>	0163000000000000
<b>FG 1" - 51</b>	0164000000000000
<b>FG 1 1/2" - 72.5</b>	0165000000000000

**RACCORDI • CONNECTORS**
**RACCORDO A GOMITO • ELBOW CONNECTOR**

per connessioni tipo "T" - for connections type "T"

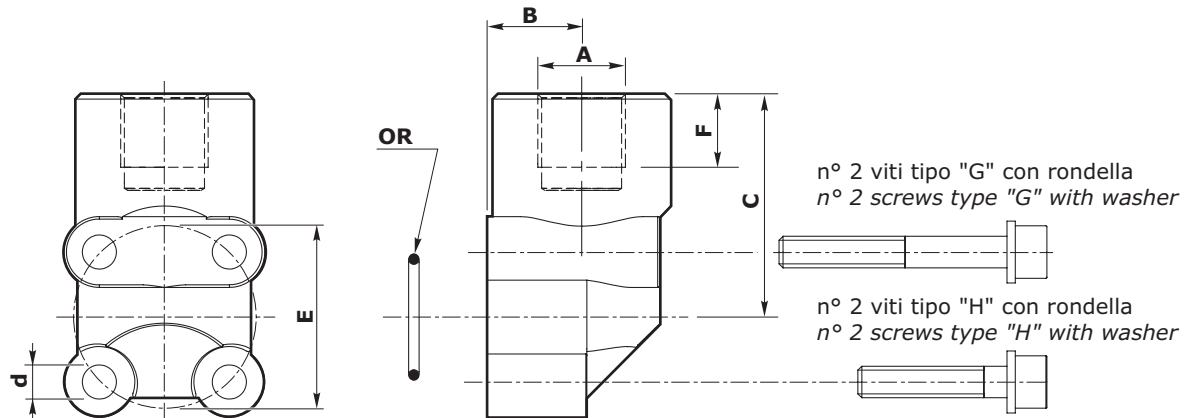
**ACCIAIO • STEEL**

TIPO - TYPE	A	B		C		d		E		F		OR	VITI TIPO H SCREW TYPE H	VITI TIPO G SCREW TYPE G
		mm	inch	mm	inch	mm	inch	mm	inch	mm	inch			
<b>FG 3/8" 0.5 BKA</b>	G 3/8	18	0.709	40	1.575	6.5	0.256	30	1.181	16	0.630	15.88 X 2.62	M6 X 35 UNI 5931	M6 X 45 UNI 5931
<b>FG 1/2" 0.5 BKA</b>	G 1/2	18	0.709	40	1.575	6.5	0.256	30	1.181	16	0.630	15.88 X 2.62		
<b>FG 3/8" 1 BKA</b>	G 3/8	18	0.709	40	1.575	6.5	0.256	35	1.378	16	0.630	18.72 X 2.62	M6 X 20 UNI 5931	M6 X 35 UNI 5931
<b>FG 1/2" 1 BKA</b>	G 1/2	18	0.709	40	1.575	6.5	0.256	35	1.378	16	0.630	18.72 X 2.62		
<b>FG 1/2" 2 BKA</b>	G 1/2	24	0.945	41.5	1.634	6.5	0.256	40	1.575	16	0.630	23.81 X 2.62		M6 X 45 UNI 5931
<b>FG 3/4" 2 BKA</b>	G 3/4	24	0.945	41.5	1.634	6.5	0.256	40	1.575	16	0.630	23.81 X 2.62		

**ALLUMINIO • ALUMINIUM**

TIPO - TYPE	A	B		C		d		E		F		OR	VITI TIPO H SCREW TYPE H	VITI TIPO G SCREW TYPE G
		mm	inch	mm	inch	mm	inch	mm	inch	mm	inch			
<b>FG 3/8" 0.5 BKAL</b>	G 3/8	18	0.709	40	1.575	6.5	0.256	30	1.181	14	0.551	15.88 X 2.62	M6 X 30 UNI 5931	M6 X 45 UNI 5931
<b>FG 1/2" 0.5 BKAL</b>	G 1/2	18	0.709	40	1.575	6.5	0.256	30	1.181	14	0.551	15.88 X 2.62		
<b>FG 3/8" 1 BKAL</b>	G 3/8	18	0.709	40	1.575	6.5	0.256	35	1.378	16	0.630	18.72 X 2.62		
<b>FG 1/2" 1 BKAL</b>	G 1/2	18	0.709	40	1.575	6.5	0.256	35	1.378	16	0.630	18.72 X 2.62	M6 X 35 UNI 5931	M6 X 55 UNI 5931
<b>FG 1/2" 2 BKAL</b>	G 1/2	24	0.945	41.5	1.634	6.5	0.256	40	1.575	16	0.630	23.81 X 2.62		
<b>FG 3/4" 2 BKAL</b>	G 3/4	24	0.945	41.5	1.634	6.5	0.256	40	1.575	16	0.630	23.81 X 2.62		

**ACCIAIO - STEEL**

TIPO - TYPE	CODICE ORDINAZIONE - ORDER CODE
<b>FG 3/8" 0.5 BKA</b>	-
<b>FG 1/2" 0.5 BKA</b>	-
<b>FG 3/8" 1 BKA</b>	016999110000000
<b>FG 1/2" 1 BKA</b>	016999120000000
<b>FG 1/2" 2 BKA</b>	016999220000000
<b>FG 3/4" 2 BKA</b>	016999230000000

**ALLUMINIO - ALUMINIUM**

TIPO - TYPE	CODICE ORDINAZIONE - ORDER CODE
<b>FG 3/8" 0.5 BKAL</b>	016998010000000
<b>FG 1/2" 0.5 BKAL</b>	016998020000000
<b>FG 3/8" 1 BKAL</b>	016998110000000
<b>FG 1/2" 1 BKAL</b>	016998120000000
<b>FG 1/2" 2 BKAL</b>	016998220000000
<b>FG 3/4" 2 BKAL</b>	016998230000000



**ACCESSORI  
ACCESSORIES**

**MANICOTTI DI TRASCINAMENTO • MALE COUPLING**

MANICOTTO DI TRASCINAMENTO POMPE • COUPLING FOR GEAR PUMPS

maschio - male

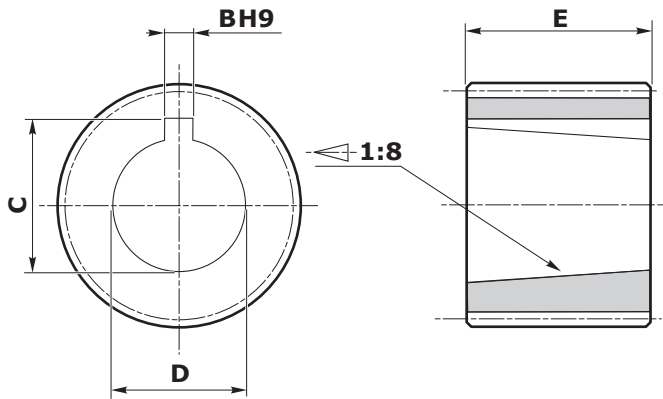

TIPO - TYPE	CODICE ORDINAZIONE - ORDER CODE
<b>1 IS / 12M</b>	018001000000000
<b>1 IS / 14M</b>	018002000000000
<b>2 IS / 14M</b>	018003000000000
<b>2 IS / 15M</b>	018004000000000
<b>3 IS / 18M</b>	018005000000000
<b>4 IS / 23M</b>	018006000000000

TIPO - TYPE	PROFILO PROFILE DIN 5482	N. DENTI N. TEETH	B		C		D		E		COPPIA SERRAGGIO DADO-GIUNTO NUT-JOINT SCREW TIGHTENING TORQUE	
			mm	inch	mm	inch	mm	inch	mm	inch	Nm	in-lbs
<b>1 IS / 12M</b>	B20 X 17	12	2.4	0.094	9.6	0.378	7.82	0.308	14.5	0.571	9 ÷ 10	80 ÷ 89
<b>1 IS / 14M</b>	B25 X 22	14	2.4	0.094	9.6	0.378	7.82	0.308	14.5	0.571	9 ÷ 10	80 ÷ 89
<b>2 IS / 14M</b>	B25 X 22	14	3.17	0.125	16.5	0.650	14.31	0.563	22	0.866	22 ÷ 25	195 ÷ 221
<b>2 IS / 15M</b>	B28 X 25	15	3.17	0.125	15.8	0.622	14.31	0.563	22	0.866	32 ÷ 35	283 ÷ 310
<b>3 IS / 18M</b>	B35 X 31	18	4	0.157	21	0.827	18.39	0.724	26	1.024	50 ÷ 55	443 ÷ 487
<b>4 IS / 23M</b>	B48 X 44	23	6.35	0.250	30.2	1.189	27.50	1.083	42	1.654	100 ÷ 120	885 ÷ 1062

MANICOTTO DI TRASCINAMENTO POMPE • COUPLING FOR GEAR PUMPS

femmina - female

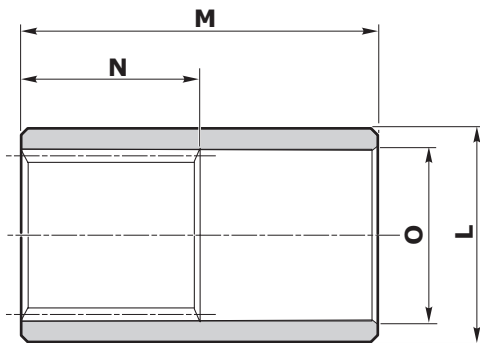

TIPO - TYPE	CODICE ORDINAZIONE - ORDER CODE
<b>1 IS / 12F</b>	018021000000000
<b>1 IS / 14F</b>	018022000000000
<b>2 IS / 15F</b>	018023000000000
<b>3 IS / 18F</b>	018024000000000
<b>4 IS / 23F</b>	018025000000000

TIPO - TYPE	PROFILO PROFILE DIN 5482	N. DENTI N. TEETH	L		M		N		O	
			mm	inch	mm	inch	mm	inch	mm	inch
<b>1 IS / 12F</b>	A20 X 17	12	2.4	0.094	9.6	0.378	7.82	0.308	14.5	0.571
<b>1 IS / 14F</b>	A25 X 22	14	2.4	0.094	9.6	0.378	7.82	0.308	14.5	0.571
<b>2 IS / 15F</b>	A28 X 25	15	3.17	0.125	15.8	0.622	14.31	0.563	22	0.866
<b>3 IS / 18F</b>	A35 X 31	18	4	0.157	21	0.827	18.39	0.724	26	1.024
<b>4 IS / 23F</b>	A48 X 44	23	6.35	0.250	30.2	1.189	27.50	1.083	42	1.654

**CODICI ORDINAZIONE  
ORDER CODES**

<b>1SP</b>		
CODICI COMPLETI POMPA SINGOLA - GRUPPO 1 COMPLETE ORDER CODE SINGLE PUMP - GROUP 1		
CODICE CODE	SIGLA DI ORDINAZIONE COMPLETA COMPLETE ORDER CODE	DESCRIZIONE DESCRIPTION
<b>1GP10010000</b>	1SP-A-090-D-EUR-B-N-10-0-G	Flangia Europea - cilindrata 0.89 cm <sup>3</sup> /giro - connessione GAS European flange - displacement 0.05 in <sup>3</sup> /rev - connection GAS
<b>1GP10010028</b>	1SP-A-012-D-EUR-B-N-10-0-G	Flangia Europea - cilindrata 1.18 cm <sup>3</sup> /giro - connessione GAS European flange - displacement 0.07 in <sup>3</sup> /rev - connection GAS
<b>1GP10010032</b>	1SP-A-012-D-EUR-B-N-10-0-N	Flangia Europea - cilindrata 1.18 cm <sup>3</sup> /giro - connessione UNF European flange - displacement 0.07 in <sup>3</sup> /rev - connection UNF
<b>1GP10010066</b>	1SP-A-016-D-EUR-B-N-10-0-N	Flangia Europea - cilindrata 1.6 cm <sup>3</sup> /giro - connessione UNF European flange - displacement 0.10 in <sup>3</sup> /rev - connection UNF
<b>1GP10010088</b>	1SP-A-020-D-EUR-B-N-10-0-G	Flangia Europea - cilindrata 2.0 cm <sup>3</sup> /giro - connessione GAS European flange - displacement 0.12 in <sup>3</sup> /rev - connection GAS
<b>1GP10010090</b>	1SP-A-020-D-EUR-B-N-10-0-N	Flangia Europea - cilindrata 2.0 cm <sup>3</sup> /giro - connessione UNF European flange - displacement 0.12 in <sup>3</sup> /rev - connection UNF
<b>1GP10010126</b>	1SP-A-025-D-EUR-B-N-10-0-G	Flangia Europea - cilindrata 2.5 cm <sup>3</sup> /giro - connessione GAS European flange - displacement 0.15 in <sup>3</sup> /rev - connection GAS
<b>1GP10010129</b>	1SP-A-025-D-EUR-B-N-10-0-N	Flangia Europea - cilindrata 2.5 cm <sup>3</sup> /giro - connessione UNF European flange - displacement 0.15 in <sup>3</sup> /rev - connection UNF
<b>1GP10010163</b>	1SP-A-032-D-EUR-B-N-10-0-G	Flangia Europea - cilindrata 3.2 cm <sup>3</sup> /giro - connessione GAS European flange - displacement 0.20 in <sup>3</sup> /rev - connection GAS
<b>1GP10010167</b>	1SP-A-032-D-EUR-B-N-10-0-N	Flangia Europea - cilindrata 3.2 cm <sup>3</sup> /giro - connessione UNF European flange - displacement 0.20 in <sup>3</sup> /rev - connection UNF
<b>1GP10010204</b>	1SP-A-032-S-MC32-B-N-27-5-G	Flangia per minicentralina - cilindrata 3.2 cm <sup>3</sup> /giro - connessione GAS Power-pack Flange - displacement 0.20 in <sup>3</sup> /rev - connection GAS
<b>1GP10010211</b>	1SP-A-037-D-EUR-B-N-10-0-G	Flangia Europea - cilindrata 3.7 cm <sup>3</sup> /giro - connessione GAS European flange - displacement 0.23 in <sup>3</sup> /rev - connection GAS
<b>1GP10010241</b>	1SP-A-042-D-EUR-B-N-10-0-G	Flangia Europea - cilindrata 4.2 cm <sup>3</sup> /giro - connessione GAS European flange - displacement 0.26 in <sup>3</sup> /rev - connection GAS
<b>1GP10010243</b>	1SP-A-042-D-EUR-B-N-10-0-N	Flangia Europea - cilindrata 4.2 cm <sup>3</sup> /giro - connessione UNF European flange - displacement 0.26 in <sup>3</sup> /rev - connection UNF
<b>1GP10010275</b>	1SP-A-050-D-EUR-B-N-10-0-G	Flangia Europea - cilindrata 5.0 cm <sup>3</sup> /giro - connessione GAS European flange - displacement 0.31 in <sup>3</sup> /rev - connection GAS
<b>1GP10010278</b>	1SP-A-050-D-EUR-B-N-10-0-N	Flangia Europea - cilindrata 5.0 cm <sup>3</sup> /giro - connessione UNF European flange - displacement 0.31 in <sup>3</sup> /rev - connection UNF
<b>1GP10010312</b>	1SP-A-063-D-EUR-B-N-10-0-G	Flangia Europea - cilindrata 6.3 cm <sup>3</sup> /giro - connessione GAS European flange - displacement 0.38 in <sup>3</sup> /rev - connection GAS
<b>1GP10010316</b>	1SP-A-063-D-EUR-B-N-10-0-N	Flangia Europea - cilindrata 6.3 cm <sup>3</sup> /giro - connessione UNF European flange - displacement 0.38 in <sup>3</sup> /rev - connection UNF
<b>1GP10010320</b>	1SP-A-063-D-EUR-B-N-14-0-N	Flangia Europea - cilindrata 6.3 cm <sup>3</sup> /giro - albero 14 - connessione UNF European flange - displacement 0.38 in <sup>3</sup> /rev - shaft 14 - connection UNF
<b>1GP10010374</b>	1SP-A-078-S-MC32-B-N-27-5-G	Flangia per minicentralina - cilindrata 7.76 cm <sup>3</sup> /giro - connessione GAS Power-pack flange - displacement 0.47 in <sup>3</sup> /rev - connection GAS

**CODICI ORDINAZIONE**  
**ORDER CODES**

CODICI COMPLETI POMPA SINGOLA - GRUPPO 2 COMPLETE ORDER CODE SINGLE PUMP - GROUP 2		
2SP		
CODICE CODE	SIGLA DI ORDINAZIONE COMPLETA COMPLETE ORDER CODE	DESCRIZIONE DESCRIPTION
<b>1GP20010000</b>	2SP-A-040-D-EUR-B-N-10-0-G	Flangia Europea - cilindrata 4.0 cm <sup>3</sup> /giro - connessione GAS <i>European flange - displacement 0.24 in<sup>3</sup>/rev - connection GAS</i>
<b>1GP20010005</b>	2SP-A-040-D-EUR-B-N-10-0-N	Flangia Europea - cilindrata 4.0 cm <sup>3</sup> /giro - connessione UNF <i>European flange - displacement 0.24 in<sup>3</sup>/rev - connection UNF</i>
<b>1GP20010075</b>	2SP-A-060-D-EUR-B-N-10-0-G	Flangia Europea - cilindrata 6.0 cm <sup>3</sup> /giro - connessione GAS <i>European flange - displacement 0.37 in<sup>3</sup>/rev - connection GAS</i>
<b>1GP20010081</b>	2SP-A-060-D-EUR-B-N-10-0-N	Flangia Europea - cilindrata 6.0 cm <sup>3</sup> /giro - connessione UNF <i>European flange - displacement 0.37 in<sup>3</sup>/rev - connection UNF</i>
<b>1GP20010172</b>	2SP-A-080-D-EUR-B-N-10-0-G	Flangia Europea - cilindrata 8.5 cm <sup>3</sup> /giro - connessione GAS <i>European flange - displacement 0.52 in<sup>3</sup>/rev - connection GAS</i>
<b>1GP20010179</b>	2SP-A-080-D-EUR-B-N-10-0-N	Flangia Europea - cilindrata 8.5 cm <sup>3</sup> /giro - connessione UNF <i>European flange - displacement 0.52 in<sup>3</sup>/rev - connection UNF</i>
<b>1GP20010299</b>	2SP-A-110-D-EUR-B-N-10-0-G	Flangia Europea - cilindrata 11 cm <sup>3</sup> /giro - connessione GAS <i>European flange - displacement 0.67 in<sup>3</sup>/rev - connection GAS</i>
<b>1GP20010307</b>	2SP-A-110-D-EUR-B-N-10-0-N	Flangia Europea - cilindrata 11 cm <sup>3</sup> /giro - connessione UNF (destra) <i>European flange - displacement 0.67 in<sup>3</sup>/rev - connection UNF (right)</i>
<b>1GP20010375</b>	2SP-A-110-D-SAEA-B-N-14-0-N	Flangia SAEA - cilindrata 11 cm <sup>3</sup> /giro - albero 14 - connessione UNF <i>SAEA flange - displacement 0.67 in<sup>3</sup>/rev - shaft 14 - connection UNF</i>
<b>1GP20010396</b>	2SP-A-110-S-EUR-B-N-10-0-N	Flangia Europea - cilindrata 11 cm <sup>3</sup> /giro - connessione UNF (sinistra) <i>European flange - displacement 0.67 in<sup>3</sup>/rev - connection UNF (left)</i>
<b>1GP20010447</b>	2SP-A-140-D-EUR-B-N-10-0-G	Flangia Europea - cilindrata 14 cm <sup>3</sup> /giro - connessione GAS <i>European flange - displacement 0.85 in<sup>3</sup>/rev - connection GAS</i>
<b>1GP20010454</b>	2SP-A-140-D-EUR-B-N-10-0-N	Flangia Europea - cilindrata 14 cm <sup>3</sup> /giro - connessione UNF <i>European flange - displacement 0.85 in<sup>3</sup>/rev - connection UNF</i>
<b>1GP20010515</b>	2SP-A-140-D-SAEA-B-N-14-0-N	Flangia SAEA - cilindrata 14 cm <sup>3</sup> /giro - albero 14 - connessione UNF <i>SAEA flange - displacement 0.85 in<sup>3</sup>/rev - shaft 14 - connection UNF</i>
<b>1GP20010572</b>	2SP-A-160-D-EUR-B-N-10-0-G	Flangia Europea - cilindrata 16.5 cm <sup>3</sup> /giro - connessione GAS <i>European flange - displacement 1.01 in<sup>3</sup>/rev - connection GAS</i>
<b>1GP20010579</b>	2SP-A-160-D-EUR-B-N-10-0-N	Flangia Europea - cilindrata 16.5 cm <sup>3</sup> /giro - connessione UNF (destra) <i>European flange - displacement 1.01 in<sup>3</sup>/rev - connection UNF (right)</i>
<b>1GP20010637</b>	2SP-A-160-D-SAEA-B-N-14-0-N	Flangia SAEA - cilindrata 16.5 cm <sup>3</sup> /giro - albero 14 - connessione UNF <i>SAEA flange - displacement 1.01 in<sup>3</sup>/rev - shaft 14 - connection UNF</i>
<b>1GP20010657</b>	2SP-A-160-S-EUR-B-N-10-0-N	Flangia Europea - cilindrata 16.5 cm <sup>3</sup> /giro - connessione UNF (sinistra) <i>European flange - displacement 1.01 in<sup>3</sup>/rev - connection UNF (left)</i>
<b>1GP20010706</b>	2SP-A-190-D-EUR-B-N-10-0-G	Flangia Europea - cilindrata 19.5 cm <sup>3</sup> /giro - connessione GAS <i>European flange - displacement 1.19 in<sup>3</sup>/rev - connection GAS</i>
<b>1GP20010715</b>	2SP-A-190-D-EUR-B-N-10-0-N	Flangia Europea - cilindrata 19.5 cm <sup>3</sup> /giro - connessione UNF <i>European flange - displacement 1.19 in<sup>3</sup>/rev - connection UNF</i>
<b>1GP20010814</b>	2SP-A-220-D-EUR-B-N-10-0-G	Flangia Europea - cilindrata 22.5 cm <sup>3</sup> /giro - connessione GAS <i>European flange - displacement 1.37 in<sup>3</sup>/rev - connection GAS</i>
<b>1GP20010821</b>	2SP-A-220-D-EUR-B-N-10-0-N	Flangia Europea - cilindrata 22.5 cm <sup>3</sup> /giro - connessione UNF <i>European flange - displacement 1.37 in<sup>3</sup>/rev - connection UNF</i>
<b>1GP20010921</b>	2SP-A-260-D-EUR-B-N-10-0-G	Flangia Europea - cilindrata 26 cm <sup>3</sup> /giro - connessione GAS <i>European flange - displacement 1.59 in<sup>3</sup>/rev - connection GAS</i>
<b>1GP20010929</b>	2SP-A-260-D-EUR-B-N-10-0-N	Flangia Europea - cilindrata 26 cm <sup>3</sup> /giro - connessione UNF <i>European flange - displacement 1.59 in<sup>3</sup>/rev - connection UNF</i>

**CODICI ORDINAZIONE  
ORDER CODES**

CODICI COMPLETI POMPA SINGOLA - GRUPPO 3 COMPLETE ORDER CODE SINGLE PUMP - GROUP 3		
3GP		
CODICE CODE	SIGLA DI ORDINAZIONE COMPLETA COMPLETE ORDER CODE	DESCRIZIONE DESCRIPTION
<b>1GP30010066</b>	3GP-G-230-D-EUR-B-N-10-0-N	Flangia Europea - cilindrata 23 cm <sup>3</sup> /giro - connessione UNF <i>European flange - displacement 1.4 in<sup>3</sup>/rev - connection UNF</i>
<b>1GP30010116</b>	3GP-G-300-D-EUR-B-N-10-0-G	Flangia Europea - cilindrata 30.2 cm <sup>3</sup> /giro - connessione GAS <i>European flange - displacement 1.8 in<sup>3</sup>/rev - connection GAS</i>
<b>1GP30010117</b>	3GP-G-300-D-EUR-B-N-10-0-N	Flangia Europea - cilindrata 30.2 cm <sup>3</sup> /giro - connessione UNF <i>European flange - displacement 1.8 in<sup>3</sup>/rev - connection UNF</i>
<b>1GP30010178</b>	3GP-G-340-D-EUR-B-N-10-0-G	Flangia Europea - cilindrata 33.8 cm <sup>3</sup> /giro - connessione GAS <i>European flange - displacement 2.1 in<sup>3</sup>/rev - connection GAS</i>
<b>1GP30010179</b>	3GP-G-340-D-EUR-B-N-10-0-N	Flangia Europea - cilindrata 33.8 cm <sup>3</sup> /giro - connessione UNF <i>European flange - displacement 2.1 in<sup>3</sup>/rev - connection UNF</i>
<b>1GP30010234</b>	3GP-G-370-D-EUR-B-N-10-0-G	Flangia Europea - cilindrata 37.5 cm <sup>3</sup> /giro - connessione GAS <i>European flange - displacement 2.3 in<sup>3</sup>/rev - connection GAS</i>
<b>1GP30010235</b>	3GP-G-370-D-EUR-B-N-10-0-N	Flangia Europea - cilindrata 37.5 cm <sup>3</sup> /giro - connessione UNF <i>European flange - displacement 2.3 in<sup>3</sup>/rev - connection UNF</i>
<b>1GP30010244</b>	3GP-G-440-D-EUR-B-N-10-0-G	Flangia Europea - cilindrata 44.6 cm <sup>3</sup> /giro - connessione GAS <i>European flange - displacement 2.7 in<sup>3</sup>/rev - connection GAS</i>
<b>1GP30010245</b>	3GP-G-440-D-EUR-B-N-10-0-N	Flangia Europea - cilindrata 44.6 cm <sup>3</sup> /giro - connessione UNF <i>European flange - displacement 2.7 in<sup>3</sup>/rev - connection UNF</i>
<b>1GP30010349</b>	3GP-G-530-D-EUR-B-N-10-0-G	Flangia Europea - cilindrata 53 cm <sup>3</sup> /giro - connessione GAS <i>European flange - displacement 3.2 in<sup>3</sup>/rev - connection GAS</i>
<b>1GP30010351</b>	3GP-G-530-D-EUR-B-N-10-0-N	Flangia Europea - cilindrata 53 cm <sup>3</sup> /giro - connessione UNF <i>European flange - displacement 3.2 in<sup>3</sup>/rev - connection UNF</i>
<b>1GP30010359</b>	3GP-G-620-D-EUR-B-N-10-0-N	Flangia Europea - cilindrata 62.7 cm <sup>3</sup> /giro - connessione UNF <i>European flange - displacement 3.8 in<sup>3</sup>/rev - connection UNF</i>
<b>1GP30010408</b>	3GP-G-700-D-EUR-B-N-10-0-N	Flangia Europea - cilindrata 70.5 cm <sup>3</sup> /giro - connessione UNF <i>European flange - displacement 4.3 in<sup>3</sup>/rev - connection UNF</i>
<b>1GP30010413</b>	3GP-G-770-D-EUR-B-N-10-0-N	Flangia Europea - cilindrata 77.2 cm <sup>3</sup> /giro - connessione UNF <i>European flange - displacement 4.7 in<sup>3</sup>/rev - connection UNF</i>

**CODICI ORDINAZIONE**  
**ORDER CODES**

CODICI COMPLETI MOTORE - GRUPPO 2 COMPLETE ORDER CODE MOTOR - GROUP 2		
2SM		
CODICE CODE	SIGLA DI ORDINAZIONE COMPLETA COMPLETE ORDER CODE	DESCRIZIONE DESCRIPTION
<b>1GM20010126</b>	2SM-A-110-R-EUR-B-N-10-0-G	Flangia europea - cilindrata 11 cm <sup>3</sup> /giro - connessione GAS (reversibile) <i>European flange - displacement 0.67 in<sup>3</sup>/rev - connection GAS (reversible)</i>
<b>1GM20010128</b>	2SM-A-110-R-EUR-H-N-10-0-N	Flangia europea - cilindrata 11 cm <sup>3</sup> /giro - connessione UNF (reversibile) <i>European flange - displacement 0.67 in<sup>3</sup>/rev - connection UNF (reversible)</i>
<b>1GM20010180</b>	2SM-A-140-R-EUR-H-N-10-0-G	Flangia europea - cilindrata 14 cm <sup>3</sup> /giro - connessione GAS (reversibile) <i>European flange - displacement 0.85 in<sup>3</sup>/rev - connection GAS (reversible)</i>
<b>1GM20010181</b>	2SM-A-140-R-EUR-H-N-10-0-N	Flangia europea - cilindrata 14 cm <sup>3</sup> /giro - connessione UNF (reversibile) <i>European flange - displacement 0.85 in<sup>3</sup>/rev - connection UNF (reversible)</i>
<b>1GM20010223</b>	2SM-A-160-R-EUR-H-N-10-0-G	Flangia europea - cilindrata 16.5 cm <sup>3</sup> /giro - connessione GAS (reversibile) <i>European flange - displacement 1.01 in<sup>3</sup>/rev - connection GAS (reversible)</i>
<b>1GM20010225</b>	2SM-A-160-R-EUR-H-N-10-0-N	Flangia europea - cilindrata 16.5 cm <sup>3</sup> /giro - connessione UNF (reversibile) <i>European flange - displacement 1.01 in<sup>3</sup>/rev - connection UNF (reversible)</i>
<b>1GM20010269</b>	2SM-A-190-R-EUR-H-N-10-0-G	Flangia europea - cilindrata 19.5 cm <sup>3</sup> /giro - connessione GAS (reversibile) <i>European flange - displacement 1.19 in<sup>3</sup>/rev - connection GAS (reversible)</i>
<b>1GM20010271</b>	2SM-A-190-R-EUR-H-N-10-0-N	Flangia europea - cilindrata 19.5 cm <sup>3</sup> /giro - connessione UNF (reversibile) <i>European flange - displacement 1.19 in<sup>3</sup>/rev - connection UNF (reversible)</i>







Innovation · Continuity · Integration  
————— It is Power —————

 **walvoil**  
FLUID POWER E|MOTION

 **walvoil**

 **hydro control**

 **Galtech**  
technology

D1WGEM01IE  
6<sup>th</sup> Edition November 2018

Walvoil S.P.A. • 42124 Reggio Emilia • Italy • Via Adige, 13/D • Tel. +39.0522.932411 • Fax +39.0522.300984  
[www.walvoil.com](http://www.walvoil.com)

